

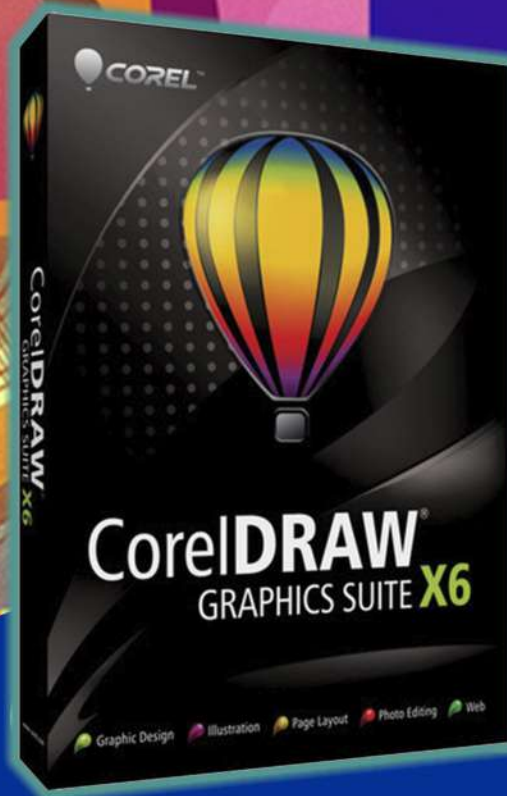

RGYCSM
ISO 9001 : 2015 ORG

There's
a book
just right
for you.



CorelDRAW

GRAPHICS SUITE X6

www.rgycsm.org

December, 2020





CorelDRAW[®] GRAPHICS SUITE **X6**

GUIDEBOOK

Copyright © 2012 Corel Corporation. All rights reserved.

CorelDRAW® Graphics Suite X6 Guidebook

Product specifications, pricing, packaging, technical support and information (“specifications”) refer to the retail English version only. The specifications for all other versions (including other language versions) may vary.

Information is provided by Corel on an "as is" basis, without any other warranties or conditions, express or implied, including, but not limited to, warranties of merchantable quality, satisfactory quality, merchantability or fitness for a particular purpose, or those arising by law, statute, usage of trade, course of dealing or otherwise. The entire risk as to the results of the information provided or its use is assumed by you. Corel shall have no liability to you or any other person or entity for any indirect, incidental, special, or consequential damages whatsoever, including, but not limited to, loss of revenue or profit, lost or damaged data or other commercial or economic loss, even if Corel has been advised of the possibility of such damages, or they are foreseeable. Corel is also not liable for any claims made by any third party. Corel's maximum aggregate liability to you shall not exceed the costs paid by you to purchase the materials. Some states/countries do not allow exclusions or limitations of liability for consequential or incidental damages, so the above limitations may not apply to you.

Corel, the Corel logo, the Corel balloon, Corel CAPTURE, Corel CONNECT, Corel DESIGNER, Corel Digital Studio, CorelDRAW, Corel PHOTO-PAINT, Corel VideoStudio, Corel WinDVD, Painter, PaintShop Pro, PowerClip, PowerTRACE, Smart Carver, WinZip, and WordPerfect are trademarks or registered trademarks of Corel Corporation and/or its subsidiaries in Canada, the U.S., and/or other countries. Other product, font, and company names and logos may be trademarks or registered trademarks of their respective companies.

All images included in this publication are attributed to the artists who created them. Some images may have been cropped and/or resized, backgrounds may have been added, and images may have been combined with other images on the same page. In the Gallery section, the artists' names have been added to the images, and image elements that contain brand names and logos have been removed.

116011

Contents

Part One: Introduction

Chapter 1: Welcome	3
Chapter 2: Installation and Support	11
Chapter 3: What's New	15

Part Two: Getting Started

Chapter 4: CorelDRAW Basics	27
Chapter 5: Corel PHOTO-PAINT Basics	47

Part Three: Color, Type, and Styles

Chapter 6: Color Basics	71
Chapter 7: Color Management	89
Chapter 8: Working with Text	105
Chapter 9: Styles and Style Sets	117



Part Four: Guide to Digital Content

Chapter 10: Finding and Managing Content	129
Chapter 11: Content Types	135
Chapter 12: Templates	157

Part Five: Tips and Techniques

Chapter 13: Sign Making	167
Chapter 14: Illustration	181
Chapter 15: Page Layout	199

Part Six: Insights from the Experts

Chapter 16: Design of a Soccer Club Logo	221
Chapter 17: The Story of a Reader Chair	235
Chapter 18: Concept Art	251





Image created by
Joseph Diaz
USA

Part One

Introduction





Chapter 1: Welcome

What's included in
CorelDRAW Graphics Suite X6 **4**

About this guidebook **4**

Guidebook conventions **5**

Other learning resources **6**



Chapter 1: Welcome

Welcome to CorelDRAW® Graphics Suite X6, a comprehensive software solution for graphic design, page layout, and photo editing.

What's included in CorelDRAW Graphics Suite X6

CorelDRAW Graphics Suite X6 includes the following applications:

- CorelDRAW®
- Corel® PHOTO-PAINT™
- Corel CAPTURE™
- Corel® CONNECT™
- Bitstream® Font Navigator®

CorelDRAW

CorelDRAW is an intuitive and versatile graphics application for creating high-quality vector illustrations, logo designs, and page layouts.

Corel PHOTO-PAINT

Corel PHOTO-PAINT is a complete image-editing application that lets you retouch and enhance photos as well as create original bitmap illustrations and paintings. You can easily correct red-eye or exposure problems, retouch RAW camera files, and prepare images for the Web.

Corel CAPTURE

Corel CAPTURE is an easy-to-use application for capturing images from your computer screen.

Corel CONNECT

Corel CONNECT is an application that provides easy access to content such as clipart, photos, fonts, and more.

Bitstream Font Navigator

Bitstream Font Navigator is an application for browsing, organizing, and managing fonts.

About this guidebook

This guidebook is designed to enrich your experience of working with CorelDRAW and Corel PHOTO-PAINT and to inspire you to do more than you ever thought possible.

Individual chapters introduce you to the workspace of each application and provide tips and techniques that can help you, regardless of your skill level.

This guidebook is divided into seven parts.

Part One: Introduction

Chapters 1 through 3 describe the new features of CorelDRAW Graphics Suite X6 as well as the learning resources that are available online and within each application.

Part Two: Getting Started

Chapters 4 and 5 present basic information about CorelDRAW and Corel PHOTO-PAINT,



including workspace tours that describe the main tools in each application.

Part Three: Color, Type, and Styles

Chapters 6 through 9 provide a review of fundamental color concepts and show you how to work with color and text as well as format objects by using styles and style sets.

Part Four: Guide to Digital Content

Chapters 10 through 12 provide information about working with Corel CONNECT and introduce the available content, such as clipart, photos, and fonts.

Part Five: Tips and Techniques

Chapters 13 through 15 give you useful tips about the specific workflows for sign making, illustration, and page layout.

Part Six: Insights from the Experts

Chapters 16 through 18 present tutorials by graphic design professionals from diverse industries who use CorelDRAW Graphics Suite in their everyday work. In these chapters, the authors share how the software helps them express their creativity and artistic freedom as they create a sports team logo, furniture design, and concept painting.

 To access the tutorials as individual PDFs, click **Help ▶ Insights from the experts**.

Part Seven: Gallery

A stunning collection of artwork, created in CorelDRAW Graphics Suite by professional designers and illustrators, is included in this last part of the guidebook.

 To access this guidebook in PDF format, click **Help ▶ Guidebook**.

Guidebook conventions

The following conventions make it easy to locate information in the guidebook.

References to the application interface

References to elements of the application interface, such as menu commands, are indicated by bold formatting. For example, “Click **File ▶ Open**” refers to clicking **File** on the menu bar and then clicking the **Open** command.

Tips

The guidebook contains brief tips, which may highlight portions of your workflow, offer creative ideas that you can try out, or provide information about performing a task. These tips are indented and marked by a special icon  for easy reference.

Color-coded pages

Each part of the guidebook is coded for easy reference with a distinctive band of color in the upper-left or upper-right area of the page.

Cross-references

If you want to learn more about a specific subject, you can use the cross-references. Two types of cross-references are used in this guidebook:

- cross-references to the Help in an application
- cross-references to a specific page in the Guidebook

If a cross-reference points to the Help, you can access the information by starting the specific

application, clicking **Help ► Help topics**, and then browsing or searching for the relevant topic.

Other learning resources

In addition to this guidebook, various other learning resources can help you get started with CoreDRAW Graphics Suite X6. For example, you can use the Help to learn about basic tools and techniques, visit the **CoreDRAW.com** community to ask questions and receive help and suggestions from other users, or watch video tutorials to see graphic design in action.

Help

The Help is accessible from within the application and provides comprehensive information about product features. You can browse through a list of topics, look up tools and topics in the index, or search for specific words.

 To access the Help, click **Help ► Help topics**. The application displays the Web-based Help if an Internet connection is available, or local Help if there is no Internet connection.

Tooltips

Tooltips provide helpful information about application controls when you position the pointer over icons, buttons, and other interface elements.

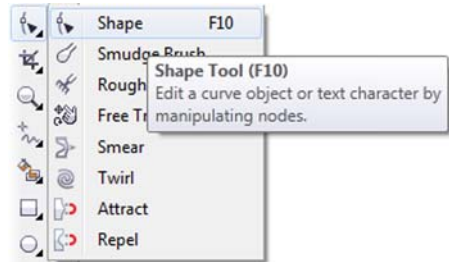

Example of a tooltip

Hints

Hints provide instant information about tools in the toolbox. When you click a tool, a hint appears, telling you how to use the tool. Hints are displayed by default in the **Hints** docker on the right side of the application window, but you can hide them when you no longer need them.

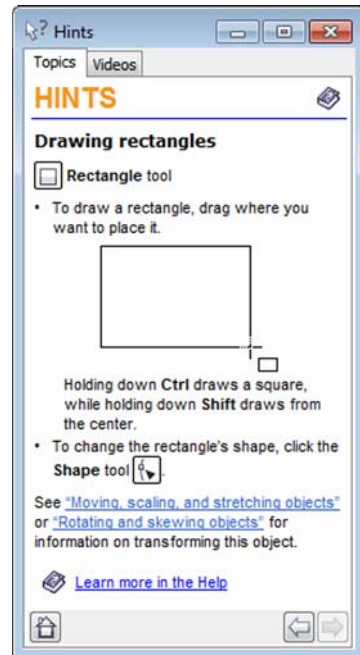

Hints docker in CoreDRAW

 To display or hide Hints, click **Help ▶ Hints**.

To find additional information about a tool, you can access a relevant Help topic by clicking the **Help** button  in the upper-right corner of the **Hints** docker.

Welcome screen

The Welcome screen gives you easy access to resources in the applications and lets you quickly complete common tasks, such as opening files and starting files from templates. You can also find out about the new features in CorelDRAW Graphics Suite X6 and get inspired by graphic designs that are featured on the Gallery pages. In addition, you can find tutorials and tips, and get the latest product updates.

 You can access the Welcome screen by clicking **Help ▶ Welcome screen**.

Videos

Short videos are available to show you how to complete basic tasks such as drawing, shaping, and coloring objects in CorelDRAW, or masking and cropping in Corel PHOTO-PAINT. In addition, longer video tutorials introduce you to the working environment of CorelDRAW and Corel PHOTO-PAINT and guide you through specific tasks and techniques.

 To access the short videos, click the **Videos** tab in the **Hints** docker.

To access the video tutorials, click **Help ▶ Video tutorials**.

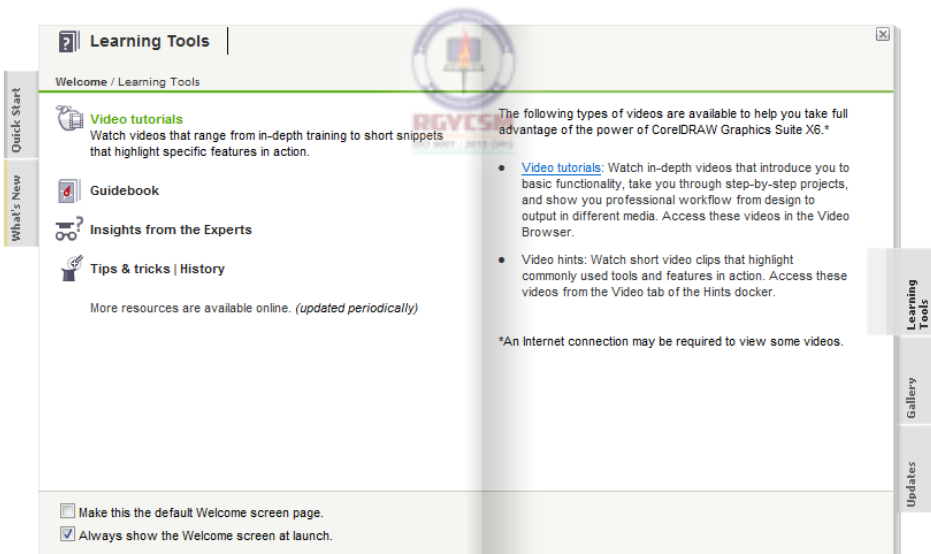

Welcome screen in CorelDRAW

Web-based resources

The following resources are available on the Corel Web site (www.corel.com) to help you get the most out of CorelDRAW Graphics Suite X6:

- **Corel Knowledge Base** — The articles in this searchable database were written by members of the Corel Technical Support team in response to questions by users of CorelDRAW Graphics Suite.
- **CorelDRAW.com community** — In this online environment, you can share your experience with the product, ask questions, and receive help and suggestions from other users.
- **Tips and tricks** — This valuable information is provided by the Corel Documentation team to help you take full advantage of product features.
- **Tutorials** — In-depth tutorials let you share the knowledge and techniques of CorelDRAW Graphics Suite experts.
- **Third-party resources** — For additional information about the tools in the suite, you can access third-party print and online resources that cover various areas of graphic design.

Macro programming guide

The *CorelDRAW Graphics Suite X6 Macro Programming Guide* provides a streamlined instructional approach to programming macros for CorelDRAW Graphics Suite X6. By creating macros with CorelDRAW and Corel PHOTO-PAINT, you can automate tasks and provide customized solutions. You can use either Microsoft® Visual Basic for Applications (VBA) or Microsoft® Visual Studio® Tools for Applications (VSTA) to create macros.

 If your installation of CorelDRAW Graphics Suite X6 includes VBA or VSTA, you can access the macro programming guide by clicking **Start ▶ All programs ▶ CorelDRAW Graphics Suite X6 ▶ Documentation**.

Network deployment guide

The *CorelDRAW Graphics Suite X6 Deployment Guide* is a step-by-step resource for deploying CorelDRAW Graphics Suite X6 to a network. This guide is provided to customers who purchase a volume (“multi-seat”) license of CorelDRAW Graphics Suite X6 for their organizations.

 To purchase a volume license of CorelDRAW Graphics Suite X6 and obtain the *CorelDRAW Graphics Suite X6 Deployment Guide*, contact Corel Support Services (www.corel.com/support).

Customized training and integration resources

Corel Corporation has training partnerships with other firms and provides resources for developers and consultants.

Corel customized training

Corel Training Specialists can provide you with customized training, tailored to your work environment, to help you get the most out of the Corel software that you have installed. These experts can help you develop a curriculum that is practical and relevant to the needs of your organization. For more information, visit www.corel.com/customizedtraining.

Corel Training Partners

A Corel Training Partner (CTP) is an independent, officially accredited local organization that provides training and training resources for Corel products. CTPs are located worldwide for your convenience. To find a partner near you, visit www.corel.com.

Corel Technology Partners

Corel Technology Partners are businesses that embed Corel technology within their products, develop plug-in applications for Corel software, or integrate standalone applications into Corel technology solutions. This comprehensive program is designed especially for developers and consultants, and it includes the necessary components for designing, developing, testing, and marketing custom solutions that are related to Corel products.

For more information about Corel Technology Partners, please e-mail Corel Corporation at techpartner@corel.com.







Chapter 2: Installation and Support

Installing CorelDRAW Graphics Suite applications **12**

Changing languages **12**

Updating Corel products **12**

Corel Support Services **13**

About Corel Corporation **13**

Chapter 2: Installation and Support

CoreDRAW Graphics Suite X6 is easy to install, register, and customize.

Installing CoreDRAW Graphics Suite applications

The installation wizard makes it easy to install CoreDRAW Graphics Suite applications and components. You can install the applications with the default settings, or you can customize the installation by choosing different options.

When you insert the installation disc in the DVD drive, the installation wizard starts automatically. Follow the instructions on the screen to complete the installation.

 (Windows® 7 and Windows Vista®) If the installation wizard does not start automatically, click **Start** on the Windows taskbar, and type **X:\autorun.exe** in the search box, where **X** is the letter that corresponds to the DVD drive.

(Windows® XP) If the installation wizard does not start automatically, click **Start** on the Windows taskbar, and click **Run**. Type **X:\autorun.exe**, where **X** is the letter that corresponds to the DVD drive.

After you install the applications, you can also use the installation wizard to do the following:

- add and delete components in the current installation
- repair the current installation by reinstalling all application features
- uninstall CoreDRAW Graphics Suite

 Before repairing an installation, try resetting the current workspace to the default settings by holding down **F8** while starting the application.

For more information, see “Installing CoreDRAW Graphics Suite applications” in the Help.

Changing languages

If an application has been installed in more than one language, you can change the language of the user interface and Help at any time.

 To change the language of the application, click **Tools ▶ Options**. In the list of categories, click **Global**, and choose a language from the **Select the language for the user interface** list box. Restart the application to apply the new language settings.

If you did not install a specific language when you first installed the product, you can do so later. For more information, see “Changing languages” in the Help.

Updating Corel products

During product installation, you can choose the option to download product updates.

 To check for product updates at any time, click **Help ▶ Updates**.

Corel Support Services

Corel Support Services can provide you with prompt and accurate information about product features, specifications, pricing, availability, services, and technical support.

For the most current information on support services available for your Corel product, visit **www.corel.com/support**.

About Corel Corporation

Corel is one of the world's top software companies, with more than 100 million active users in over 75 countries. We develop software that helps people express their ideas and share their stories in more exciting, creative, and persuasive ways. Through the years, we've built a reputation for delivering innovative, trusted products that are easy to learn and use, helping people achieve new levels of productivity. The industry has responded with hundreds of awards for software innovation, design, and value.



Our award-winning product portfolio includes some of the world's most widely recognized and popular software brands, including CorelDRAW® Graphics Suite, Corel® Painter™, Corel DESIGNER® Technical Suite, Corel® PaintShop™ Pro, Corel® VideoStudio®, Corel® WinDVD®, Corel® WordPerfect® Office, and WinZip®. Our global headquarters are in Ottawa, Canada, with major offices in the United States, United Kingdom, Germany, China, Taiwan, and Japan.



Chapter 3: What's New

Work faster and more efficiently **16**

Create layouts with ease **19**

Design with style and creativity **22**



Chapter 3: What's New

The new and enhanced features of CorelDRAW Graphics Suite can help you express your creative ideas compellingly.

 To access the list of new features from the application, click **Help ▶ What's new**.

To learn what was new in previous versions of CorelDRAW Graphics Suite, click **Help ▶ Highlight what's new**, and choose a version. Menu commands and tools for features introduced or improved in that version are highlighted.

Work faster and more efficiently

From organizing project assets and accessing the suite's vast collection of content, to quickly identifying available formatting options and removing unwanted areas in photos, CorelDRAW Graphics Suite X6 offers several workflow innovations that help you be more efficient and productive.

Multiple trays in Corel CONNECT *(New!)*

Corel CONNECT now lets you work with several trays at the same time, which gives you increased flexibility in organizing assets for multiple projects. Trays help you gather content from various folders or online sources, and are shared among CorelDRAW, Corel PHOTO-PAINT, and Corel CONNECT.

You can use and maintain separate trays for different types of content. For example, you might be working on a project that requires

photos, vector graphics, and bitmap icons. Keeping these types of content in separate trays provides a way to find assets quickly and easily. As an added convenience, you can open files from the tray to get a full-size preview. You can also rename trays or change the default folder to which trays are saved.



Multiple trays help you find assets quickly and easily.

Search capability in Corel CONNECT

(New!)

The new Corel CONNECT search toolbar lets you instantly extract images from a web site. Simply type a web address in the **Search and address** box, and Corel CONNECT immediately gathers all images defined with an HTML `` tag from the Web site, making it quick and easy to leverage content assets from online sources. You can also type search terms or a folder path to have Corel CONNECT search your computer, network, or other online resources for content.

Content *(New and enhanced!)*

The improved Corel CONNECT provides quick access to all CorelDRAW Graphics Suite X6

content, while also helping you acquire additional content from online vendors.



Corel CONNECT lets you access a wealth of content.

The suite's content library includes:

- 10,000 high quality clipart and digital images
- 1,000 professional, high-resolution digital photos
- 1,000 OpenType® fonts, including premium fonts such as Helvetica®
- 350 professionally designed templates
- 2,000 vehicle templates
- 800 frames and patterns, and more.

Object Properties docker *(New!)*

In CorelDRAW X6, the redesigned **Object properties** docker now presents only object-dependent formatting options and properties. By grouping all object settings in one location, this docker helps you fine-tune your designs faster than ever before.

For example, if you create a rectangle, the **Object properties** docker automatically presents outline, fill, and corner formatting

options, as well as the rectangle's properties. If you create a text frame, the docker instantly displays character, paragraph, and frame formatting options, as well as the text frame's properties.

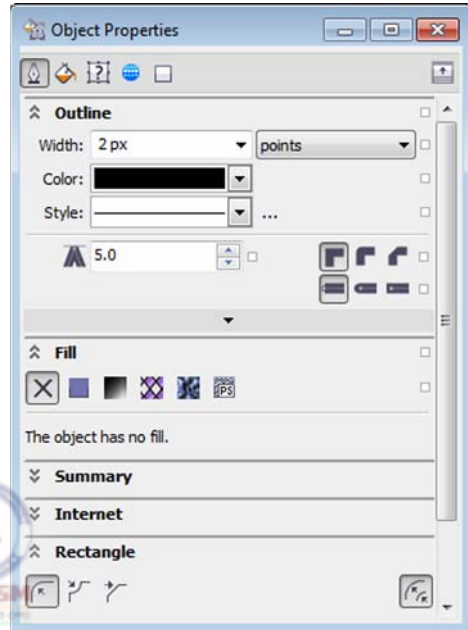

*The redesigned **Object properties** docker groups all object settings in one location.*

Smart Carver *(New!)*

In Corel PHOTO-PAINT X6, the new Smart Carver™ tool makes it easy to remove unwanted areas from a photo and simultaneously adjust the photo's aspect ratio. For example, you might want to define an area of a photo that you would like to keep or remove, such as a person in the photo. The versatile **Object removal** brush lets you choose to paint either the area of the photo that you want to preserve or the area that you want to remove.

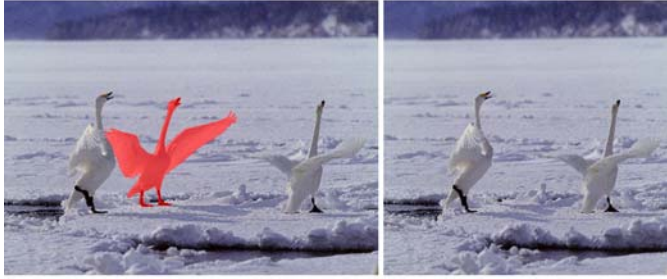

The Smart Carver makes it easy to remove unwanted areas and adjust the photo's aspect ratio.

You can also use the Smart Carver to change a photo's aspect ratio without distorting anything in the photo. For example, if you want to resize a photo to print at a certain size, you can paint the photo's subjects and then use the Smart Carver presets to contract or expand the photo's background vertically and horizontally.

In addition, you can use the new **Attract** and **Repel** tools to shape curves by attracting nodes or by pushing nodes away from other nodes in close proximity. To control the shaping effect, you can vary the size of the brush nib and the speed at which the nodes are attracted or repelled.

Shape tools *(New!)*

CorelDRAW X6 introduces four additional shaping tools that provide new creative options for refining vector objects. The new **Smear** tool lets you shape an object by pulling extensions or making indents along its outline. The size of the brush nib and the **Pressure** setting let you control the intensity of the effect, and you can choose between smooth curves or curves with sharp corners. Alternatively, you can use the pressure of your digital pen to determine the intensity of the smear effect.

The new **Twirl** tool lets you apply twirl effects to objects. The size of the brush nib lets you determine the size of the twirls, and the **Rate** setting lets you control the speed of the effect. You can also choose either a counterclockwise or a clockwise twirl.

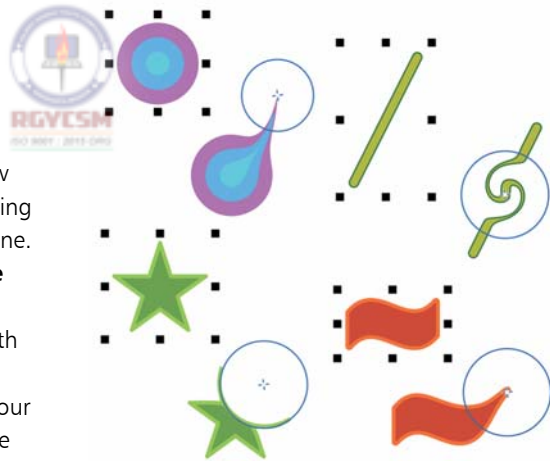

The new shaping tools provide creative options for refining vector objects.

Clip masks for groups of objects *(New!)*

With Corel PHOTO-PAINT X6, you can now apply a clip mask to a group of objects without modifying the individual objects within the

group. For example, you can adjust transparency levels for the whole group without altering the pixels of the individual objects.

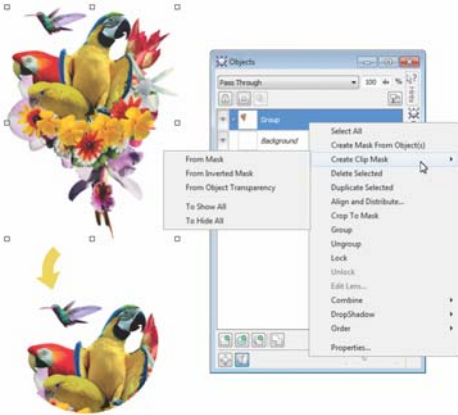

You can apply a clip mask to a group of objects.

Pass Through merge mode (New!)

Corel PHOTO-PAINT X6 introduces a new Pass Through merge mode that you can apply to groups, which gives you more control when applying a lens or special effect. If you choose Pass Through, the lens or effect will apply to all objects, including those layered below the group.

Multi-core processor support (New!)

CorelDRAW Graphics Suite X6 has been optimized for the latest multi-core processors. The increased support lets you continue working while the suite performs resource-intensive tasks in the background. The result is fast and responsive performance, which means less waiting when you export files, print multiple documents, or copy and paste large objects.

Native 64-bit support (New!)

CorelDRAW Graphics Suite X6 provides support for 64-bit processors, which allows you to work faster than ever before with large files in CorelDRAW and large images in Corel PHOTO-PAINT.

Adobe CS5 and Microsoft Publisher 2010 support (Enhanced!)

The enhanced import and export support for Adobe® Illustrator® CS5 and Adobe® Photoshop® CS5, as well as import support for Adobe® Acrobat® X and Microsoft® Publisher 2010, ensures that you can exchange files with colleagues and clients.

CoreDRAW® X6



Enhanced support for Adobe CS5, Adobe Acrobat, and Microsoft Publisher files facilitates file exchange with colleagues and clients.

Create layouts with ease

With new and improved master layer functionality, new temporary alignment guides, new advanced OpenType support, and enhanced complex script support for working with foreign language text, CorelDRAW Graphics Suite X6 makes it easier than ever before to lay out your project.

Master layers *(New and enhanced!)*

With CorelDRAW X6, the new and improved odd-page, even-page, and all-page master layers make it easier to create page-specific designs for multipage documents. If you are laying out multipage documents, such as brochures and flyers, it's now easy to incorporate page-specific headers, footers, and page numbers. For example, you might want to have different headers on even and odd pages.

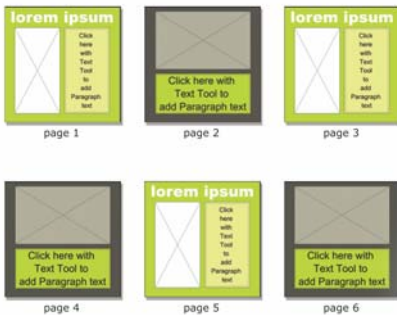

Examples of CorelDRAW X6 page layouts with different odd-page and even-page master layers

Page numbering *(New!)*

With CorelDRAW X6, the new **Insert page number** command helps you instantly add page numbers on all pages of a document, starting on a specific page, or at a particular number. This flexibility is ideal for working with multiple CorelDRAW files that will eventually become a single publication.

You can choose from alphabetic, numeric, or roman formats, and you can display page numbers in lower-case or upper-case letters. In addition, page numbers are automatically updated when you add or delete pages in your document. You can also insert a page number inside existing artistic or paragraph text.

Alignment guides *(New!)*

The new alignment guides help you position objects more quickly, appearing on the fly with suggested alignment to existing objects on the page. These temporary guidelines appear when you create, resize, or move objects in relation to other nearby objects. Alignment guides interactively connect the centers and the edges of objects, and you also can choose to display alignment guides from the edges of one object to the center of another object.

You can modify the default settings for alignment guides to suit your needs. For example, if you are working with a group of objects, you can display alignment guides for individual objects within the group, or for the bounding box of the group as a whole. In addition, you can specify margins for alignment guides to help you align objects at a set distance from the edge of another object. You can also specify whether the alignment guides follow only the margins or the actual edges of the object as well.

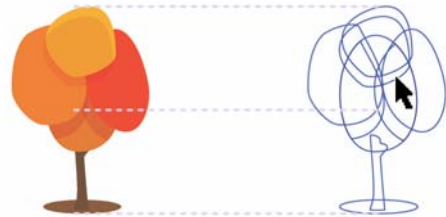

Using alignment guides to position objects quickly

Interactive frames *(New!)*

CorelDRAW X6 provides interactive frames that help you efficiently generate mock-ups of design ideas. The new empty PowerClip™ and text frame functionality lets you populate your designs with placeholder PowerClip and text frames, which makes it easier to preview a

layout before finalizing its individual content components.

You can now drag content over a PowerClip frame, and then choose either to add the content to the frame or to replace any existing frame content. PowerClip frames also now give you the option of centering content within the frame or scaling content to fit proportionally within the frame. In addition, you can easily create text frames from any closed curve object, and then edit the frames to take on any shape imaginable.

The interactive frame functionality has also been implemented in a collection of pre-designed picture frames included with the suite, giving you stylish, content-ready design assets that you can customize with ease.

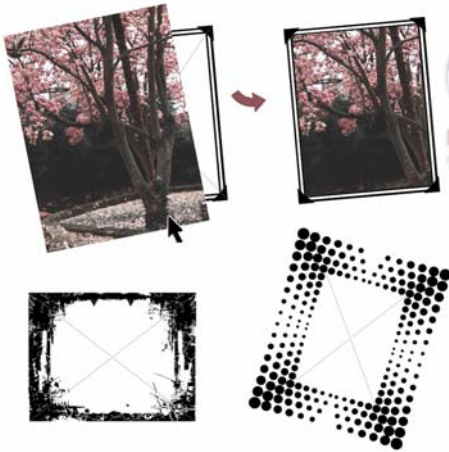

Choose from a collection of pre-designed interactive frames to frame your image.

Placeholder text (New!)

With CorelDRAW X6, the new **Insert placeholder text** command lets you right-click any text frame and immediately populate it with placeholder text. This makes it easier to assess the appearance of your document prior to finalizing its content.

For convenience and flexibility, you can also use custom placeholder text in any language supported by CorelDRAW. You simply create an RTF file containing the text that you want to use, save it to the default placeholder text folder, and CorelDRAW X6 will use that text whenever you invoke the **Insert placeholder text** command. For more information about creating a custom placeholder text file, “Placeholder text” on page 210.



You can create custom placeholder text for your documents.

Advanced OpenType support (New!)

The reengineered text engine lets you take greater advantage of advanced OpenType typography features, such as contextual and stylistic alternates, fractions, ligatures, ordinals, ornaments, small caps, swashes, and more. OpenType fonts are based on Unicode, which makes them ideal for cross-platform design work. In addition, the extended character sets offer outstanding language support.

Accessible from the **Object properties** docker, the OpenType features let you choose alternative appearances for individual characters, or glyphs, to suit your stylistic

preference, provided that the font supports advanced OpenType. For example, you can apply a different number, fraction, or ligature glyph to achieve a certain look for your text. In addition, you can let CorelDRAW prompt you when an OpenType feature is available for the selected text by enabling the Interactive OpenType option.

1234567

Lorem Ipsum 123456789

Lorem Ipsum 123456789

Lorem Ipsum 1/5 13/256

1^{er} 2^e 3^r

OpenType fonts let you choose alternate appearances for selected characters.

Complex script support (Enhanced!)

With CorelDRAW X6, the complex script support built into the overhauled text engine ensures proper typesetting for glyphs used by Asian and Middle Eastern languages.

Welcome

أهلاً وسهلاً

欢迎

歡迎

ברוך הבא

환영합니다

Text engine improvements ensure that multilingual glyphs display correctly in your documents.

Design with style and creativity

With its rebuilt styles engine, new **Object styles** docker, new color styles implementation, new color harmony functionality, and content-ready picture frames, CorelDRAW Graphics Suite X6 helps you focus on bringing your unique sense of style and creativity to your designs.

Styles engine and docker (New!)

In CorelDRAW X6, the revamped styles engine introduces a new **Object styles** docker that simplifies the creation, application, and management of styles. A style is a set of properties that governs the appearance of objects. CorelDRAW X6 also introduces new style sets, which are groups of styles that make it easier to have consistent formatting across multiple objects, produce iterative versions, and apply formatting with speed and consistency.

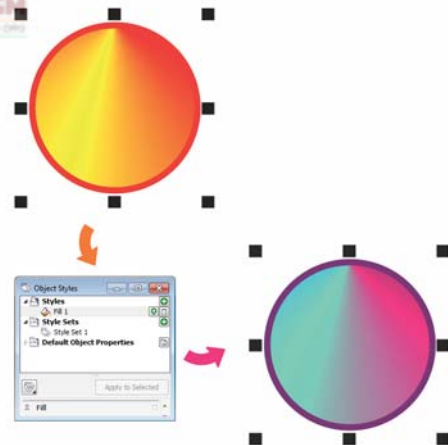

You can quickly change the look of an object by applying a style set.

You can create and apply styles and style sets to graphic objects, artistic and paragraph text, callout and dimension objects, and objects

created with the **Artistic media** tool. For example, you can define an outline style by specifying attributes such as outline width, color, and line type. For text objects, you can define a character style by specifying font type, font style and size, text color, background color, character position, caps and more.

With style sets, you can group multiple styles, which lets you combine properties from different types of styles. For example, you can use a style set to define fill and outline properties for a graphic object, or you can define character and paragraph styles to set the appearance of paragraph text. This makes it faster and easier to later adjust those properties, which is especially convenient for creating iterative designs. You can also create child styles or style sets that retain some but not all properties of the parent style or style set. This is particularly useful when working with long documents. For example, you can assign a parent character style for headings and a child character style for subheadings.

Color styles (New!)

The new **Color styles** docker lets you add the colors used in a document as color styles, which makes it easier than ever before to implement a color change throughout a project. To create a color style from an object, simply drag the object to the **Color styles** docker. If you apply that color style to other objects, you can quickly change the color style and all objects that have this style are instantly updated.

In addition, you can break the link between an object and a color style at any time, so you can edit the object independently. You can also convert color styles to different color modes or to spot colors to prepare your document for production printing.

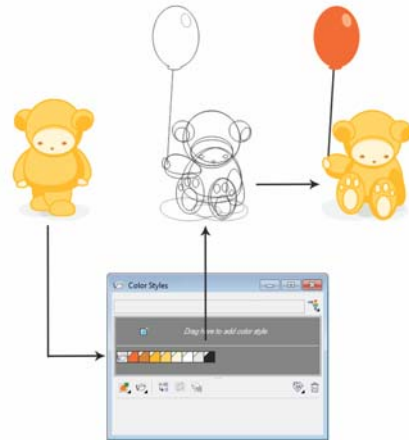

Managing document colors by using the **Color styles** docker

Color harmonies (New!)

The new color harmony functionality lets you group color styles so you can quickly and easily produce iterative designs with varying color schemes.

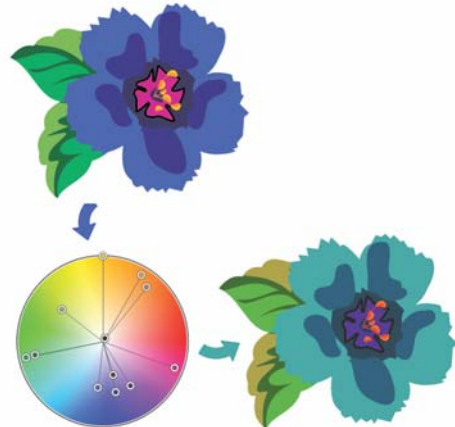

Color harmonies let you change combinations of colors easily.

By combining two or more color styles into a harmony, you are linking the colors into a hue-

based relationship. This lets you modify all colors simultaneously, altering the color composition of your artwork in one step, and quickly prepare a variety of alternate color schemes. You can also edit the individual color styles in a harmony.

In addition, you can create a special type of color harmony called a gradient, which consists of one master color style and a number of varying shades of that color. When you alter the master color, the gradient colors automatically adjust to the same degree that the master color was altered. This is especially useful when outputting multiple color variations of the same design.

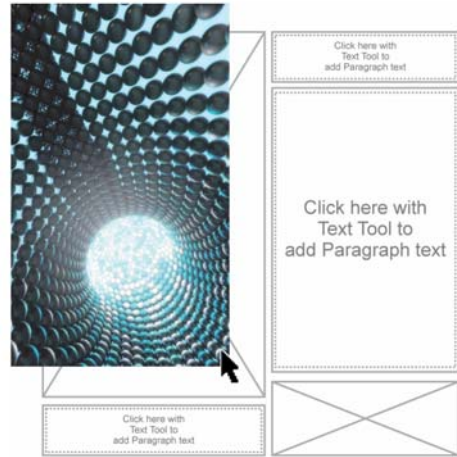

Adding an image to an empty PowerClip frame

Content-ready pre-designed frames

(New!)

With CorelDRAW Graphics Suite X6, the collection of frames included in the content library has been enhanced to support the new empty PowerClip functionality. This lets you instantly populate the frames with photos or graphics, saving you time and effort. In addition, some of the included frames are text-ready, so you can immediately add your own custom text message.





Image created by
Gabriel González Díaz
Mexico

Part Two

Getting Started



Chapter 4: CorelDRAW Basics

Workspace overview **28**

Starting a document **33**

Zooming, panning, and scrolling **34**

Creating objects **34**

Working with bitmaps **36**

Selecting, sizing, and transforming objects **37**

Coloring and styling objects **38**

Positioning objects **42**

Grouping and combining objects **43**

Organizing objects **43**

Working with pages **44**

Sharing your work **44**

Setting preferences **46**

Chapter 4: CorelDRAW Basics

This chapter introduces you to the CorelDRAW workspace and provides an overview of basic tasks, such as starting and viewing documents, modifying and organizing objects, and creating page layouts. Additional topics include sharing work and setting preferences. As you learn to use CorelDRAW, this chapter can help identify tasks and features that you may want to explore further in the Help.

Workspace overview

The CorelDRAW workspace provides a wide range of tools and commands for creating unique graphic designs. This section describes the application window and the toolbox.

Application window

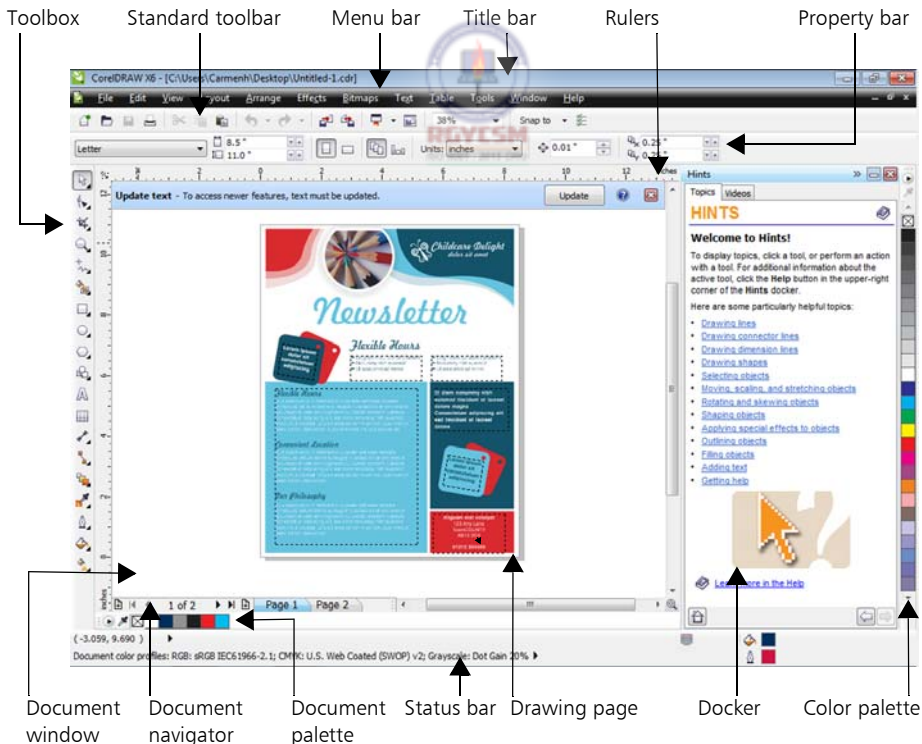

The following list describes the main components of the CorelDRAW application window.

- The **toolbox** contains tools for creating, filling, and modifying objects in a document.
- The **standard toolbar** contains shortcuts to basic menus and commands, such as opening, saving, and printing documents. Additional toolbars contain shortcuts for more specific tasks.
- The **menu bar** contains drop-down menus of related commands.
- The **title bar** displays the title of the current document.
- The **property bar** contains controls that change according to the active tool. For example, when you use the **Text** tool, the property bar changes to display controls for creating and editing text.
- A **docker** lets you access commands and settings that are associated with a specific tool or task.
- The horizontal and vertical **rulers** let you determine the size and position of objects in a document.
- The **document navigator** lets you add pages to a document, or move from page to page within a document.
- The **document window** is the workspace area that is bordered by scroll bars and other controls. It includes the drawing page and surrounding area.
- The **drawing page** is the rectangle that represents the printable section of the document window.

- The **Document palette** lets you keep track of the colors that are used in a document.
- The **color palette** is a dockable bar that contains color swatches.
- The **status bar** displays information about the properties of an object, such as type, size, color, and fill. Color proofing status, color profiles, and other information about document colors are also displayed.

Toolbox

The toolbox contains a range of tools that you can use for specific drawing and editing tasks. Some tools let you draw shapes, and other tools let you apply colors, patterns, or other types of fills to objects.

Some tools belong to flyouts, which are groups of related tools. A small arrow in the lower-right corner of a toolbox button indicates that the tool belongs to a flyout. The last-used tool in the flyout appears on the button. You can access the tools in a flyout by clicking the flyout arrow.

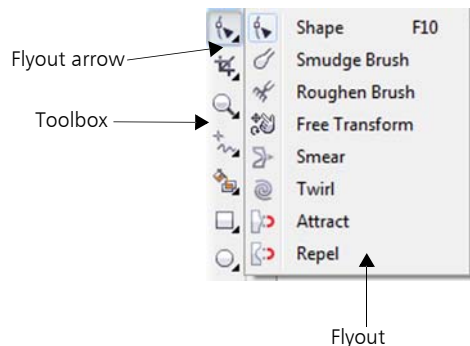

*In the default workspace, clicking the flyout arrow on the **Shape** tool opens a flyout of related tools.*

The following section summarizes the main categories of tools that are available in the toolbox. For more information about specific tools, see “Workspace tools” in the Help.

Pick tool



The **Pick** tool and the **Freehand pick** tool let you select, size, skew, and rotate objects.



Shape tools



Shape tools let you draw many different shapes, including rectangles, ellipses, stars, polygons, and spirals. Additional tools in this category (not shown here) let you draw shapes such as smileys, arrows, banners, and flowcharts.

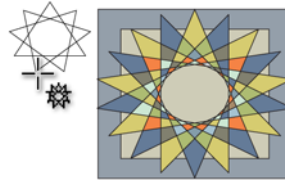

Shape editing tools



Shape editing tools let you change the shape of an existing object.



Curve tools



Curve tools let you draw lines and curves, such as freehand lines, straight lines, and Bézier curves. You can also use the **Artistic media** tool to spray images, draw calligraphic lines, or add brushstrokes.



Fill tools



Fill tools let you apply various fills to objects, such as uniform, fountain, and mesh fills.



Interactive tools



Interactive tools let you apply special effects to objects, such as blends, contours, drop shadows, extrusions, and transparencies.



Cropping and erasing tools



Cropping and erasing tools let you remove parts of a document.

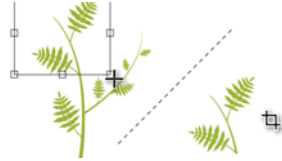

Dimension tools



Dimension tools let you draw slanted, straight, and angular dimension lines to measure parts of objects in a document.



Connector tools



Connector tools let you draw lines that connect objects in diagrams and flowcharts.

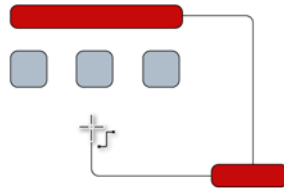

Text tool



The **Text** tool lets you type words directly on-screen as artistic or paragraph text.



Table tool



The **Table** tool lets you draw and edit tables.

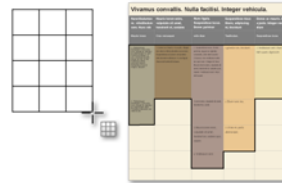

Zoom tool



The **Zoom** tool lets you change the magnification level in the document window.



For more information about workspace components, see “CorelDRAW workspace tour” in the Help.

Starting a document

When you start a new document (**File ▶ New**), you can set various document properties in the **Create a new document** dialog box.

You can name the document, set the page size, select a color mode, such as CMYK or RGB, and set color profiles.

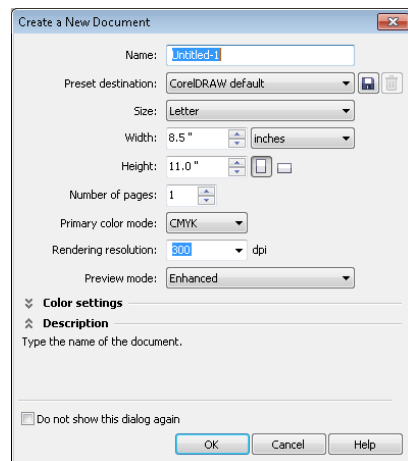

The **Create a new document** dialog box lets you specify a wide range of document properties.

Zooming, panning, and scrolling

You can change the view of a document by zooming in to get a closer look or by zooming out to see a larger area. You can experiment with a variety of zoom options to determine the amount of detail that you want.

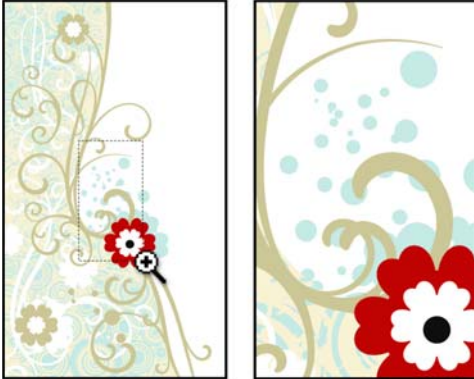

Left: The **Zoom** tool is used to select an area to magnify.
Right: The area is magnified.

Panning and scrolling are two additional ways to view specific areas of a document. When you work at high magnification levels or with large documents, you may not be able to see all the content at the same time. Panning lets you “grab” the document and move it around in the document window to focus on a desired area. Scrolling lets you move the document up, down, or sideways in the document window so that you can view the areas that are currently hidden.

Creating objects

Objects are the building blocks of a document. By using the tools in the toolbox, you can create different types of objects: shapes, lines and curves, text, and tables.

Drawing common shapes

CorelDRAW provides many tools that let you draw common shapes, such as rectangles, circles, stars, and arrows. After you create a shape, you can modify it by stretching it, applying a pattern fill, or adding a drop shadow.

One of the simplest shapes that you can create is a rectangle.

Click the **Rectangle** tool  in the toolbox. On the drawing page, drag to draw the rectangle.



The **Rectangle** tool is used to draw a single rectangle (left), which can be used as a graphic element in a finished project (right).

You can create objects of different shapes by using the following tools:

- The **Ellipse** tool lets you draw circles and ellipses.
- The **Polygon** tool lets you draw polygons.
- The **Graph paper** tool lets you draw a grid.
- The **Spiral** tool lets you draw symmetrical and logarithmic spirals.

- The **Basic shapes** tool lets you draw a full set of shapes, such as hexagrams, smileys, and right-angle triangles.
- The **Arrow shapes** tool lets you draw arrows with a specified shape, direction, and number of arrowheads.
- The **Flowchart shapes** tool lets you draw flowchart symbols.

Creating lines and curves

If you want to create your own unique shapes, you can use one of the curve tools that let you draw an almost unlimited variety of shapes. Before you get started, however, it's a good idea to get familiar with the following basic concepts.

After drawing a line, you can convert it to a curve. This is helpful when you want to make detailed changes to the basic shape of a line. When you convert a line to a curve, you are essentially reducing the line to a series of points, called nodes. By moving the nodes, you change the line's shape.

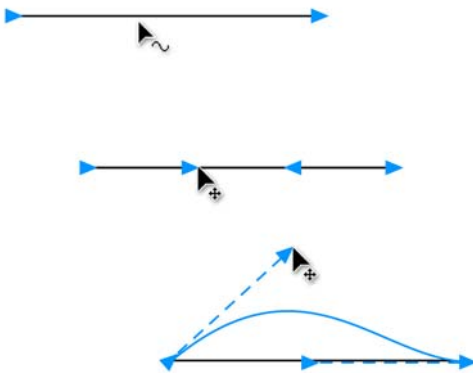

Top: Straight line. Middle: The line has been converted to curves and now contains curve nodes. Bottom: The curve is shaped by manipulating the nodes.

A line in which the starting point and endpoint do not meet is called an open path. You can join the points to make a closed path. This is useful for adding a fill to the area enclosed by the line.

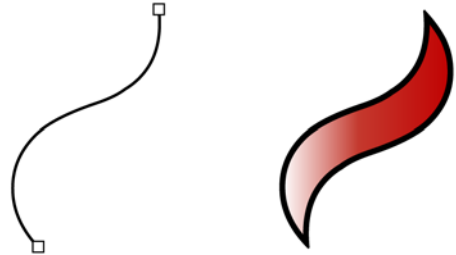

Left: Open path. Right: Closed path with a fill added.

CorelDRAW provides many tools for drawing lines and curves, including the following:

- The **Freehand** tool lets you draw line segments and curves by using a mouse or pen tablet.
- The **Artistic media** tool provides access to four additional tools:
 - The **Brush** tool lets you draw lines that look like brushstrokes.
 - The **Sprayer** tool lets you spray objects, such as snowflakes or bubbles, along a path.
 - The **Calligraphic** tool lets you draw lines that resemble strokes drawn with a calligraphy pen.
 - The **Pressure** tool lets you draw lines that resemble strokes drawn with a pressure-sensitive pen.
- The **Pen** tool lets you draw curves and straight lines one segment at a time.

Creating text

You may need to include text in your documents. CorelDRAW lets you create two types of text:

- *Paragraph text* is contained within a text frame. You can change many common formatting properties of paragraph text, such as font type and size, text color, and font style. Paragraph text is ideal for larger blocks of text.
- *Artistic text* is not contained within a text frame, and you can add special effects to it such as contouring and drop shadows. Artistic text is ideal for logos, banners, and headlines.

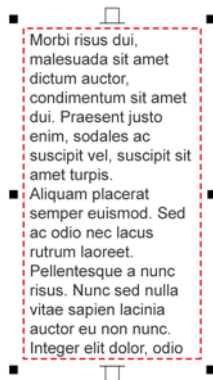

Left: Paragraph text. Right: Artistic text, formatted as a logo.

You can create both paragraph and artistic text by using the **Text** tool. For more information, see “Working with Text” on page 105.

Creating tables

One way to organize graphic and text objects in a document is by creating a table and inserting the objects into the table cells. Tables

offer a quick way to create a pleasing layout for your documents.

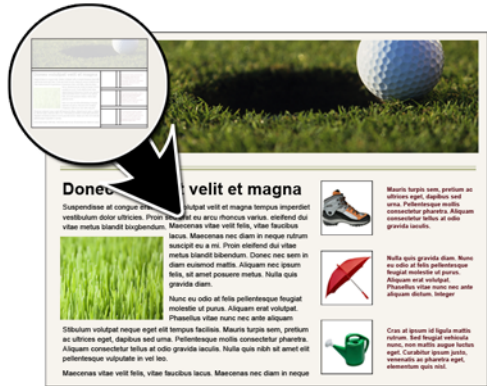

The **Table** tool was used to design this Web page.

You can create tables by using the **Table** tool. When you click the **Table** tool, controls for the tool become available on the property bar. After specifying the number of rows and columns, you can simply drag diagonally on the drawing page to create the table.



Working with bitmaps

The document that you create with CorelDRAW is a vector graphic. Vector graphics are resolution-independent, which means that the graphic is not compromised when you scale or distort it. Vector graphics are based on mathematical equations, which remain the same regardless of the changes you make.

When you import a photograph into CorelDRAW, the photograph is imported as a bitmap image. Bitmap images are based on pixels, which are tiny units of color. You can think of a vector graphic as composed of lines and fills, and a bitmap image as composed of a mosaic of colors.



Left: Vector image with smooth lines. Right: Pixelated bitmap image that demonstrates the “mosaic” nature of bitmap files.

There are two ways in which you can work with bitmap images in CorelDRAW: You can insert a bitmap into your document, and you can open Corel PHOTO-PAINT from within CorelDRAW to edit a bitmap.

Inserting bitmaps

When you import a bitmap image into CorelDRAW, you can either embed it or link it to an external file. When you link to an external file, any edits that you make to the external file are automatically applied to the imported file in CorelDRAW. After you import a bitmap, the status bar provides information about the color mode, size, and resolution of the bitmap. When you import the bitmap into the document, you can make changes to the bitmap by using the **Edit bitmap** feature in CorelDRAW.

Editing bitmaps

You can access Corel PHOTO-PAINT, a complete bitmap-editing program, from

within CorelDRAW. When you finish editing a bitmap, you can quickly resume your work with CorelDRAW.

 To open a bitmap in Corel PHOTO-PAINT, click the **Edit bitmap** button on the property bar.

Selecting, sizing, and transforming objects

After adding an object to your document, you may want to modify the object. CorelDRAW provides several tools that let you select, resize, or transform objects.

To modify an object, you must first select it. You can select an object by using the **Pick** tool.

After you select an object with the **Pick** tool, a bounding box with an “X” at the center appears around the object. The bounding box contains control handles that allow you to transform the object.

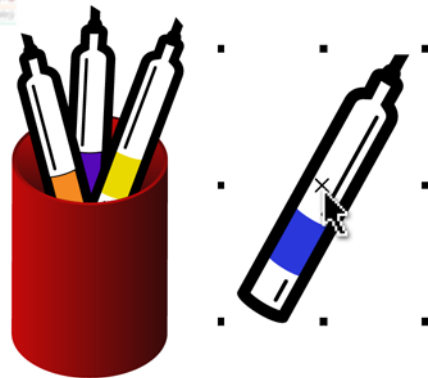

The object on the right has been selected, which is indicated by a bounding box with an “X” in the center.

You can change an object by sizing, skewing, stretching, rotating, or mirroring it.

- **Sizing** lets you change the width and height of an object.



- **Mirroring** lets you create a horizontal or vertical mirror image of an object.



- **Skewing** lets you slant an object to one side.



Coloring and styling objects

In addition to transforming objects, you can style your objects artistically. For example, you can apply a unique outline or fill, or add a drop shadow to create the illusion of depth. You can also make objects transparent.

- **Stretching** lets you change the height and width of an object nonproportionally.

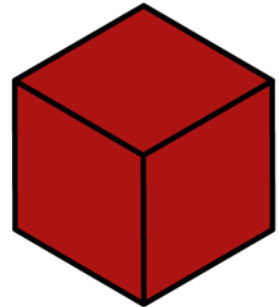
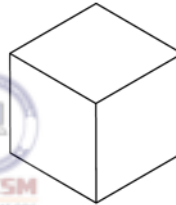

A solid red fill has been added to the bottom cube.

- **Rotating** lets you turn an object around its center axis or a point relative to its position.





A blue fill and a drop shadow have been applied to the bottom rectangle, giving it a three-dimensional appearance.

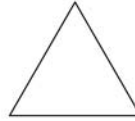

Upper left: Triangle outline with no formatting applied. Lower right: Triangle outline formatted with color and a dashed-line pattern.

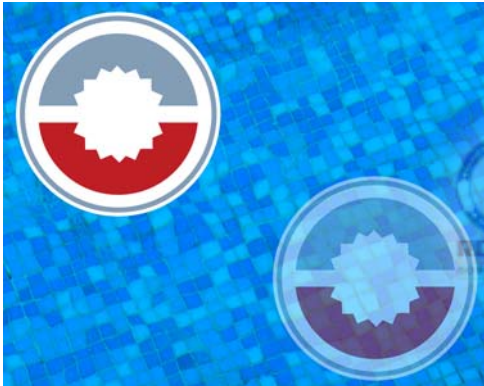

A transparency effect has been applied to the bottom circle, so that it appears to be under water.

Formatting outlines

You can change the outline of an object in various ways. Depending on your design needs, you can choose a different outline color, thickness, or style (such as a dashed or dotted line).

 To change the appearance of outlines, you can use controls in the **Outline pen** dialog box, the **Outline** page of the **Object properties** dock, or the property bar.

A list of preset arrowheads is also available. To add arrowheads to the starting point or endpoint of a line, you can choose a preset from the list or create a custom arrowhead.

Choosing fills

CorelDRAW provides a wide range of fills to help you add patterns and texture to your objects. You can fill an object with one color, or with a blend of two or more colors. Or you can select a more complex fill, such as a texture or pattern, or create your own fill.

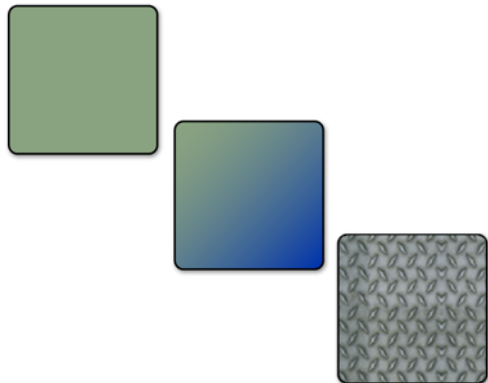

Top to bottom: Uniform fill, fountain fill, and pattern fill applied to objects.

 To add a fill to an object, click either the **Fill** tool or the **Interactive fill** tool.

The **Fill** tool lets you choose one of five fill types, each with a wide range of options. The **Interactive fill** tool lets you apply a fill dynamically by using property bar controls while drawing in the document window. The following list describes the types of fills that are available for each tool.

Fill tool

- The **Uniform fill** is a single-color fill.
- The **Fountain fill** is a blended fill of two or more colors.
- The **Pattern fill** is a patterned design, such as a floral wallpaper design.
- The **Texture fill** has a textured effect that mimics various surfaces, such as marble, ocean surface, and moon terrain.
- The **PostScript fill** supports transparency in a range of patterns.

Interactive fill tool

- The **Interactive fill** lets you create a fountain fill and apply changes to it in real time.
- The **Mesh fill** lets you manipulate a mesh grid to control the colors and blends in a custom fountain fill.

For more information, see “Filling objects” in the Help.

Adding transparency

You can apply transparency to create a realistic rendering of objects such as water and glass.

When you add transparency to an object, anything behind the object shows through.



*Transparency was added to the object on the left to create the illusion of water, and to the object on the right to create the illusion of glass. The **Drop shadow** tool was used to intensify the effect in both objects.*

You can adjust the measure of transparency to determine how opaque the object is. A fully opaque object completely blocks anything behind it, whereas a fully transparent object is invisible.

To apply transparency to an object, you have several choices. You can use the **Interactive transparency** tool to apply a transparency fill, or you can use a transparency lens effect. In addition, you can control the way the transparency is blended in the object, and you can copy transparencies from one object to another. You can also specify whether to apply the transparency to the fill or to the object outline, or to both.

Adding effects

CorelDRAW offers a range of tools that you can use to add three-dimensional effects to objects.

- **Extrusions**

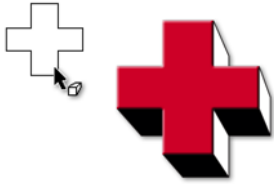

- **Drop shadows**



- **Contours**

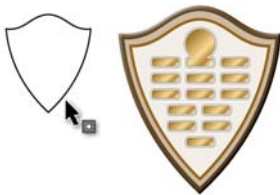

- **PowerClips**



- **Bevels**



- **Chamfers**

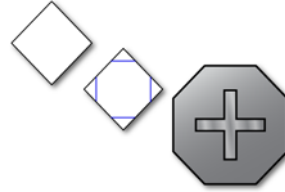

Reusing color and objects

To save time and maintain a uniform look in your document, you can reuse colors and objects.

You can sample color from anywhere in your document and then copy that color to another object.



The orange color is sampled from the graphic on the left and applied to the graphic on the right.

 To sample color, click the **Color eyedropper** tool, and click the color. The **Color eyedropper** tool automatically switches to the **Apply color** mode. To apply the color, point to an object, and click.

When you use a color in your document, the color is added to the **Document** palette, which is docked at the bottom of the application window when you start a new document or open an existing document.

Colors are added to the **Document** palette when you add a color from one of the color libraries, when you sample a color from another document or another application, and when you apply fills to objects.

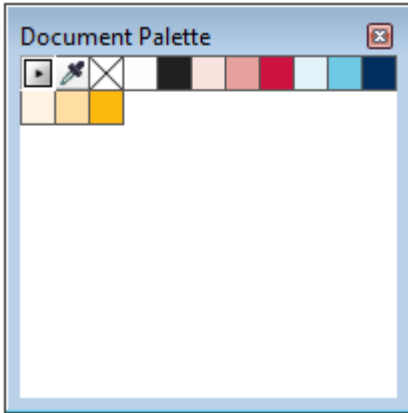

The **Document** palette is automatically updated as you add colors to your document. You can use this palette to create a color scheme for your project.

To reuse objects in your documents, you can either copy and paste the objects, or you can duplicate them. Using the first method, you can copy an object to the Clipboard and then paste the object in your document. Using the second method, you can quickly create multiple duplicates of the object and place them in your document.

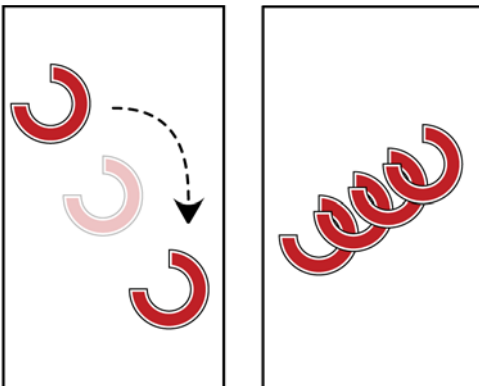

Left: The object has been copied and pasted. Right: The object has been duplicated.

To create one copy of an object, click **Edit** ▶ **Copy**. To create a series of duplicates, click **Edit** ▶ **Step and repeat**.

Positioning objects

CoreDRAW provides several tools to help you position and align objects on the page. You can use these tools to avoid small gaps or misalignments that are not apparent on-screen but become noticeable after printing.

You can use snapping to align an object with another object in a document. When snapping is turned on, snap points appear in various locations around an object, such as the corner, center, or edge.

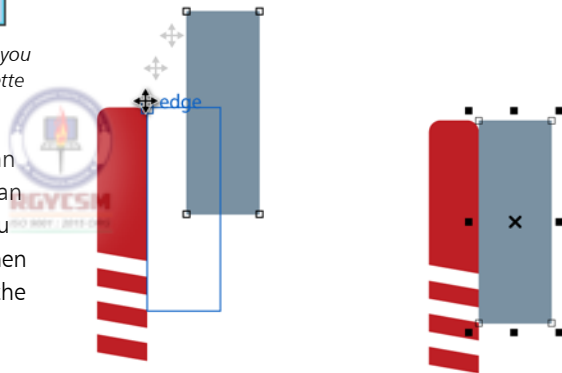

Left: The blue rectangle is dragged down to snap to the red rectangle. Right: The two objects are snapped together.

To turn on object snapping, click **View** ▶ **Snap to** ▶ **Snap to objects**.

If you want to align an object with another object but do not want to snap directly to the object, you can use dynamic guides. Dynamic guides are temporary guidelines that are based on one of the following snap points of an object: center, node, quadrant, or text baseline. You can drag the object along the

dynamic guide. The distance from the base object is measured as you move the object.

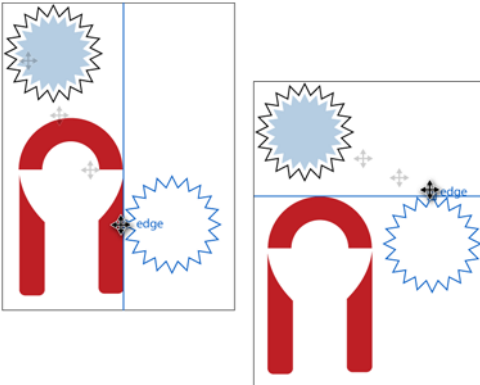

Left: A vertical dynamic guide is used to align objects.
Right: A horizontal dynamic guide is used to align objects.

To turn on dynamic guides, click **View ▶ Dynamic guides**.

You can also use the document grid to align objects within the document window. The document grid is a series of intersecting lines in which each small square acts as a snapping point. You can reduce the size of these squares for more precise alignment in your document.

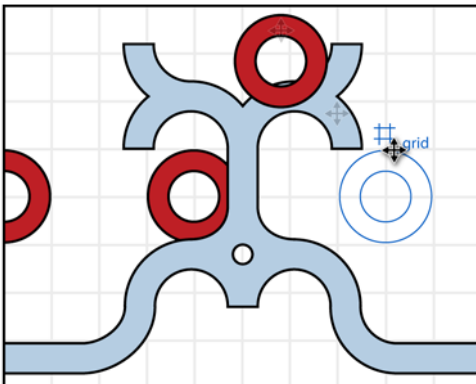

Objects can be placed on the drawing page by aligning them with a grid.

To display the document grid, click **View ▶ Grid ▶ Document grid**.

Grouping and combining objects

You may want to make changes to a group of objects or move them without changing their position in relation to each other. CorelDRAW lets you group objects to manage them more easily. When you group objects, each object retains its own properties. When you finish working with the objects as a group, you can ungroup them and work on each one individually.



The three chair images are selected as a group.

To group objects, marquee select the objects, and click **Arrange ▶ Group**.

By combining two or more objects, you can create a single curve object that has the fill and outline attributes of the last selected object. You can edit this curve object whenever necessary. In addition, you can combine objects as a way of creating objects with holes.

To combine objects, click **Arrange ▶ Combine**.

For more information, see “Combining objects” in the Help.

Organizing objects

The more objects you add to your document, the more difficult it is to find and select specific objects. To organize objects, you can add layers

to your document. Layers make it easier to view and work with multiple objects simultaneously.

The **Object manager** docker lets you add, move, and delete layers in a document. You can set up layers before you begin working on your document, or you can add them as needed and then move existing objects to the newly added layers.

 To open the **Object manager** docker, click **Tools ▶ Object manager**.

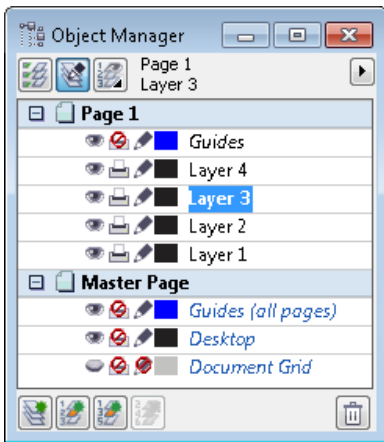

The **Object manager** docker lets you select and modify page layers.

For more information about layers, see “Working with layers” in the Help.

Working with pages

Depending on your desired output, you can customize the look of your pages by specifying different page layouts, such as a booklet, tent card, or brochure. You can also toggle the page orientation between landscape and portrait, and you can create a custom page size.



Left: Portrait orientation. Right: Landscape orientation.

 To set the page size, click **Layout ▶ Page setup**. You can select from a long list of common paper sizes, including legal, business card, and various envelope sizes.

You can specify a background for your pages. A background consists of a single color or a bitmap, which is tiled to fit the page.



Left: Page with a solid red background. Right: Page with a tiled bitmap background.

 To add a background to your page, click **Layout ▶ Page background**.

Sharing your work

To share your finished document with others, you can print a copy on a personal printer. Or for high-quality output, such as signs or vehicle wraps, you can send your document to a commercial printer. You can also export your

work to a different file format, such as Adobe® Portable Document Format (PDF) or Adobe Illustrator (AI).

If your document has multiple layers, and you do not want to print them all, you can specify which ones to print. Make sure that the layers to be printed are visible and enabled for printing in the **Object manager** docker.

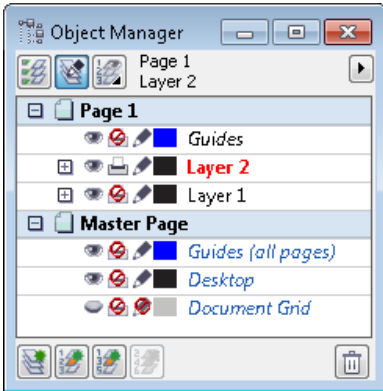

In this example, the objects on Layer 2 are visible in the document window and are enabled for printing. The objects on Layer 1 are visible, but will not appear in the printed copy of the document.

To print to a personal printer, click **File ▶ Print**. In the **Print** dialog box, choose a printer from the **Printer** list box, and choose a print range option.

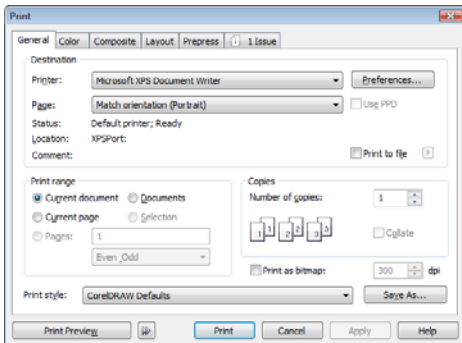

The **Print** dialog box lets you set printing preferences for your document.

You can preview your work before printing to ensure that everything will appear as it should.

To preview a print job, click **File ▶ Print preview**.

If you are using a print service provider, you must ensure that your document meets the provider's criteria. Consult with the print service provider if you do not have this information, so that you know which options to enable in the document.

To prepare a print job for a print service provider, click **File ▶ Collect for output**. Follow the instructions in the **Collect for output** wizard.

To export your work to another file format, click **File ▶ Export**, and choose a file format.

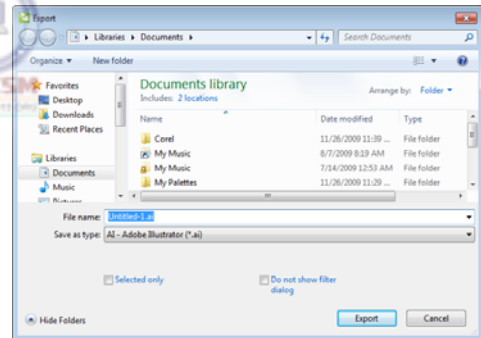

Export dialog box

Depending on which file format you choose when exporting a file, you can set additional options. For example, with the Adobe Illustrator (AI) file format, you can choose a specific version of Adobe Illustrator in the **Export** dialog box.

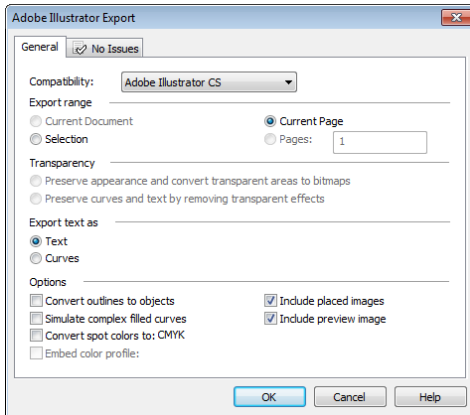

You can set export options for Adobe Illustrator files.

When you save your work as a PDF file, you can use PDF presets, which optimize the file for various types of output, such as document distribution, prepress, and the Web.

 To save your work as a PDF file, click **File ▶ Export**. From the **Save as type** list box, choose **PDF - Adobe Portable Document Format**.

Setting preferences

You can set many different preferences in CorelDRAW to customize various features. The following table lists and describes three examples of these preferences.

Preference	Description	How to set
Unit of measure	The selected unit of measure for the horizontal and vertical rulers, such as inches, pixels or points	Click View ▶ Setup ▶ Grid and ruler setup , and click Rulers . In the Units area, choose a unit of measure for the horizontal and vertical rulers.
Backup files	The folder location to save backup files, and any auto-backup settings	Click Tools ▶ Options . In the Workspace list of categories, click Save to access the backup file settings.
Nudge distance	The increment by which you move an object when you press an arrow key	Click View ▶ Setup ▶ Grid and ruler setup , and click Rulers . Type a value in the Nudge box.

Chapter 5: Corel PHOTO-PAINT Basics

Workspace overview **48**

Acquiring images **57**

Cropping and rotating **57**

Changing image size and resolution **58**

Changing color modes **60**

Retouching **60**

Adjusting color and tone **62**

Working with masks **64**

Working with objects and lenses **65**

Sharing your work **66**

Setting preferences **67**

Chapter 5: Corel PHOTO-PAINT Basics

This chapter introduces you to the Corel PHOTO-PAINT workspace and provides an overview of basic tasks, such as bringing in images from your scanner or digital camera, adjusting image size and resolution, and retouching photos to fix common problems. Additional topics include using masks, objects, and lenses in image editing, and sharing work by exporting to different file formats or by using ConceptShare™. As you learn to use Corel PHOTO-PAINT, this chapter can help identify tasks and features that you may want to explore further in the Help.

Workspace overview

The Corel PHOTO-PAINT workspace provides a wide range of tools and commands for viewing and editing images. This section describes the application window and the toolbox.

Application window

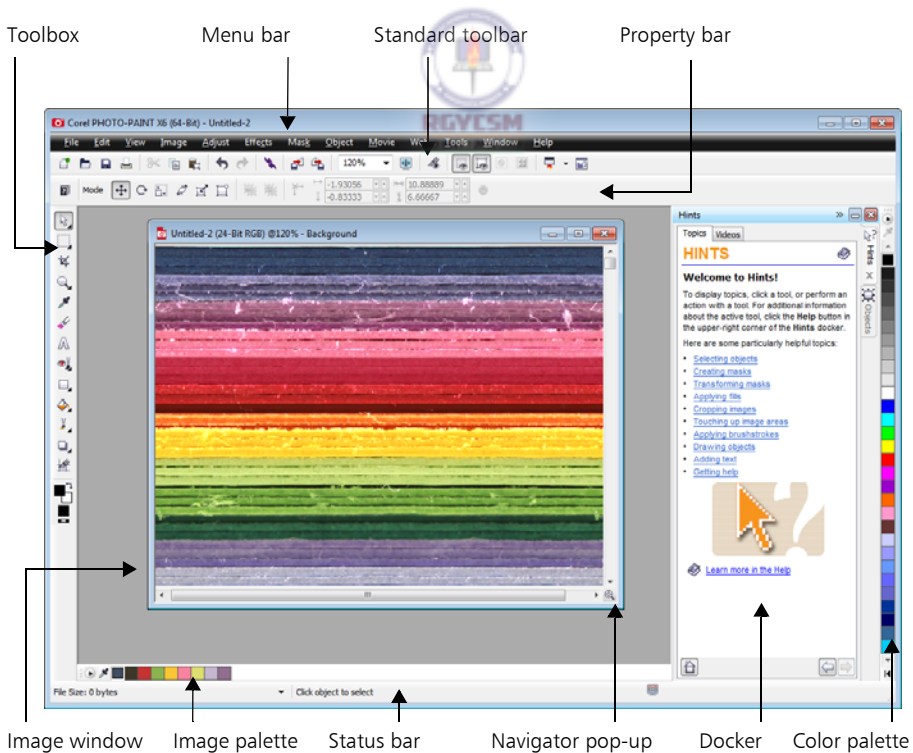

The following list describes the main components of the Corel PHOTO-PAINT application window.

- The **toolbox** contains tools for editing, creating, and viewing images, as well as the color control area, which lets you choose colors and fills.
- The **menu bar** contains drop-down menus of related commands.
- The **standard toolbar** contains shortcuts to basic menu commands, such as opening, saving, and printing. Additional toolbars contain shortcuts for more specific tasks.

 To access a toolbar, click **Window ▶ Toolbars**, and click a toolbar name.

- The **property bar** contains controls that change according to the active tool. For example, when you use the **Zoom** tool, the property bar changes to display controls for zooming.
- The **image window** is the area where the active image appears.
- The **Image palette** lets you keep track of the colors that are used in an image.
- The **status bar** displays information about the active image, the active tool, the available memory on your computer, and the color proofing status. The status bar also displays tips related to the active tool.
- The **Navigator pop-up** button lets you find and focus on a specific area of the image. This feature is available only when the entire image is too large to be viewed all at once.
- A **docker** lets you access additional commands and image information.

Dockers can be kept open while you work on an image. They can also be attached (docked) to either side of the application window, or floated (undocked) and moved to wherever you need them as you work. Dockers can also be minimized to save valuable screen space.

 To open a docker, click **Window ▶ Dockers**, and click a docker.

- A **color palette** is a collection of color swatches. You can change the foreground and fill colors by using the default color palette, which appears on the right side of the application window.

 To access additional color palettes, click **Window ▶ Color palettes**, and click a color palette.

Toolbox

The toolbox contains tools for editing, creating, and viewing images. Some tools belong to flyouts, which are groups of related tools. A small arrow in the lower-right corner of a toolbox button indicates that the tool belongs to a flyout. The last-used tool in the flyout appears on the button. You can access the tools in a flyout by clicking the flyout arrow.

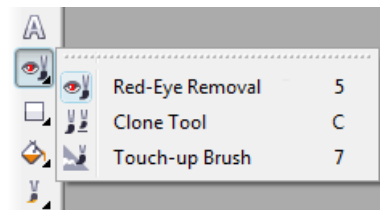

Example of a flyout

The following section briefly describes the tools that are located in the toolbox.

Pick tools



The **Object pick** tool lets you select, position, and transform objects.



The **Mask transform** tool lets you position, size, and rotate editable areas.



Mask tools



The **Rectangle mask** tool and the **Ellipse mask** tool let you define rectangular and elliptical editable areas.



The **Freehand mask** tool lets you define irregularly shaped or polygonal editable areas.



The **Lasso mask** tool lets you define editable areas that are irregular in shape and surrounded by pixels of similar colors.





The **Magnetic mask** tool lets you position a mask marquee along the edge of an image element. An edge is indicated by an outline that is colored in contrast to the surrounding area.



The **Magic wand mask** tool lets you define editable areas of irregular shape. Pixels that are adjacent to, and similar in color to, the first pixel that you click are included in the editable area.



The **Brush mask** tool lets you define an editable area by painting it with a brush.



Crop tool



The **Crop** tool lets you remove unwanted areas and straighten crooked images.



Zoom tools



The **Zoom** tool lets you change the magnification level in the image window.

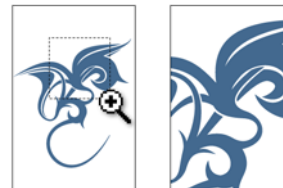



The **Pan** tool lets you drag areas of an image into view when the image is larger than the image window.



Eyedropper tool



The **Eyedropper** tool lets you sample colors from an image.



Eraser tool



The **Eraser** tool lets you erase areas of an object or image to reveal the underlying object or background.

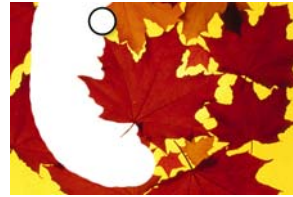

Text tool



The **Text** tool lets you add text to your image and edit existing text objects.



Touch-up tools



The **Red-eye removal** tool lets you remove the red-eye effect from the eyes of photo subjects.





The **Clone** tool lets you duplicate part of an image and apply it to another part of the same image or to another image.



The **Touch-up brush** tool lets you remove image imperfections, such as tears, scratch marks, and wrinkles, by blending textures and colors.



Shape tools



The **Rectangle** tool, **Ellipse** tool, and **Polygon** tool let you draw rectangles, squares, ellipses, circles, and polygons.

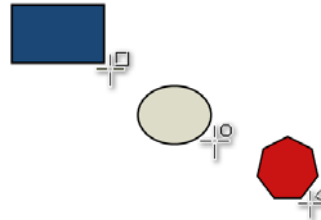

The **Line** tool lets you draw single or joined straight-line segments by using the foreground color.



The **Path** tool lets you create and edit paths.

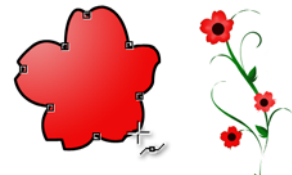

Fill tools



The **Fill** tool lets you fill areas with one of four fill types: uniform, fountain, bitmap, or texture.

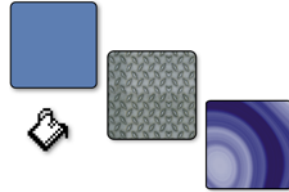

The **Interactive fill** tool lets you apply a fill to an entire image, object, or selection and then adjust the fill directly in the image window.



Brush tools



The **Paint** tool lets you paint on an image by using the foreground color.



The **Effect** tool lets you correct color and tone.



The **Image sprayer** tool lets you load one or more images and apply them in a repeating sequence as you paint.





The **Undo brush** tool lets you restore image areas to their appearance before your last brushstroke.



The **Replace color brush** tool lets you replace the foreground color in your image with the background color.

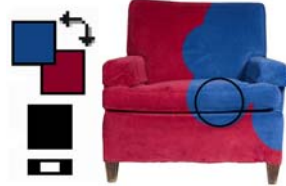

Interactive/Transparency tools



The **Drop shadow** tool lets you add shadows to objects.



The **Object transparency** tool lets you make the colors of an object fade gradually toward the image background color.

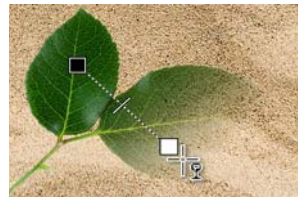

The **Color transparency** tool lets you make specific pixels in an object transparent, based on their color value.



The **Object transparency brush** tool lets you brush areas on an object to make them more transparent.



Image slicing tool



The **Image slicing** tool lets you cut a large image into smaller sections for use on the Web.



Color control area

The **foreground color** is the color that you apply to an image or text by using the brush tools. The **background color** is the color that appears when you erase portions of the background or increase the paper size. The **fill color** is the color that you apply by using the shape and fill tools.



The **Swap color** arrow lets you switch the foreground and background colors.

You can change the foreground, background, or fill color by double-clicking the respective color swatch.

The **Reset color** icon lets you return to the default colors: black as the foreground and fill color, and white as the background color.

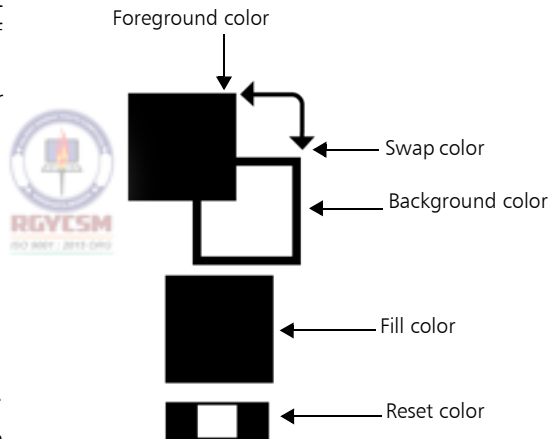

For more information about workspace components, see “Corel PHOTO-PAINT workspace tour” in the Help.

Acquiring images

You can acquire photos from your digital camera by connecting your camera or a media card reader to your computer and using one of the following methods:



- If your digital camera or card reader appears as a drive on your computer, you can copy images directly to a folder on your hard disk, and then open them in Corel PHOTO-PAINT.
- You can load images directly into Corel PHOTO-PAINT by using Windows Image Acquisition (WIA) or the TWAIN driver of your digital camera. WIA is a standard interface and driver for loading images from peripheral devices, such as scanners and digital cameras.
- You can use the software provided with your digital camera to save the images to your computer, and then open the images in Corel PHOTO-PAINT. For more information, see the documentation that was provided with your digital camera.

You can scan images and pages into Corel PHOTO-PAINT by using WIA, the TWAIN driver, or your scanner software. Sometimes, scanned images contain lines, moiré (a wave pattern), or noise (speckled effect). You can remove these defects by using special effects filters. For more information, see “Retouching” on page 60.

For more information, see “Acquiring images from scanners and digital cameras” in the Help.

Cropping and rotating

Cropping lets you remove unwanted areas from images to improve their composition.

 To crop an image, click the **Crop** tool  in the toolbox, and drag in the image window.



The selected area indicates the portion of the image that will remain. The area outside the selection will be cropped.

Often, you may need to rotate an image to change its orientation to portrait or landscape.

 To rotate an image, click **Image ▶ Rotate**, and click a menu command.



*Top: The image has been selected for rotation.
Bottom: The image has been rotated.*

If you need to straighten photos that were taken or scanned at an angle, you can use the **Straighten image** dialog box (**Adjust ▶ Straighten image**).

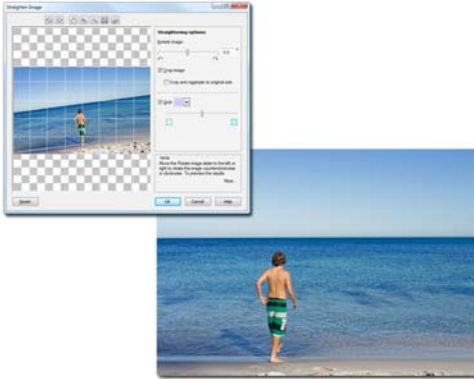

Top: The **Straighten image** dialog box displays a crooked image. Bottom: The image has been straightened.

Changing image size and resolution

The term “image size” often refers to the pixel dimensions — that is, to the image’s height and width expressed in pixels. Image resolution refers to the number of pixels per inch (ppi) within an image. The pixels-per-inch measurement corresponds to dots per inch (dpi) in discussions of printing or scanning. Note that the image size in pixels differs from file size, which is measured in kilobytes (KB), megabytes (MB), or gigabytes (GB).

Image resolution determines how sharp and detailed an image is when it is displayed on a monitor or printed. The resolution you choose depends on how the image is output. Typically, images that are created for display on computer monitors or for the Web are 96 or 72 dpi. Images that are intended to be printed

on desktop printers are usually 150 dpi, whereas professionally printed images are usually 300 dpi or higher.



Resolution of 72 dpi (left) and 300 dpi (right)

The image size (pixel dimensions) and resolution determine the amount of image data in a file. The more pixels an image contains, the higher its quality. However, a larger image produces a larger file. Often, you must adjust the image size or resolution to optimize image quality while keeping the file size manageable.

Increasing image resolution for print

Images that are intended for print need to have a high image resolution. To prepare a photo taken with a digital camera for print, you need to maintain the original file size (the number of pixels) and increase the resolution (the number of pixels per inch) to at least 300 dpi. This method decreases the width and height of the image and creates a better printed result. Alternatively, you can specify a smaller width and height, which automatically increases the resolution values.

 You can increase the image resolution in the **Resample** dialog box (**Image ▶ Resample**).

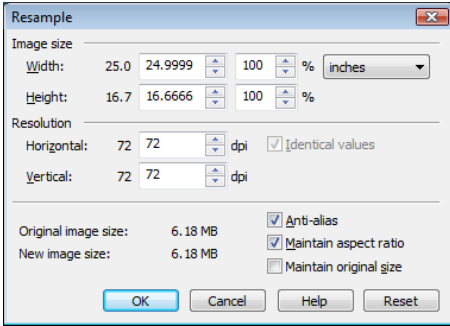

The **Resample** dialog box (top) shows that the photo (bottom) has a resolution of 72 dpi, which is too low for print.

accomplish this by resampling, a process that changes the image resolution. Resampling (also called downsampling or upsampling) often causes blurring, but you can counteract this effect by applying the **Unsharp mask** filter (**Effects** ▶ **Sharpen** ▶ **Unsharp mask**) to the resampled image.

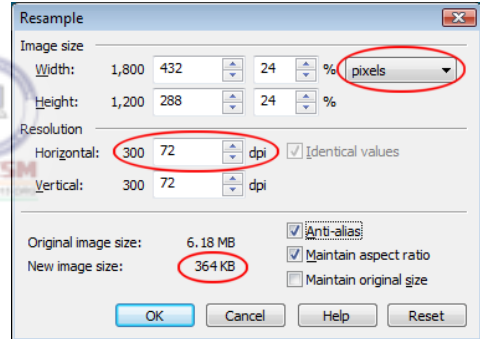
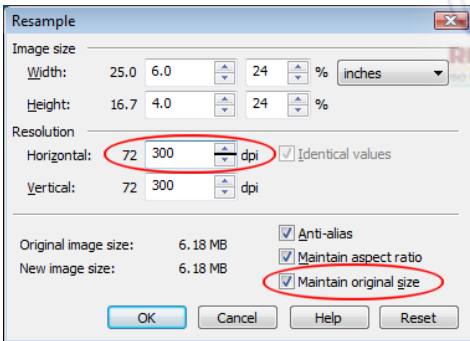
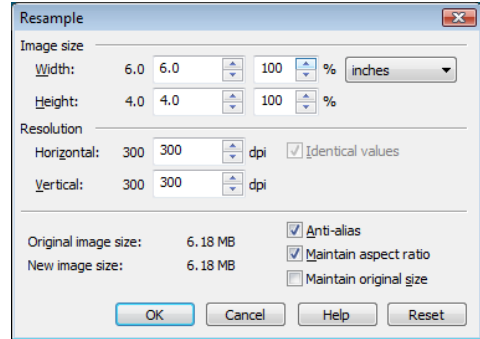

To increase the image resolution for print, the **Maintain original size** check box is enabled first. Next, the resolution is increased to 300 dpi, and the width and height of the image are automatically adjusted.

Top: The **Resample** dialog box shows that a photo is not suitable for Web use. Bottom: To prepare the photo for the Web, the unit of measure is changed to pixels. Then, the image resolution is decreased to 72 dpi, which automatically decreases the width and height of the image, along with the file size.

Reducing file size and image dimensions

If you want to use an image on a Web page, you need to reduce its file size. You can

The photo that you are preparing for the Web may require specific width or height in pixels. You can specify the exact dimensions you need in the **Resample** dialog box. When you specify these settings, the image resolution and the file size are automatically adjusted.

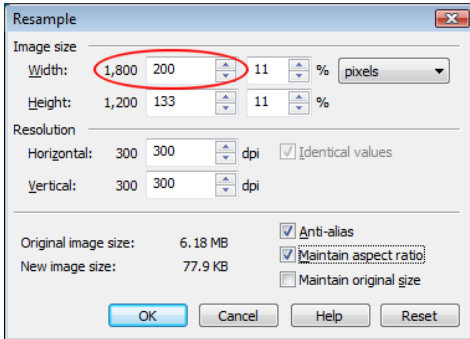

In this example, the width of a photo is decreased from 1,800 pixels to 200. The height of the photo is automatically decreased in proportion to the width because the **Maintain aspect ratio** check box is enabled.

Tips on resizing images

- Avoid increasing the image size by more than 125%. Otherwise, images may appear stretched and pixelated.
- Resize an image after you have retouched and corrected it.
- Resize an image after you have cropped unwanted areas. Decreasing the image size after cropping ensures that the image has as much useful information as possible.
- The size of the image on your screen depends on the pixel height and width of the image, on the zoom level, and on your monitor settings. As a result, an image that is displayed on your monitor may differ in size from a printed version.

For more information about changing the image size and resolution, see “Changing image dimensions, resolution, and paper size” in the Help.

Changing color modes

A color mode defines the number and kind of colors that make up an image. Black and white, grayscale, RGB, CMYK, and paletted are examples of color modes. You can convert images to different color modes, depending on their intended use. For example, the CMYK color mode is recommended for images to be sent for commercial printing. The RGB color mode is best for Web photos, and the paletted color mode is best for GIF images.

Whenever you convert an image, you may lose color information. For this reason, you should finish editing and then save a copy of the image before converting the image to a new color mode. For more information, see “Changing color modes” in the Help.



To convert an image to a different color mode, click **Image**, and then click a **Convert to** command.

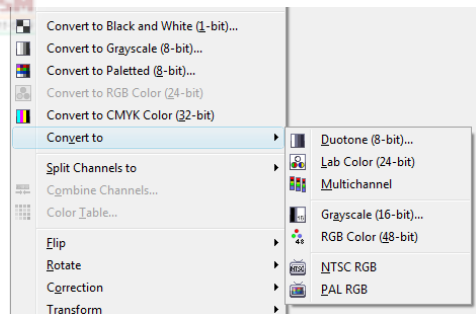

Available **Convert to** commands

Retouching

With Corel PHOTO-PAINT, you can fix common problems in digital photos and scanned images by using tools and special effect filters.

One common problem in photos is red-eye, which occurs when light from a flash reflects off the back of a person's eye.

 To remove red-eye, start by zooming in on the eye. Then, click the **Red-eye removal** tool, adjust the brush size to match the size of the eye, and click the eye.



The **Red-eye removal** tool has been used on the photo subject to correct the right eye and select the left eye.

Dust and scratch marks are another common problem in images. You can remove dust and scratch marks by applying a filter to the entire image. If an image has one or more scratches in a specific area, you can create a mask around the scratches and apply the filter to the editable area.

 To remove dust and scratch marks, click **Image ▶ Correction ▶ Dust and scratch**.

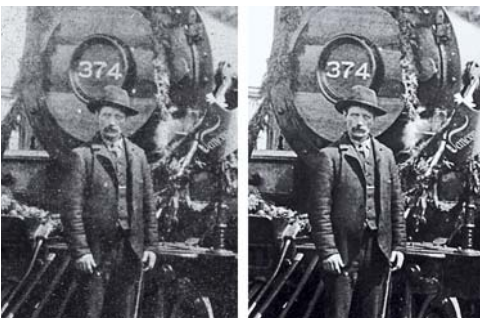

Left: The dust marks reduce image quality. Right: Dust marks have been removed in the retouched image.

If a scratch or blemish is fairly large or is located in an area with varied color and texture (such as leaves on a tree), you can achieve better results by cloning image areas. When you clone, you copy pixels from one image area to another.

 To clone image areas, click the **Clone** tool, and choose **Clone** from the **Brush category: Clone** picker on the property bar. Next, click to set the source point, and drag where you want to apply the pixels from the source point. To reset the source point, right-click the area that you want to clone.

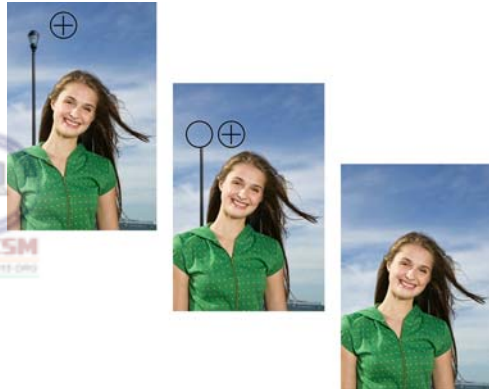

Left: The source point is set to clone areas of the sky. Middle: Cloned sky areas are copied on top of the post. Right: Retouched image.

If you use a soft-edge brush and a greater transparency value, the cloned areas blend seamlessly in the image.

Photos from digital cameras may often contain specks of random colors, which are collectively referred to as "noise." These specks are caused by poor lighting conditions or limitations of the camera sensor. You can remove noise from digital photos or scanned images by clicking **Effects ▶ Noise ▶ Remove noise**.

 To remove noise and artifacts from photos in the JPEG format, click **Effects ▶ Blur ▶ Smart blur**.



Left: Noise appears as mottled colors and interferes with the photo's clarity. Right: The noise has been removed to reveal a clearer picture.

In addition to noise, scanned images may contain lines or moiré (a wave pattern).

 To remove lines from a scanned image, click **Image ▶ Transform ▶ Deinterlace**.

To remove moiré, click **Effects ▶ Noise ▶ Remove moiré**.



Left: The image contains moiré, which appears as a wavy grid of discolored lines. Right: The moiré has been removed.

For more information, see “Retouching” in the Help.

Adjusting color and tone

When you need to adjust the color and tone of photos, the Image Adjustment Lab (**Adjust ▶ Image Adjustment Lab**) should be your first stop. It lets you brighten or darken a photo, improve the contrast, reveal image detail, and correct washed-out colors. You can experiment with different settings and capture them in snapshots, so that you can compare different versions and choose the best result. For more information, see “Adjusting color and tone” in the Help.

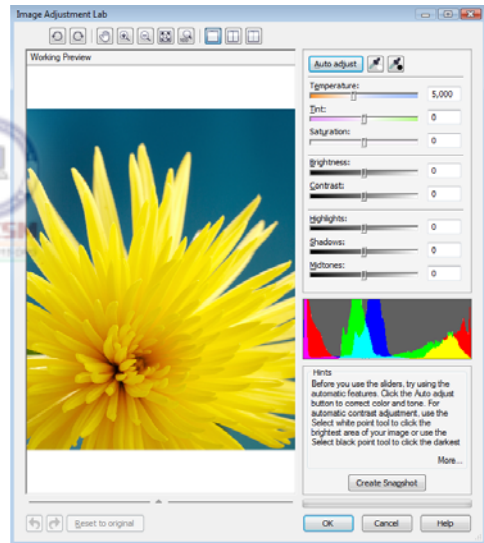

Image Adjustment Lab

Some common color corrections are described and illustrated in the following table.

Color correction**Before****After**

You can correct photos that have an overall color cast, in which the photo appears to be tinted with one color. Note the blue color cast in the Before photo. The blue cast has been corrected in the After photo.



You can increase the color saturation for photos that contain dull colors. In the Before photo, the colors are muted. In the After photo, the color saturation has been increased to create more vivid colors.



If a photo contains dark shadows that obscure the photo subjects, you can brighten the photo by lightening the shadows. In the Before photo, shadows darken both the grass and photo subjects. In the After photo, the shadows have been lightened to make the subjects more visible.



Working with masks

A mask is used in image editing to isolate a particular area (the editable area) without affecting the remaining part (the protected area). Editable areas are sometimes called “selections” in other applications.

You can display a mask overlay that appears only over protected areas to make it easy to differentiate between protected and editable areas. The border separating an editable area and its corresponding protected area is indicated by a dashed outline, called the mask marquee. You can display the mask marquee only when the mask overlay is hidden.



Left: Mask overlay. Right: Mask marquee.

You can define editable areas by using the mask tools in the toolbox.

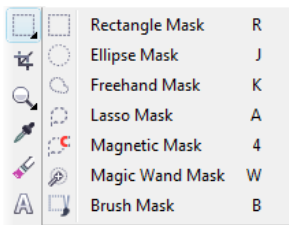

Mask tools

After defining an editable area, you may want to adjust the area’s shape and position. If you want to subtract from or add to an editable area, you can access mask modes from the property bar when a mask tool is active.



Left: The editable area includes a part of the wing.
Middle: The remaining part of the wing is added to the editable area, along with some blue background.
Right: The blue background is removed from the editable area.

In addition, you can adjust the edges of an editable area so that it blends smoothly into the protected areas. For more information, see “Adjusting the edges of editable areas” in the Help.

You can invert a mask so that the protected area becomes editable and the editable area becomes protected. For example, if you want to edit a photo subject that is set against a plain background, the easiest method is to select the background and then invert the mask, as shown in the following illustration.



Left: The **Magic wand mask** tool is used to select the background. Right: The mask is inverted to select the butterfly.

For more information about masks, see “Working with masks” in the Help.

Working with objects and lenses

Objects are transparent layers that float above the background and stack on top of one another. For example, when you open a photo, it becomes the background. Any new objects are stacked above the background as they are created.

Using objects offers many advantages. Objects can be repositioned, resized, rotated, and edited without affecting other objects or the background. In addition, you can place an object behind or in front of other objects, and you can use merge modes to control how an object blends with the underlying objects or background.

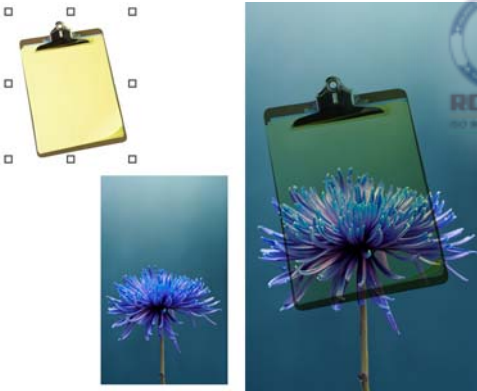

Left: The **Multiply** merge mode is used to blend two objects. Right: Blended image.

To create objects from brushstrokes and shapes, click **Object ▶ Create ▶ New object**, and paint or draw in the image window.

To create an object from an editable area, click **Object ▶ Create ▶ Object: copy selection**.

To create an object from the background, click **Object ▶ Create ▶ Create from background**.

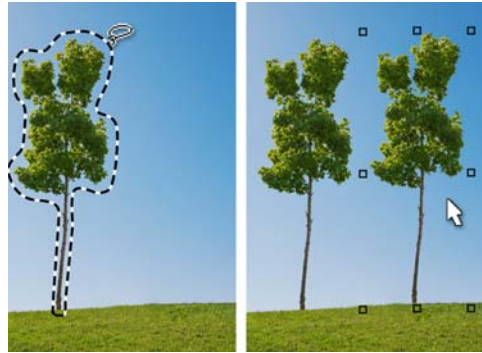

An editable area is selected and copied (left) to create a new object (right).

Lenses, which are also known as “adjustment layers,” are special objects that let you preview special effects and image adjustments without permanently altering the image pixels.

To create a lens that covers an entire image or the editable area of a mask, click **Object ▶ Create ▶ New lens**.

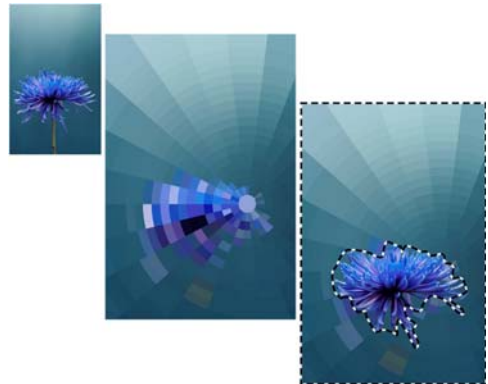

Left: Original image. Middle: A lens is applied to the entire image. Right: A lens is applied to an editable area.

You can apply multiple lenses to view the effect of applying multiple image adjustments.

The **Object pick** tool and the **Objects** docker can help you select, transform, and organize objects and lenses in an image.

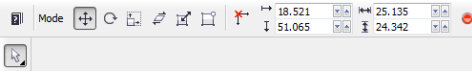

Object pick tool and property bar controls

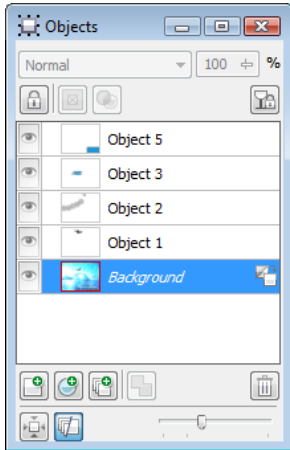

Objects docker

open in the image window in the original file format.

To prepare an image for printing, you can save or export to the TIFF file format. To prepare an image for the Web, you can export it to JPEG, PNG, or GIF. The JPEG and PNG file formats are ideal for photos, which usually contain color gradations. The GIF file format is suitable for images that contain solid colors.

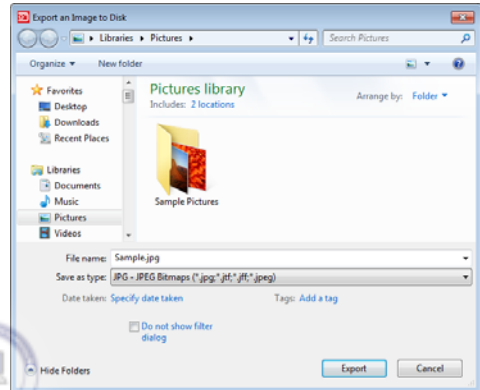

Export dialog box

Sharing your work

To share your images with others, you can save or export them to other file formats (such as TIFF, JPEG, or PDF), print them, or upload them to ConceptShare. Regardless of how you intend to use an image, it is a good idea to keep a copy of the file in the Corel PHOTO-PAINT (CPT) file format. Saving to the CPT file format retains all image properties: objects, the most recently created mask, alpha channels, grids, guidelines, and color information.

To change the file format of an image, you can save it (**File ▶ Save as**) or export it (**File ▶ Export**) to a different file format. When you use the **Save as** command, the image appears in the image window in the new file format. When you export an image, the image remains

You can also quickly save an image to a PDF file by clicking **File ▶ Publish to PDF**. The **Publish to PDF** dialog box lets you access PDF presets that optimize the PDF file for its intended use — for example, **Document distribution**, **Prepress**, or **Web**.

Corel PHOTO-PAINT provides extensive options for printing your work. The **Print** dialog box (**File ▶ Print**) lets you specify the layout and scale of a print job, preview print jobs, and set various prepress options, such as whether to print crop marks and registration marks. In addition, you can view a summary of issues and problems, along with suggestions for resolving them. For more information, see the “Printing” section of the Help.

With ConceptShare (**File ▶ Publish image to ConceptShare**), you can publish an image to

a Web-based environment to share designs and ideas with clients and co-workers. For more information, see “Collaborating” in the Help.

Setting preferences

In Corel PHOTO-PAINT, you can change the default workspace settings and other options according to your preferences. You can specify settings such as unit of measure, type of pointer, and default zoom level. In addition, you can specify auto-save settings or set display options to choose the color of paths,

mask tints, guidelines, and transparency grid patterns.

 To set preferences, click **Tools ▶ Options**.

To restore the default workspace settings and options at any time, restart Corel PHOTO-PAINT while holding down **F8**.

For more information about setting preferences, see “Setting options” in the Help.

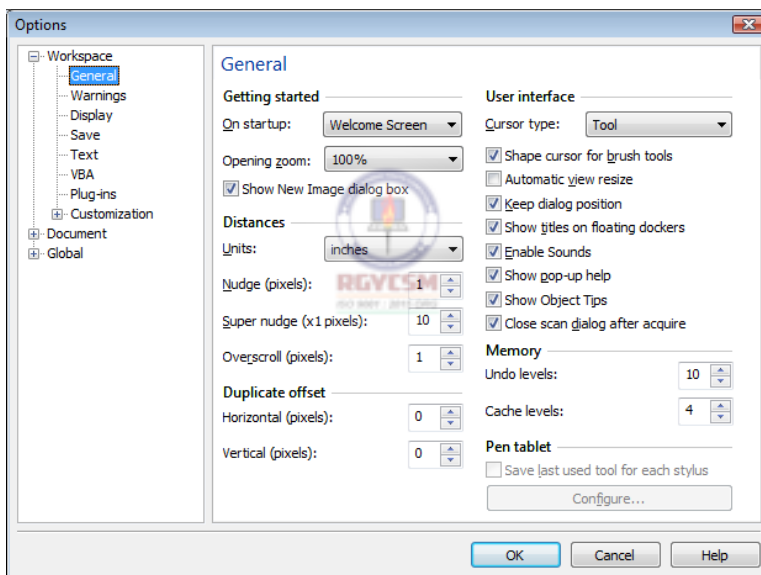

General page of the Options dialog box





mAt Work

Image created by
Om Prakash Thapa
India

Part Three

Color, Type, and Styles





Chapter 6: Color Basics

How are colors defined? **72**

Choosing a color mode **75**

Using process and spot colors **76**

Choosing colors **77**

Working with color styles and harmonies **81**

Using the Document palette, Color Styles palette, and Image palette **84**

Displaying and organizing color palettes **86**

Creating custom palettes **88**

Chapter 6: Color Basics

In CorelDRAW or Corel PHOTO-PAINT, choosing color is a critical part of your workflow. Color is an important design element because it helps you set a tone or convey a specific meaning.

This chapter introduces you to the different methods of choosing and using color in CorelDRAW and Corel PHOTO-PAINT.

How are colors defined?

Color is literally in the eye of the beholder. The sensation of color is a result of the human eye's response to light and the nervous system's interpretation of that response.



Color perception depends on the eye's response to light.

Through the use of color models, this complex process has been defined mathematically. The color models allow software applications (such

as CorelDRAW and Corel PHOTO-PAINT) and digital devices (such as computers, monitors, digital cameras, and printers) to store, manipulate, and accurately reproduce color.

Color models, such as Lab, RGB, CMYK, and HSB, provide a systematic way of organizing and reproducing a broad range of colors from a small set of primary colors. Each color is defined numerically. The numeric values allow the colors to be interpreted, communicated, and reproduced by a wide range of devices and applications.

Each color model has a unique way of defining colors numerically.



Lab color model

The Lab color model was developed by the Commission Internationale de l'Eclairage (CIE). Unlike the RGB and CMYK color models, the Lab color model is based on how the human eye perceives color, rather than on how monitors, printers, digital cameras, and other devices reproduce color. For this reason, Lab is known as a device-independent color model. RGB and CMYK are considered device-dependent color models, because the same colors appear different when they are printed or displayed on different devices.

In the Lab color model, the range (or gamut) of all visible colors is represented as a horseshoe-

shaped figure. This figure is often used as a reference for comparing the range of colors that other color models can produce. Lab is also used in color management as a reference for converting colors from one color space to another.



Lab color model

RGB color model

The RGB color model uses the components red (R), green (G), and blue (B) to define the amounts of red, green, and blue light in a given color. In a 24-bit image, each component is expressed as a number from 0 to 255. In an image with a higher bit rate, such as a 48-bit image, the value range is greater. The combination of these components defines a single color.

In additive color models, such as RGB, color is produced from transmitted light. RGB is therefore used on monitors, where red, blue, and green lights are blended in various ways to reproduce a wide range of colors. When red, blue, and green lights are combined at their maximum intensities, the eye perceives the

resulting color as white. In theory, the colors are still red, green and blue, but the pixels on a monitor are too close together for the eye to differentiate the three colors. When the value of each component is 0, which signifies an absence of light, the eye perceives the color as black.

RGB is the most commonly used color model, because it allows a broad range of colors to be stored and displayed.

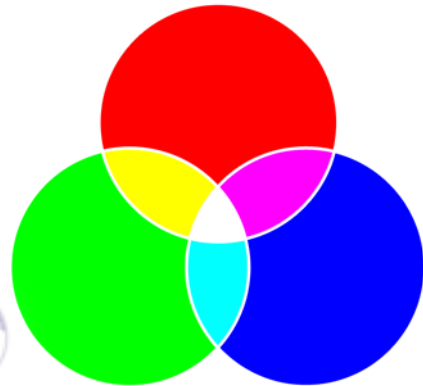

RGB color model. White is the result of combining the three RGB colors at their maximum intensities.

CMYK color model

The CMYK color model, which is used in printing, uses the components cyan (C), magenta (M), yellow (Y), and black (K) to define color. Values for these components range from 0 to 100 and represent percentages.

In subtractive color models, such as CMYK, color (that is, ink) is added to a surface, such as white paper. The color then “subtracts” brightness from the surface. When the value of each color component (C,M,Y) is 100, the

resulting color is black. When the value of each component is 0, no color is added to the surface, so the surface itself is revealed — in this case, the white paper. Black (K) is included in the color model for printing purposes because black ink is more neutral and darker than blending equal amounts of C, M, and Y. Black ink produces sharper results, especially for printed text. In addition, black ink is usually less expensive than using colored ink.

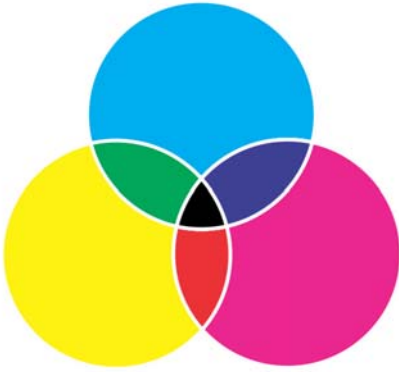

CMYK color model. Black is the result of combining the three CMY colors at their maximum intensities.

HSB color model

The HSB color model uses hue (H), saturation (S), and brightness (B) as components for defining color. HSB is also known as HSV (with the components hue, saturation, and value). Hue describes the pigment of a color and is expressed in degrees to represent the location on the standard color wheel. For example, red is 0 degrees, yellow is 60 degrees, green is 120 degrees, cyan is 180 degrees, blue is 240 degrees, and magenta is 300 degrees. Saturation describes the vividness or dullness of a color. Values of saturation range from 0 to 100 and represent percentages (the higher the value, the more vivid the color). Brightness

describes the amount of white in the color. Like saturation values, brightness values range from 0 to 100 and represent percentages (the higher the value, the brighter the color).



HSB color model

Grayscale color model

The grayscale color model defines color by using only one component, lightness, which is expressed in values that range from 0 to 255 in 8-bit images. The value range varies, depending on the bit rate of the image. Each grayscale color has equal values of the red, green, and blue components of the RGB color model.

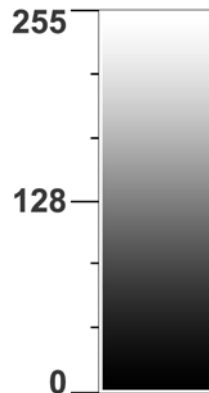

Grayscale color model

Choosing a color mode

When you create a new CorelDRAW document or Corel PHOTO-PAINT image, you must choose a color mode, preferably based on the color model that corresponds to the project's destination. The color mode determines the colors to be used in the application. For example, if you know that the intended destination for your project is the Web, you can choose the RGB color mode. By choosing the correct color mode when you start a project, you can take some of the guesswork out of choosing colors. As a result, the colors in your projects will be reproduced more accurately.



The CMYK color mode is recommended for printed material, while the RGB color mode is recommended for material that will be viewed online.

If you don't know your project's ultimate destination, or if your project will be both printed and viewed online, you should choose the RGB color mode. This color mode lets you store a broad range of colors and can be easily converted to CMYK for printing.

Choosing a color mode for a CorelDRAW document

In CorelDRAW, the primary color mode determines the colors in the default color

palette, which lets you find suitable colors more easily. The primary color mode is used as the default color mode when you export a document as a bitmap or in the Adobe Illustrator (AI) file format. For example, if you set the RGB color mode as your primary color mode and export a document as a JPEG, the color mode is automatically set to RGB.

 To specify the color mode for a new CorelDRAW document, choose an item from the **Primary color mode** list box in the **Create a new document** dialog box.

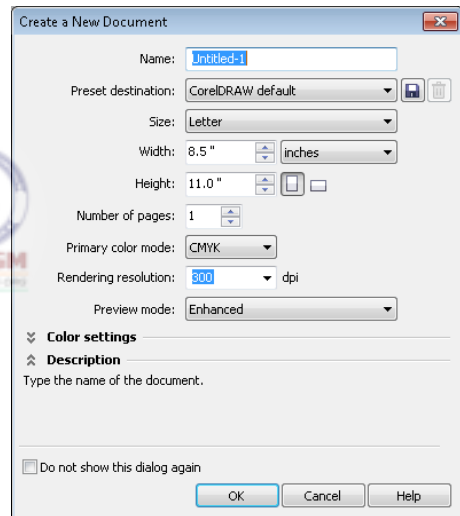

The primary color mode is set to CMYK for a new CorelDRAW document.

The CorelDRAW primary color mode does not restrict the type of colors that you can apply to a drawing. For example, if you set the color mode to RGB, you can still apply, and accurately display, colors from a CMYK color palette in the document.

Choosing a color mode for a Corel PHOTO-PAINT image

In Corel PHOTO-PAINT, the color mode that you choose for a new image determines the default color palette. For example, if you choose the RGB color mode, the default color palette displays only RGB colors, which makes it easy to choose and apply the correct colors.

To specify the color mode for a new Corel PHOTO-PAINT image, choose an item from the **Color mode** list box in the **Create a new image** dialog box.

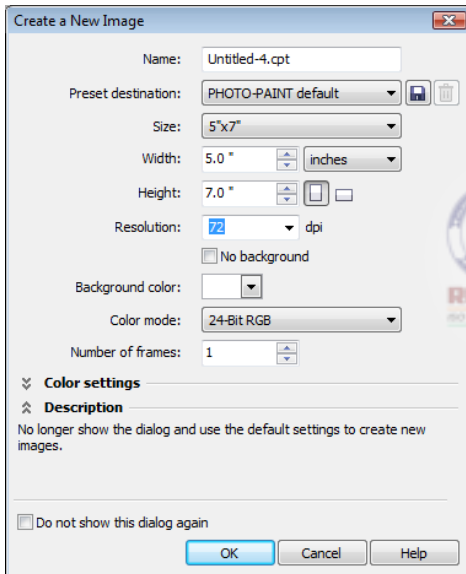

The color mode is set to 24-Bit RGB for a new Corel PHOTO-PAINT image.

Unlike the primary color mode in CorelDRAW, the color mode in Corel PHOTO-PAINT determines and limits the colors that you can apply to an image. For example, if you choose the RGB color mode, you can apply only RGB colors to the image. When you choose a color from another palette, such as CMYK, the color

is converted to RGB when it is applied to the image. If you tag a specific channel with a spot color, you can apply the spot color to the channel. However, if you apply a spot color to the image background, the color is converted to the RGB color mode.

Using process and spot colors

When you send a document to a print service provider, you can specify either process color or spot color as the method of color printing. The primary difference between these two methods is the number of inks, or separations, that are required to reproduce colors.

Process colors

A typical project may contain hundreds of colors, but you do not need hundreds of color separations when you print it. Only four inks (cyan, magenta, yellow, and black) are needed to print full-color documents. The colors that are produced by mixing these four standard printing inks are known as process colors. By choosing colors from any of the color palettes in CorelDRAW Graphics Suite X6, you can use process colors in your projects.



Cyan (C), magenta (M), yellow (Y), and black (K) color separations are used to reproduce full-color images.

Spot colors

Often, spot colors are custom premixed inks that require separate printing plates. Spot colors are often used in addition to process colors. For example, you can add a spot color to a CMYK project if that color cannot be reproduced by using CMYK values.

You can choose a spot color from any of the spot-color palettes that appear in the **Palette libraries** folder of the **Color palette manager** docker. Examples of these spot-color palettes are PANTONE®, HKS®, and TOYO.

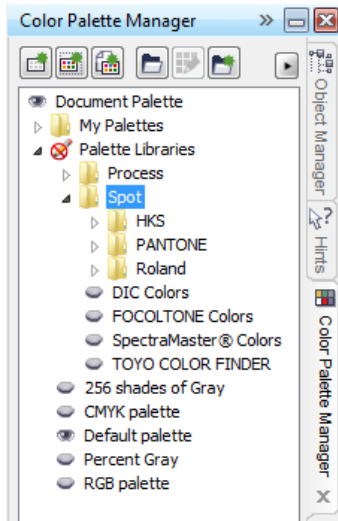

The spot-color palettes are stored in the **Spot** folder of the **Color palette manager** docker.

Tips on using process and spot colors

If you need help in deciding how to use spot colors and process colors in your project, consider the following:

- To minimize printing costs, use process colors for projects that contain multiple colors, and spot colors for projects that contain very few colors.

- If you need to print a specific color accurately (for example, the color of a corporate logo in a brochure), use a spot color instead of a process color.
- Remember that although you can define process colors by using RGB values, the printed output will use CMYK inks. Because the colors are converted from RGB to CMYK before ink is applied to the paper, a shift in color may result.

Choosing colors

CorelDRAW and Corel PHOTO-PAINT provide various tools and features to help you choose the best colors for your projects. You can choose colors from any of the palettes, viewers, harmonies, and eyedropper tools that are available with the following workspace components:



- color palettes
- **Object properties** docker (CorelDRAW)
- **Color styles** docker (CorelDRAW)
- **Uniform fill** dialog box
- **Color** docker
- **Color eyedropper** tool (CorelDRAW)
- **Eyedropper** tool (Corel PHOTO-PAINT)

Color palettes

The default color palette in CorelDRAW or Corel PHOTO-PAINT provides 99 color swatches that are based on the color mode of your document or image. Each color swatch in turn provides numerous shades and tones from which to choose.

-  To fill an object with color in CorelDRAW, select the object, and click a color on the color palette.

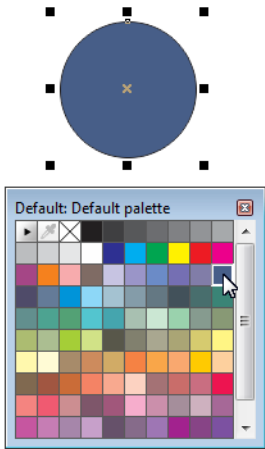

Clicking the blue color swatch on the color palette fills the circle with blue.

To change the outline color of an object in CorelDRAW, right-click any color on the color palette.

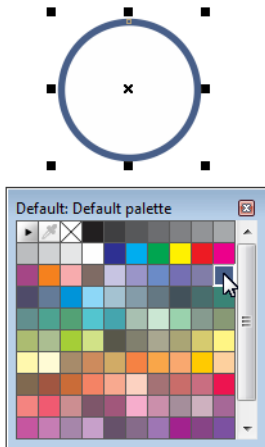

Right-clicking the blue color swatch on the color palette changes the circle's outline color to blue.

To change the foreground color in Corel PHOTO-PAINT, click a color on the color palette.

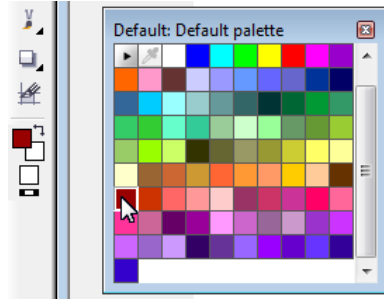

Clicking the red color swatch on the color palette changes the **Foreground color** switch to red.

To change the fill color in Corel PHOTO-PAINT, right-click a color on the color palette.

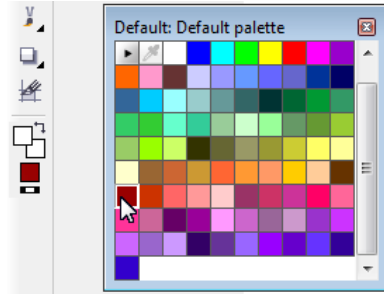

Right-clicking the red color swatch on the color palette changes the **Fill** color switch to red.

To access different shades of a color, hold down a color swatch until a pop-up color palette appears.

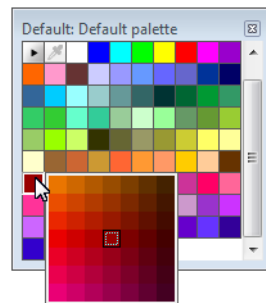

Holding down the red color swatch displays various shades of red in a pop-up color palette.

Object Properties docker

The **Object properties** docker (**Window ▶ Dockers ▶ Object properties**) in CorelDRAW allows you to define object properties, including outlines and fills. It lets you pick an outline or fill color from the standard color picker, or create a custom color using color models, mixers, and additional palettes available in the **Select color** dialog box.

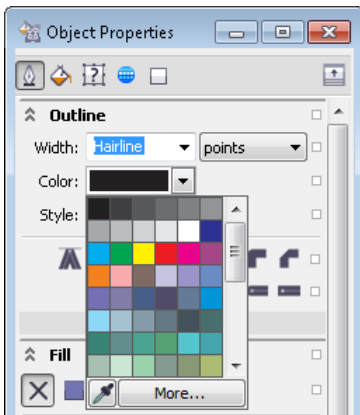

The color pickers in the **Object properties** docker allow you to choose a color or create a custom color for an object fill and outline.

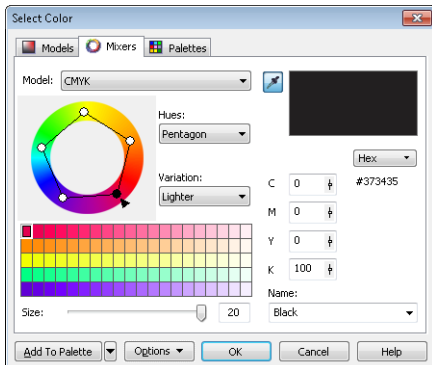

Mixers page of the **Select color** dialog box

To display the **Select color** dialog box in CorelDRAW, open the color picker in the **Outline**, **Fill**, or **Character** section of the **Object properties** docker, and click **More**.

Color Styles docker

The **Color styles** docker lets you create, apply, and edit color styles. When you apply a color style to multiple objects, you can simultaneously update all the objects by modifying the color style. The **Color styles** docker also lets you organize color styles in groups called harmonies. A harmony allows you to link color styles in a specific relationship, so that when you edit one style in the harmony, the other styles get updated without changing the color relationship. Use this feature to preview a drawing in different color schemes or modify the entire color composition in one step. For more information about using color styles and harmonies, see “Working with color styles and harmonies” on page 81.

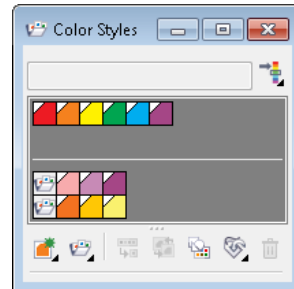

The top section of the styles list includes individual color styles, while the bottom section contains color harmony folders.

To apply a color style in CorelDRAW, select an object by using the **Pick** tool , and in the **Color styles** docker, double-click a

color style to apply a fill, or right-click a color style to apply an outline.

Uniform Fill dialog box

The **Uniform fill** dialog box gives you access to additional color palettes and lets you use various methods for choosing and editing colors. For example, you can use color viewers or color mixers to specify the color you want.

 To display the **Uniform fill** dialog box in CorelDRAW, click the **Fill** tool in the toolbox, and click **Uniform fill**.

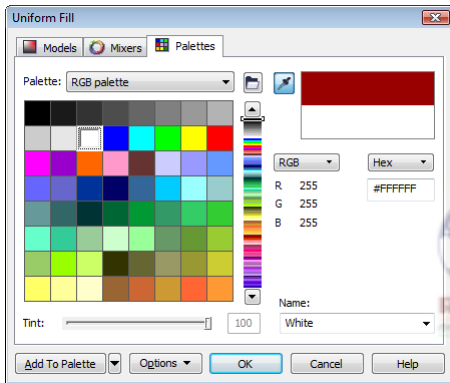

Uniform fill dialog box

Color docker

The **Color docker** provides the same variety of color mixers, viewers, and palettes that are already available in the **Uniform fill** dialog box as well as some additional controls, such as color sliders. It also has one advantage over the **Uniform fill** dialog box: You can keep it open at all times.

 To display the **Color docker**, click **Window** ► **Dockers** ► **Color**.

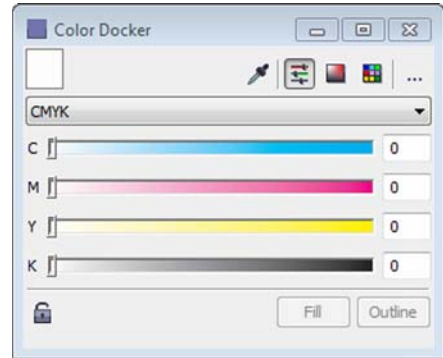

Color docker

Eyedropper tools

Eyedropper tools let you quickly choose a color from one area of your document or image and apply it to another area. These tools are useful when you want to ensure an exact match with an existing color in your project. You can also use eyedropper tools to match colors from images outside the image or document, outside the application, or on the desktop.

 To choose a color from an item on your desktop, click the **Color eyedropper** tool in the CorelDRAW toolbox, and click **Select from desktop** on the property bar. Then, click a color on your desktop.

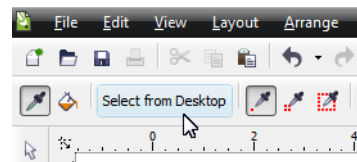

*Clicking **Select from desktop** on the property bar lets you select a color outside CorelDRAW.*

Eyedropper tools are also available for adding colors to color palettes, dockers, and dialog boxes.

 To add a color to the **Document** palette in CorelDRAW, click the eyedropper button on the palette, and click a color in the document window.

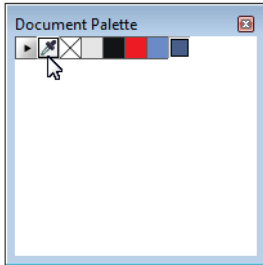

The eyedropper button on the **Document** palette

 To add a color to the **Uniform fill** dialog box in Corel PHOTO-PAINT, click the **Fill** tool. On the property bar, click the **Uniform** button for the **Fill** control, and click the **Edit fill** button. Then, click the **Eyedropper** button in the dialog box, and click a color in the image window.

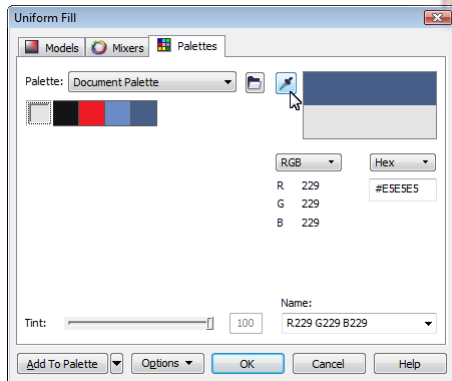

The eyedropper button in the **Uniform fill** dialog box

Working with color styles and harmonies

A color style is a color that you save and apply to objects in your CorelDRAW document. A color style is reusable, and any time you update

it, all objects that use this style are automatically updated. Because an infinite number of colors are available in CorelDRAW, color styles can make it easier to apply the exact color you want.

You can create a color style from an existing object or from scratch. When you create a color style, it is saved to the active drawing and to the **Color styles** palette.

 To create a color style, drag a swatch from any open palette, or drag an object from the document window, to the top gray area of the **Color styles** docker.

When you create a color style, you can edit it in the **Color editor** by using a variety of controls, such as color sliders, mixers, and custom palettes. Most of these controls are also available in the **Select color** and **Uniform fill** dialog boxes, and the **Color** docker.

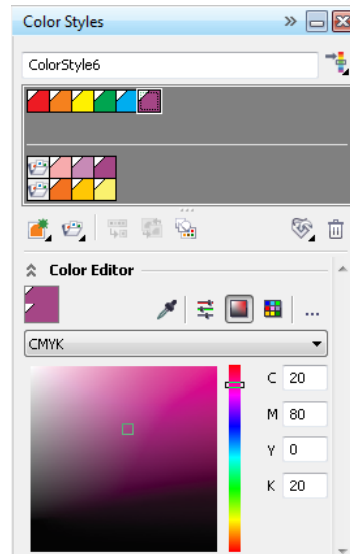

Select a color style in the color styles list, and edit its properties in the **Color editor**. You can distinguish a color style from a regular color by the white triangle in the upper-left corner of the color swatch.

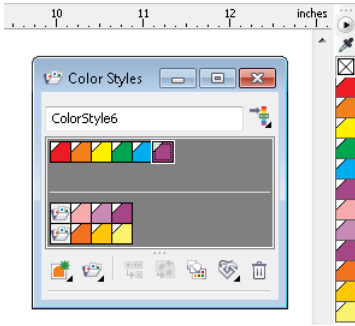

When you create a color style in the **Color styles** docker (left), it is automatically added to the **Color styles** palette (right). The **Color styles** palette is not open by default.

You can select all color styles that are not used in a document. You can also convert color styles to different color modes or to spot colors to prepare your document for production printing.

To select all color styles that are not used in a document, click the **Select unused** button  in the **Color styles** docker.

Color styles can be combined into groups called harmonies. A harmony allows you to link color styles into hue-based relationships and modify them together as a set. By editing color styles in a harmony, you can quickly create a variety of alternate color schemes by shifting the colors together, or you can alter the color composition of your artwork in one step.



Color styles grouped in a harmony

You can create a color harmony from scratch or from the colors of an existing object.

To create a color harmony from scratch, click the **New color harmony** button , and choose **New color harmony**. Then, drag color swatches from any open palette to the harmony folder in the **Color styles** docker.

To create a color harmony from an existing object, drag the object to the bottom part of the gray area in the **Color styles** docker, and specify options in the **Create color styles** dialog box.



The color harmony was created by dragging the clipart from the document window to the lower section of the color styles list in the **Color styles** docker.

When you edit a harmony, you can change all color styles simultaneously by preserving the relationship between them, or you can modify individual color styles within the harmony.

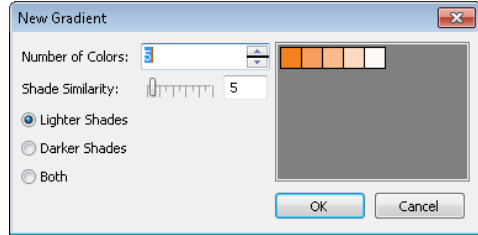



The **New gradient** dialog box allows you to specify the number and type of shades that you want to create from the selected master style.

When you change the hue of the master style in a gradient, you automatically update the related color styles, based on the new hue and the original saturation and brightness values.

Using the **Harmony editor**, you can experiment with different color schemes. By changing one color, you can also find other colors that go well with that color.

CoreDRAW allows you to create a special type of color harmony called a gradient. A gradient consists of a master color style and a number of shades of that color. In most of the available color models and palettes, the derivative styles share the same hue as the master style but have different saturation and brightness levels. In the PANTONE MATCHING SYSTEM® and custom spot color palettes, the master style and the derivative styles are linked to one another but have different tint levels.

 To create a gradient, select a color style in the **Color styles** docker, click the **New color harmony** button , and choose **New gradient**. Specify the settings you want in the **New gradient** dialog box.



After you create a gradient, you can apply it to the design elements in your document.

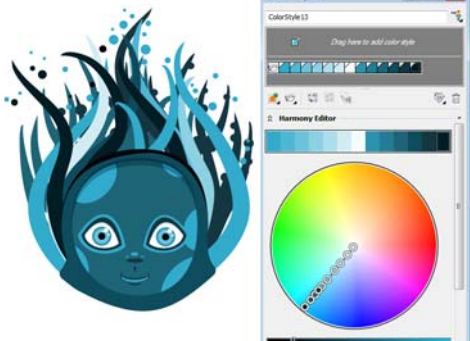

By selecting the gradient folder and dragging any of the selector rings in the **Harmony editor** color wheel, you can see a real-time preview of your drawing in different colors.

Using the Document palette, Color Styles palette, and Image palette

When you start a new document in CorelDRAW, the **Document** palette appears. When you start a new image in Corel PHOTO-PAINT, the **Image** palette appears. These palettes are empty palettes that let you keep track of the colors that you use. By default, they appear docked at the bottom of the application window. The **Color styles** palette is another palette that is created automatically in CorelDRAW when you start a new document, but it is not open by default. It helps you keep track of the color styles that you create.

Adding colors to the Document, Color Styles, or Image palette

Whenever you add a color to your document, the color is automatically added to the **Document** palette or **Image** palette.

Whenever you create a color style in your document, it is added to the **Color styles** palette, but it does not automatically appear in the **Document** palette. You can add the color style to the **Document** palette by applying it to an object in your document, or by manually dragging it from the **Color styles** docker or the **Color styles** palette to the **Document** palette.

To add a color or color style to the **Document** palette in CorelDRAW, select an object, and click a color on the default color palette or double-click a color style on the **Color styles** palette.

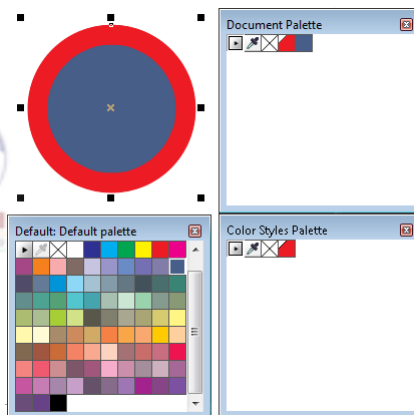

The blue color that was applied to the circle was automatically added to the **Document** palette. The red color style was added to the **Document** palette only after it was applied to the circle outline.

If an image contains a color or a color style that you want to use in the future, you can add it to the **Document**, **Color styles**, or **Image** palette by using the eyedropper button.

To add multiple colors to the **Image** palette in Corel PHOTO-PAINT, click the eyedropper button on the palette, and

while holding down **Ctrl**, click the colors in the image window.

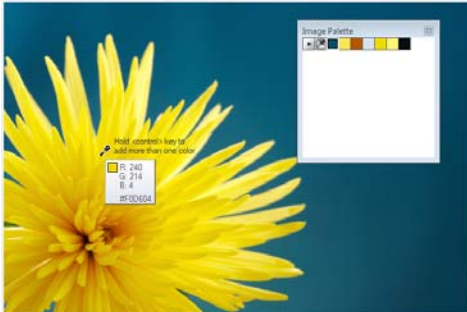

You can quickly add multiple colors to the **Image** palette by using the eyedropper.

To quickly add colors from a bitmap to the **Document** palette in CorelDRAW, drag the bitmap to the **Document** palette.

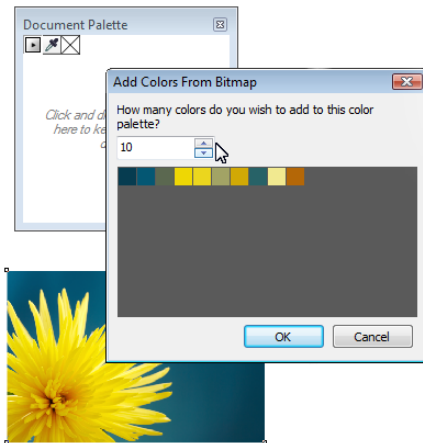

When dragging an image to the **Document** palette, you can choose how many colors are added.

You can also add colors to the **Document**, **Color styles**, or **Image** palette from a color-related dialog box, such as the **Uniform fill** dialog box or the **Select color** dialog box. By moving the colors or color styles to the palette, you can save them for future use.

To add a color or color style to the **Document** or **Color styles** palette in CorelDRAW from the **Uniform fill** dialog box, select an object, and double-click the **Fill color** icon on the status bar. In the **Uniform fill** dialog box, choose a color, click the arrow next to the **Add to palette** button, and choose a palette. Then, click **Add to palette**. The **Color styles** palette is available in the drop-down list after you display it.

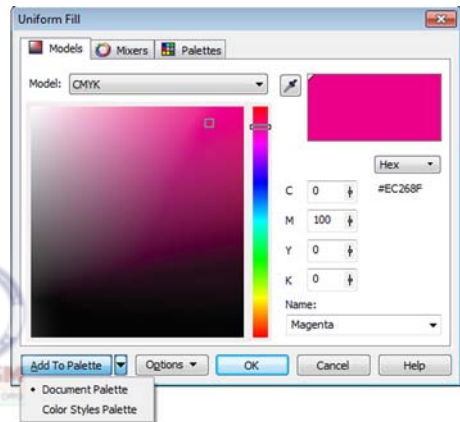

You can add a color to the **Document** or **Color styles** palette from the **Uniform fill** dialog box.

In CorelDRAW, when you open a document that was created with a previous version of the software, only custom spot colors are added to the **Document** palette.

In Corel PHOTO-PAINT, when you open an existing image, such as a photo, no colors are displayed on the **Image** palette.

To add the colors in a photo to the **Image** palette in Corel PHOTO-PAINT, open the file that contains the photo, click the arrow button on the **Image** palette, and click **Add colors from image**.

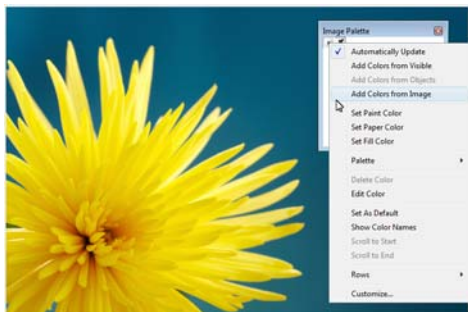

You can quickly add the most dominant colors from an image to the **Image** palette by clicking **Add colors from image**.

In CoreDRAW, you can reset the **Document** or **Color styles** palette so that it does not display colors or color styles that are not used in the document.

To clear the **Document** or **Color styles** palette of colors and color styles that are not used in the current document, click the arrow button, choose **Palette**, and click **Reset palette**.

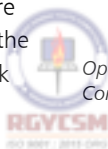

Opening the **Color palette manager** docker in CoreDRAW

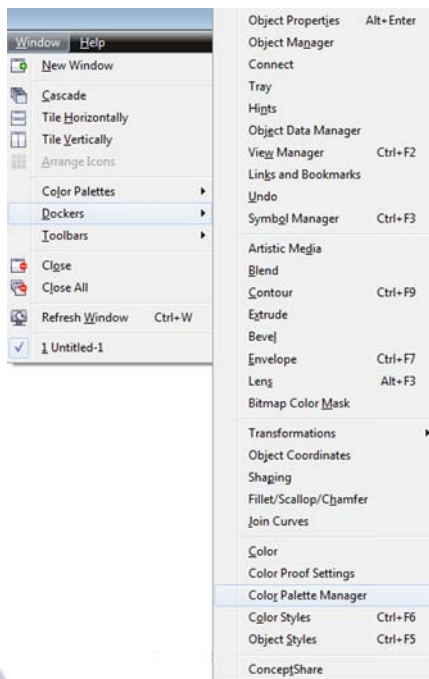

Displaying and organizing color palettes

The **Color palette manager** docker lets you quickly access and display all the available color palettes, including the **Document** and **Color styles** palettes in CoreDRAW or the **Image** palette in Corel PHOTO-PAINT.

To open the **Color palette manager** docker in CoreDRAW, click **Window** ► **Dockers** ► **Color palette manager**.

To open the **Color palette manager** docker in Corel PHOTO-PAINT, click **Window** ► **Color palettes** ► **More palettes**.

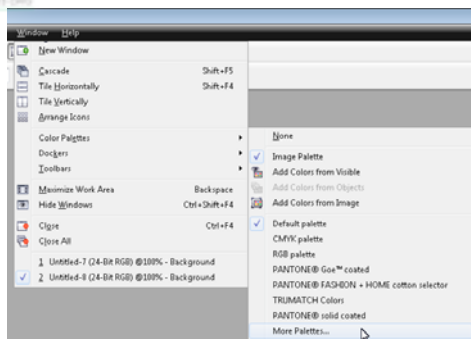

Opening the **Color palette manager** docker in Corel PHOTO-PAINT

To display or hide a color palette in the **Color palette manager** docker in CoreDRAW, click the icon next to the name of the color palette.

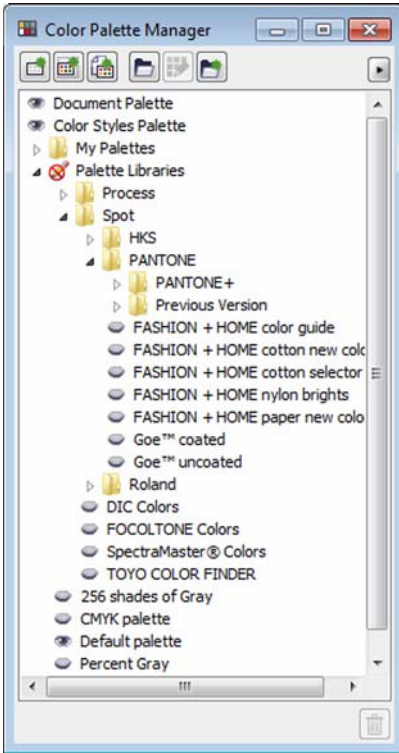

Color palette manager docker

The color palettes in the **Color palette manager** docker are divided into two main folders: **My palettes** and **Palette libraries**.

My Palettes folder

You can use the **My palettes** folder to store all the custom color palettes or color styles palettes that you create. You can add folders to store and organize the palettes for different projects. You can also copy a color palette or a color style palette or move the palette to a different folder.

 To quickly move a palette from one folder to another, drag the palette to the new folder.

Palette Libraries folder

The **Palette libraries** folder of the **Color palette manager** docker contains collections of preset color palettes.

The two main libraries of color palettes are **Process** and **Spot**. The color palette libraries are locked, which means that they cannot be edited. (The individual palettes can be copied as custom palettes, however, as explained in the next section.)

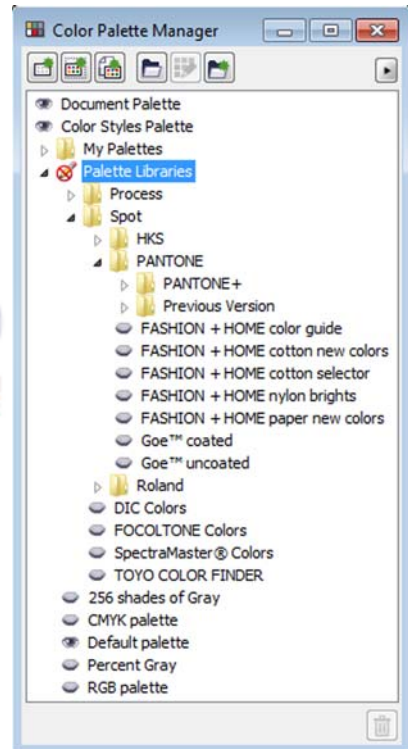

*The **Palette libraries** folder contains spot and process color palettes.*

The **Process** library contains the default RGB, CMYK, and Grayscale color palettes. In addition, you can find preset color palettes

that are based on particular themes and grouped in folders such as Nature and People.

The **Spot** library contains color palettes that are provided by third-party manufacturers, including HKS Colors, PANTONE, Focoltone®, and TOYO. You can use these color palettes when you need specific company-approved colors for your printed projects.

Creating custom palettes

You can create a custom palette to store all the colors or color styles that you need for a current or future project. By creating custom palettes, you can easily share a collection of colors or color styles with other people. You can access custom palettes from the **My palettes** folder of the **Color palette manager** docker. Custom palettes can include colors or color styles from any color model, including spot colors, or from any color palette in the **Palette libraries** folder.

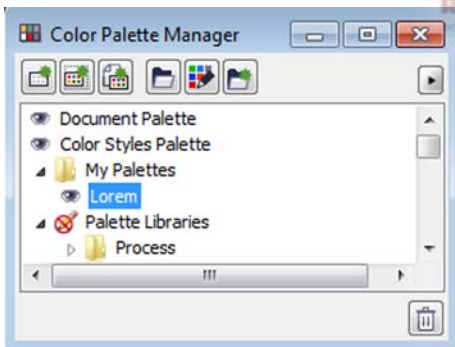

A custom color palette was added to the **My palettes** folder.

You cannot edit a palette in the **Palette libraries** folder. However, you can copy the palette to create a custom palette, which can then be edited.

 To copy a color palette from the **Palette libraries** folder of the **Color palette manager** docker, drag the palette to the **My palettes** folder.

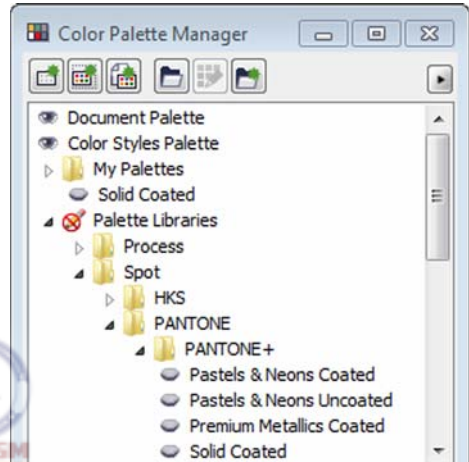

A copy of the **PANTONE Solid coated** spot color palette was created by dragging it from the **Palette libraries** to the **My palettes** folder.

Chapter 7: Color Management

Understanding color management **90**

Color management settings in
CorelDRAW Graphics Suite X6 **94**

Working with color profiles **97**

Soft proofing **98**

Working with color management policies **100**

Managing colors when opening documents **101**

Managing colors when importing and pasting
files **102**

Managing colors for print **102**

Using a safe CMYK workflow **103**

Managing colors for online viewing **103**

Chapter 7: Color Management

This chapter answers some basic questions about color management and introduces you to the color management features of CorelDRAW Graphics Suite X6.

Understanding color management

This section provides answers to the following commonly asked questions about color management:

- Why don't colors match?
- What is color management?
- Why do I need color management?
- How do I get started with color management?
- Is my monitor displaying the correct colors?
- Should I assign a color profile or convert colors to a color profile?
- What is a rendering intent?

Why don't colors match?

Different tools can be used during the creation and sharing of a document. For example, you can start with a file that was created in another application, or you can import an image that was captured by a digital camera or acquired from a scanner. After finishing the document, you can share it with a colleague by either printing or e-mailing it.

Each tool in your workflow has its own method of interpreting color. In addition, each tool has its own range of available colors, called a color space, which is a set of numbers that define how colors are represented.

In other words, when defining and interpreting color, each tool speaks a unique language. Consider a color in the color space of your digital camera: a vivid blue RGB color with the values Red = 0, Green = 0, and Blue = 255. This color may appear as a different color in the color space of your monitor. In addition, the color space of your printer may not contain a match for this color. As a result, when your document moves through the workflow, this vivid blue color gets lost in the translation and is not accurately reproduced. A color management system is designed to improve the communication of color in the workflow so that the color of the output matches your intended color.



Example of a document workflow

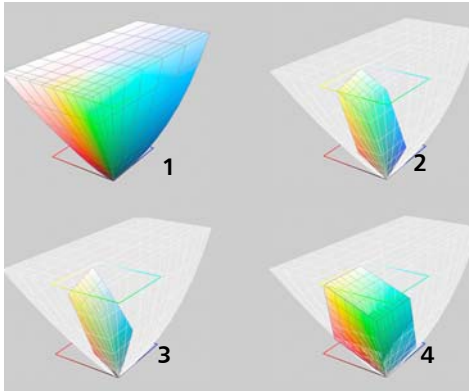

Colors are defined by their color space. 1. Lab color space. 2. sRGB color space, displayed against the Lab color space. 3. U.S. Web Coated (SWOP®) v2 color space. 4. ProPhotoRGB color space.

What is color management?

Color management is a process that lets you predict and control color reproduction, regardless of the source or destination of the document. It ensures a more accurate color representation when a document is viewed, modified, shared, exported to another file format, or printed.

A color management system, also known as a color engine, uses color profiles to translate the color values from one source to another. For example, it translates the colors that are displayed on the monitor into the colors that a printer can reproduce. Color profiles define the color space of monitors, scanners, digital cameras, printers, and the applications that you use to create or edit documents.

Why do I need color management?

If your document requires accurate color representation, you may want to learn more about color management. The complexity of your workflow and the ultimate destination of your documents are also important considerations. If your documents are destined

only for online viewing, color management may not be as important. However, if you plan to open documents in another application or if you are creating documents for print or multiple types of output, then proper color management is essential.

Color management lets you do the following:

- reproduce colors consistently across your workflow, especially when opening documents that were created in other applications
- reproduce colors consistently when sharing files with others
- preview (or “soft-proof”) colors before they are sent to their final destination, such as a printing press, a desktop printer, or the Web
- reduce the need to adjust and correct documents when sending them to different destinations

A color management system does not offer identical color matching, but it greatly improves color accuracy.

How do I get started with color management?

Here are some suggestions for adding color management to your workflow:

- Make sure that your monitor is displaying the correct colors. For more information, see “Is my monitor displaying the correct colors?” on page 92.
- Install color profiles for any input or output devices that you are planning to use. For more information, see “Installing and loading color profiles” on page 97.
- Become familiar with the color management features of CorelDRAW and Corel PHOTO-PAINT. The default settings for color management produce good color

results, but you can change these default settings so that they suit your specific workflow. For more information, see “Color management settings in CorelDRAW Graphics Suite X6” on page 94.

- Soft-proof documents to preview final results on-screen. For more information, see “Soft proofing” on page 98.
- Embed color profiles when saving or exporting files. In this way, you help ensure color consistency when the files are viewed, modified, or reproduced. For more information, see “Embedding color profiles” on page 98.

Is my monitor displaying the correct colors?

Calibrating and profiling the monitor are essential steps for ensuring color accuracy. When you calibrate a monitor, you set it to display colors according to an established standard of accuracy. After calibration, you can create a color profile of the monitor, which describes how the monitor interprets colors. This custom color profile is usually installed in your operating system by the profiling software, so it can be shared with other devices and applications. Calibration and profiling work together to achieve color accuracy: If a monitor is incorrectly calibrated, its color profile is not useful.

Calibration and profiling are complex and usually require third-party calibration devices, such as colorimeters and specialized software. Furthermore, improper calibration may do more harm than good. You can learn more about monitor calibration and custom color

profiles by researching color management techniques and products. You can also refer to the documentation that was provided with your operating system or monitor.

How you perceive the color that your monitor displays is also important for managing color consistency. Your perception is influenced by the environment in which you are viewing the documents. Here are some ways to create a suitable viewing environment:

- Ensure that your room has a consistent flow of light. For example, if the room is filled with sunlight, use a shade, or if possible, work in a room without windows.
- Set the monitor background to a neutral color, such as gray, or apply a grayscale image. Avoid using colorful wallpapers and screensavers.
- Don't wear bright clothing that can clash with the display of colors on the monitor. For example, wearing a white shirt reflects onto the monitor and alters your perception of color.

Should I assign a color profile or convert colors to a color profile?

When you assign a color profile, the color values, or numbers, in the document do not change. Instead, the application uses the color profile to interpret the document colors. However, when you convert colors to another color profile, the color values in the document change.

The best practice is to choose a suitable color space when you create a document and to use the same color profile throughout your



workflow. You should avoid assigning color profiles and converting colors to other color profiles while working on a document.

What is a rendering intent?

A color management system can perform effective translation of document colors to multiple devices. However, when converting colors from one color space to another, a color management system may be unable to match certain colors. This translation failure occurs because some colors in the source may not fit within the range (or gamut) of the destination color space. For example, the bright red and blue colors that you see on your monitor are often outside the gamut of colors that your printer can produce. These “out-of-gamut” colors can dramatically change the look of the document, depending on how they are interpreted by the color management system. Each color management system has four methods of interpreting out-of-gamut colors and mapping them into the gamut of the destination color space. These methods are known as “rendering intents.” The choice of a rendering intent depends on the graphical content of the document.

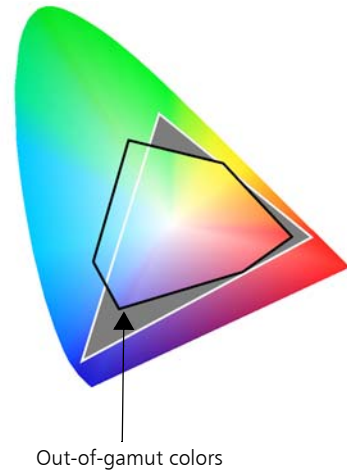
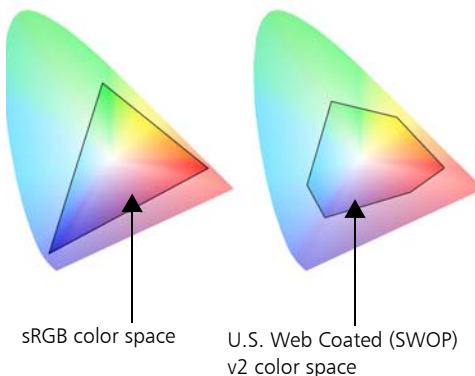

Many colors in an sRGB document may be out of gamut for the U.S. Web Coated (SWOP) v2 color space. The out-of-gamut colors are mapped into gamut according to the rendering intent.

The following rendering intents are available:

- The **Relative colorimetric** rendering intent is suitable for logos or other graphics that contain only a few out-of-gamut colors. It matches the out-of-gamut source colors with the closest in-gamut colors at the destination. This rendering intent causes the white point to shift. If you print on white paper, the whiteness of the paper is used to reproduce the white areas of the document. Therefore, this rendering intent is a good option if your document will be printed.
- The **Absolute colorimetric** rendering intent is suitable for logos or other graphics that require very precise colors. If no match is found for the source colors, then the closest possible match is used. The **Absolute colorimetric** and **Relative colorimetric** rendering intents are similar,

but the **Absolute colorimetric** rendering intent preserves the white point through the conversion and does not adjust for the whiteness of the paper. This rendering intent is used mainly for proofing.

- The **Perceptual** rendering intent is suitable for photographs and bitmaps that contain many out-of-gamut colors. The overall color appearance is preserved by changing all the colors, including the in-gamut colors, to fit within the range of colors at the destination. This rendering intent maintains the relationships between colors to produce the best results.
- The **Saturation** rendering intent produces more concentrated solid colors in business graphics, such as charts and graphs. Colors may be less accurate than those produced by other rendering intents.



The number of out-of-gamut colors (indicated by the green overlay) may influence your choice of a rendering intent. Left: The **Relative colorimetric** rendering intent is suitable for this photo, which contains only a few out-of-gamut colors. Right: The **Perceptual rendering** intent is a good choice for this photo, which contains many out-of-gamut colors.

Color management settings in CorelDRAW Graphics Suite X6

CorelDRAW Graphics Suite X6 has two types of color management settings: default settings

for color management and document color settings. The default settings for color management control the colors of new documents and any documents that do not contain color profiles (also known as “untagged documents”). Documents that were created in earlier versions of CorelDRAW Graphics Suite are treated as untagged. Document color settings affect only the colors of the active document.

Default settings for color management

The default settings for color management are essential for producing consistent colors.

- ✎ To access the default settings, click **Tools ▶ Color management ▶ Default settings**.

Point to a control to view its description, or click the **Help** button in the dialog box to find a relevant Help topic.

You can modify the default settings to suit your particular needs for color management.

- **Presets** can help ensure that your color settings are correct for the geographic region where the documents are created or for the location of their final output. Examples are the **North America Prepress** preset, which is suitable for projects to be printed by North American print service providers, and the **Europe Web** preset, which is suitable for Web projects that are created in Europe. For more information, see “Working with color management presets” in the Help.
- The **default color profiles** define the RGB, CMYK, and grayscale colors in new and untagged documents. You can change these settings so that all new documents use the color profiles that you specify. In some applications, default color

profiles are called “working space profiles.”

- The **primary color mode** determines the document color palette that is displayed when you open or start a document as well as the default color mode of a document that is exported as a bitmap. The primary color mode is set for all new and untagged documents, but you can change this setting for the active document in the **Document color settings** dialog box. Note that the primary color mode does not limit colors in a CorelDRAW document to a single color mode. The **Primary color mode** control is not available in Corel PHOTO-PAINT, where images always contain colors in a single color mode.
- The **rendering intent** lets you choose a method for mapping out-of-gamut colors in new and untagged documents. If the

default rendering intent is not suitable for the active document, you can change it in the **Document color settings** dialog box.

- The **color-conversion settings** determine how colors are matched when you are converting colors from one color profile to another. For example, you can change the color engine or specify options for converting pure black colors in RGB, CMYK, Lab, or grayscale documents.
- The **Spot color definition** control lets you display spot colors by using their Lab, CMYK, or RGB color values. These alternative color values are also used when spot colors are converted to process colors.
- **Color management policies** manage colors in files that you open, or in files that you import or paste into an active document.

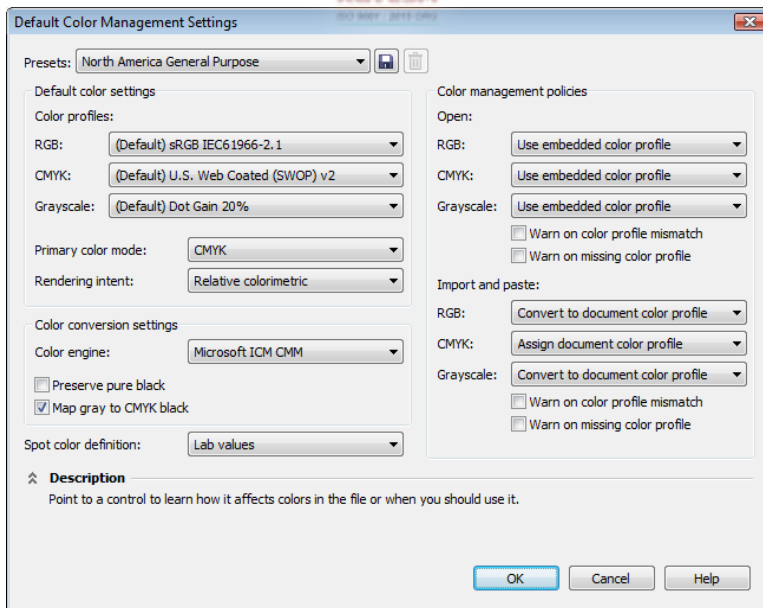

The **Default color management settings** dialog box in CorelDRAW lets you specify a wide range of settings.

Document color settings

You can view and change the color settings of the active document, without affecting new and untagged documents.

 To access document color settings, click **Tools ▶ Color management ▶ Document settings**.

The upper part of the **Document color settings** dialog box lists both the profiles that

are assigned to the active document and the default color profiles of the application. The color profiles that are assigned to an active document determine the document color space for RGB, CMYK, and grayscale colors.

The controls in the **Edit document color settings** area let you assign other color profiles to a document or convert colors to other color profiles.

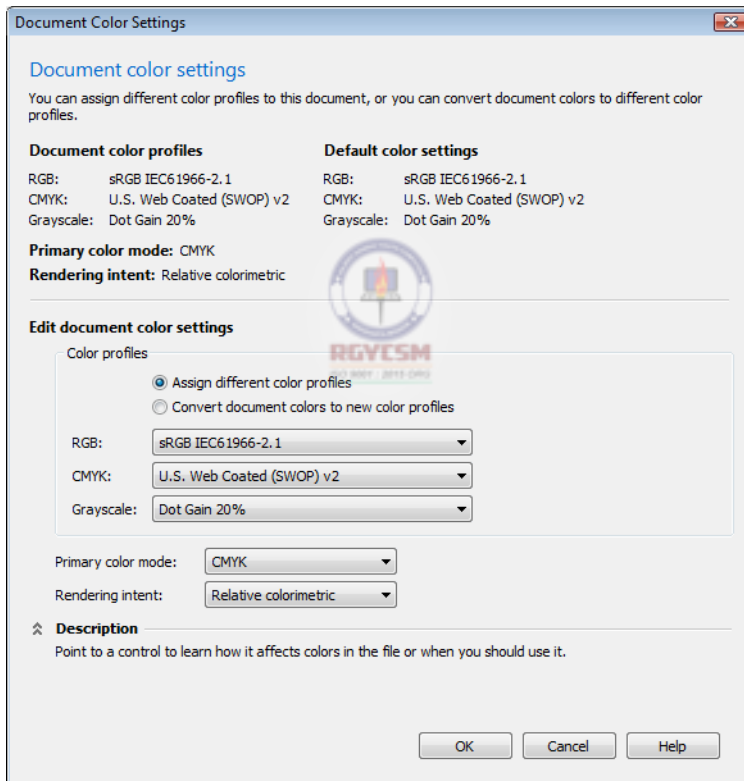

The **Document color settings** dialog box in CorelDRAW lets you view and modify the color settings in the active document without changing the default settings for color management.

Working with color profiles

To ensure color accuracy, a color management system needs ICC-compliant profiles for monitors, input devices, external monitors, output devices, and documents.

- **Monitor color profiles** define the color space that your monitor uses to display document colors. CorelDRAW and Corel PHOTO-PAINT use the primary monitor profile that is assigned by the operating system.
- **Input device color profiles** are used by input devices such as scanners and digital cameras. These color profiles define which colors can be captured by specific input devices.
- **Display color profiles** include monitor profiles that are not associated with your monitor in the operating system. These color profiles are especially useful for soft-proofing documents for monitors that are not connected to your computer.
- **Output device color profiles** define the color space of output devices such as desktop printers and printing presses. The color management system uses these profiles to map document colors to the colors of the output device.
- **Document color profiles** define the RGB, CMYK, and grayscale colors of a document. Documents that contain color profiles are known as “tagged documents.”

Many color profiles are installed with CorelDRAW Graphics Suite or can be generated with profiling software. Manufacturers of monitors, scanners, digital cameras, and printers also provide color profiles.

Installing and loading color profiles

If you don't have the necessary color profile, you can install it, or you can load it within the application. Installing a color profile adds it to the **Color** folder of the operating system; loading a color profile adds it to the **Color** folder of the application. CorelDRAW Graphics Suite can access color profiles from both **Color** folders.

 To install a color profile from Windows® Explorer, right-click a color profile, and click **Install profile**.

To load a color profile from the **Default color management settings** dialog box, choose **Load color profiles** from the **RGB**, **CMYK**, or **Grayscale** list box in the **Default color settings** area.

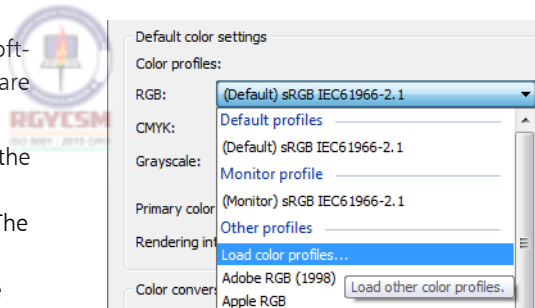

Loading a color profile

Assigning color profiles

If the document has a color profile that is not suitable for the required destination, you can assign a different color profile to the document. For example, if the document is intended to be displayed on the Web or to be printed on a desktop printer, you should make sure that sRGB is the document RGB profile. If the document is destined for print production, the Adobe® RGB (1998) profile is a better choice, because it has a larger gamut

and produces good results when RGB colors are converted to a CMYK color space.

When you assign a different color profile to a document, the colors may appear different, although the color values do not change.

 To change the assigned color profiles for the active document in CorelDRAW, click **Tools ▶ Color management ▶ Document settings**. Next, enable the **Assign different color profiles** option, and choose color profiles from the **RGB**, **CMYK**, and **Grayscale** list boxes.

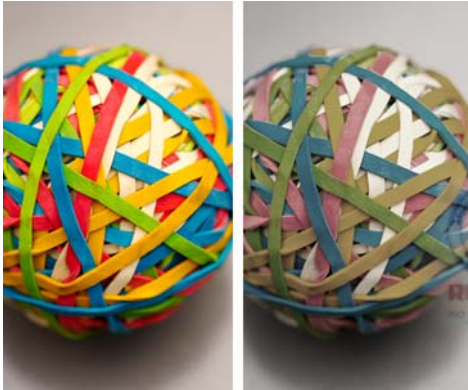

Left: The SWOP 2006_Coated3v2.icc color profile is assigned to the active document. Right: When the Japan Color 2002 Newspaper color profile is assigned to the document, the colors appear much less saturated.

Converting colors to other color profiles

When you convert document colors from one color profile to another, the color values in the document are changed according to the rendering intent, but the appearance of colors is preserved. The main purpose of converting colors is to match the appearance of colors in the source color space as closely as possible to colors in the destination color space. Because multiple color conversions deteriorate accuracy, it is recommended that you convert

colors only once. Wait until the document is ready and you are sure of the color profile that will be used for the final output.

 To convert document colors to those of other color profiles, click **Tools ▶ Color management ▶ Document settings**. Next, enable the **Convert document colors to new color profiles** option, and choose color profiles from the **RGB**, **CMYK**, and **Grayscale** list boxes.

You can also choose a color engine and choose how to handle black and grayscale colors during conversion. For more information, see “Choosing color-conversion settings” in the Help.

Embedding color profiles

When you save or export a document to a file format that supports color profiles, the color profiles are embedded in the file by default. Embedding a color profile attaches the color profile to the document to ensure that the same colors you used are shared with anyone who views or prints the document.

 To embed a color profile when saving or exporting a document, be sure that the **Embed color profiles** check box is enabled in the **Save as** or **Export** dialog box.

Soft proofing

Soft proofing provides an on-screen preview of a document as it will appear when it is reproduced by a specific printer or displayed on a specific monitor. Unlike the “hard-proofing” technique that is used in a traditional printing workflow, soft proofing lets you look at the final result without committing ink to paper.

To turn soft proofing on, click **Tools ▶ Proof colors**. The status bar indicates that soft proofing has been turned on.



Soft proofing is turned on.

When you soft-proof a document, CorelDRAW and Corel PHOTO-PAINT use color profiles to simulate the environment of particular output devices.



Top left: An RGB color profile is assigned to the document. Middle and right: Assigning a specific CMYK profile allows an on-screen simulation of the printed output.

To simulate the environment of a specific device, you must choose the color profile of the device in the **Color proof settings** docker (**Tools ▶ Color proof settings**).

Because the color spaces of the document and device are different, some document colors may not have a match in the gamut of the device color space. You can enable the gamut warning, which lets you preview the on-screen colors that cannot be reproduced accurately by the device. When the gamut warning is enabled, an overlay highlights all out-of-gamut colors for the device that you are simulating.

In addition to previewing colors on-screen, you can save a soft proof to popular file formats, such as JPG and PDF, to share with clients or colleagues. You can also print a hard proof that is based on the active soft-proof settings. If you often need to proof colors for a specific output, you can save the color-proof settings as a preset.

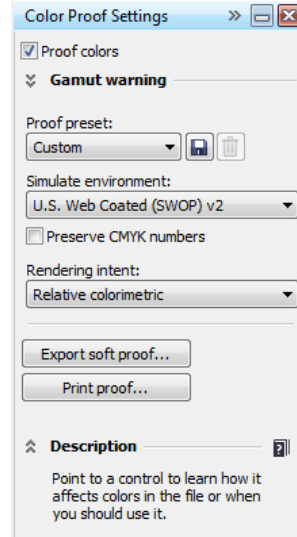

The **Color proof settings** docker lets you soft-proof projects by simulating the environment of various output devices.



Highlighting out-of-gamut colors

For more information about soft proofing, see “Soft proofing” in the Help.

Working with color management policies

Color management policies determine how colors are managed in documents that you open and work with in an application. In CorelDRAW and Corel PHOTO-PAINT, you can set one color-management policy for opening documents and another for importing and pasting files and objects in the active document.

The default policies for color management in CorelDRAW Graphics Suite can help you produce consistent colors in your documents. If you are familiar with color management, you can modify the default color policies to suit your specific workflow.

 To change a color management policy, click **Tools ▶ Color management ▶ Default settings**, and set options in the **Color management policies** area.

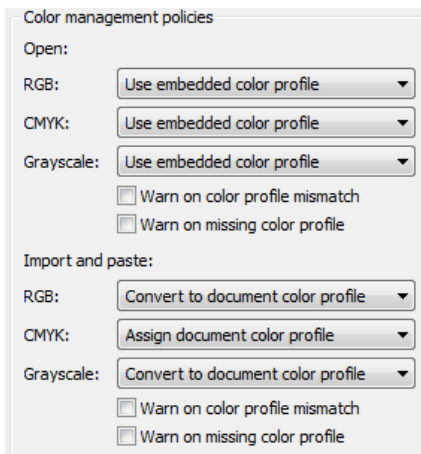

Color management policies area of the **Default color management settings** dialog box

In the **Default color management settings** dialog box, you can choose one of three color-management options for opening documents.

- The **Use embedded color profile** option assigns the color profiles that are embedded in the document. This option is recommended, because it preserves the original color appearance and color values of the document.
- The **Assign default color profile** option uses the default color profiles to define document colors. Color values are preserved, but the appearance of colors may change.
- The **Convert to default color profile** converts document colors to the default color profiles. The appearance of document colors is preserved, but the color values may change.

In the same dialog box, you can choose one of three color-management options for importing and pasting files.

- The **Convert to document color profile** option converts the colors of the imported or pasted file to the color profile of the active document. This option is used when the imported file contains a color profile that does not match the color profile of the document.
- The **Assign document color profile** option assigns the color profile of the document to the imported or pasted file. The color values of the file are preserved, but the color appearance may change.
- The **Use embedded color profile** option uses the color profile that is embedded in the file. This option preserves the color values and color appearance of the imported or pasted file. This option converts document colors to the color

profile that is embedded in the imported or pasted file.

The files that you are opening or importing may be missing color profiles, or may contain color profiles that do not match the default color profiles. By default, the applications do not warn you about missing or mismatched color profiles but make color management choices that produce good results. However, you can activate warning messages in the **Color management policies** area of the **Default color management settings** dialog box if you want to have full control over the colors in your documents.

Managing colors when opening documents

The default color-management policy for opening documents preserves colors in all tagged documents that you open and assigns

the default color profiles to untagged documents.

If you activate warning messages for missing and mismatched color profiles, you can choose additional color management options. For example, if a color profile is missing from a file, you can assign a color profile that is different from the default color profile of the application. This option is recommended only if you know the original color space of the document and have the associated color profile installed. In addition to assigning a specific color profile, you can convert document colors from the assigned color profile to the default color profile. Colors will appear as they would in the assigned color space, but the color values may change.

For more information, see “Managing colors when opening documents” in the Help.

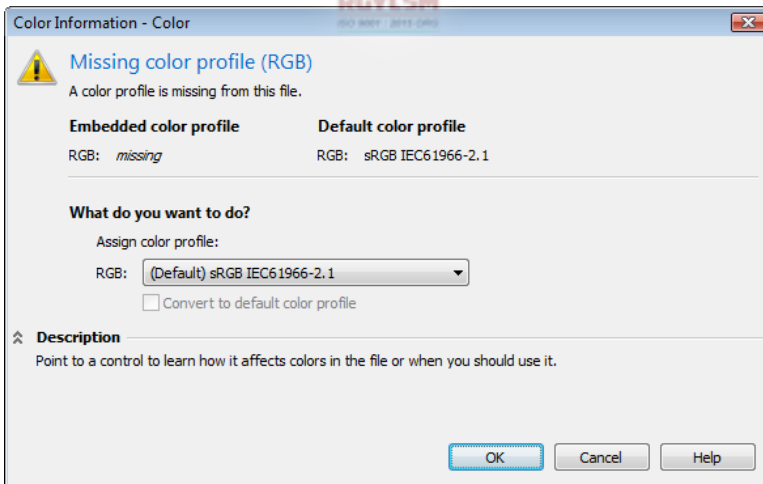

CorelDRAW displays this warning dialog box for a document that is missing an RGB color profile.

Managing colors when importing and pasting files

If you use the default color policy for importing and pasting files, the colors in files that you import or paste are converted to the color profile of the active document. If the color profile of the imported or pasted file matches the color profile of the active document, no color conversion is performed.

By activating warning messages for missing and mismatched profiles, you can access additional options. For example, if a file

contains a mismatched color profile, you can choose to ignore the embedded color profile and assign the document color profile to preserve color values. Alternatively, you can convert document colors to the embedded color profile of the imported or pasted file. Note that this option preserves the appearance and color values of the imported or pasted file but changes the color values of the active document.

For more information, see “Managing colors when importing and pasting files” in the Help.

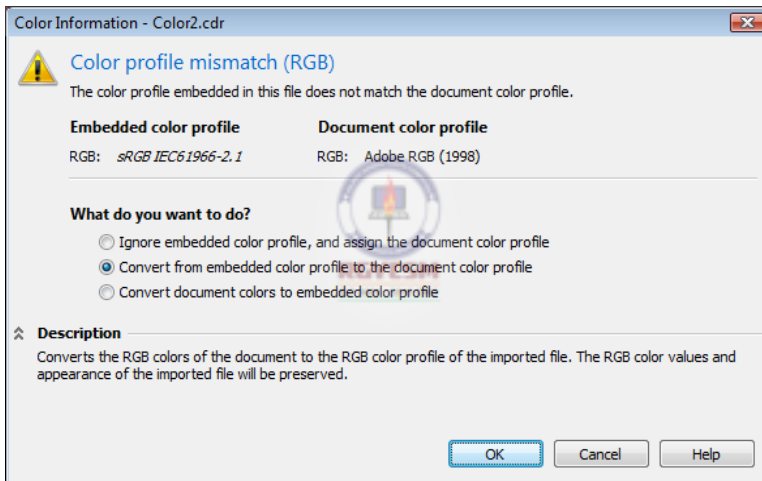

Corel PHOTO-PAINT displays this warning dialog box for a file that contains a mismatched color profile.

Managing colors for print

By default, CorelDRAW Graphics Suite does not perform color conversions when a document is sent to the printer. The printer receives the color values and interprets the colors. However, if the operating system includes a color profile that is associated with the printer, this color profile is detected by CorelDRAW Graphics Suite and used to

convert document colors to the color space of the printer.

If you have a PostScript® printer, any necessary color conversion can be managed by either CorelDRAW or this printer. When the application manages the color conversion, document colors are converted from the assigned color space to the color space of the PostScript printer. If you use this method, you must disable color management in the printer

driver. Otherwise, both the application and the printer manage colors during printing, and document colors are corrected twice, which causes unwanted color shifts.

When the PostScript printer converts document colors, the color management feature must be enabled in the printer driver. Only PostScript printers and RIP engines that support printer color conversions can be used in this advanced method. Although it increases the file size, this method has the advantage of ensuring consistent colors when you send the same print job to different print service providers.

For more information about reproducing colors for print, see “Printing colors accurately” in the Help.

You can also manage colors in PDF files that you create for commercial printing. For more information, see “Specifying color management options for exporting PDF files” in the Help.

Using a safe CMYK workflow

Often, you may use specific CMYK color values in your projects. To ensure reliable color reproduction, you may obtain these CMYK color values from a color swatch book. By preserving these CMYK color values throughout the printing process, you can help prevent unwanted color conversions and ensure that colors are reproduced as they appear in the original design. A workflow that preserves the CMYK color values is known as a “safe” CMYK workflow.

CorelDRAW Graphics Suite supports a safe CMYK workflow. By default, CMYK color values are preserved in any document that you open, import, or paste. Also, CMYK color values are

preserved by default when you print documents.

In some cases, you may want to bypass the safe CMYK workflow and preserve the appearance of CMYK colors when you open, import, or paste documents. This option is useful when you want to see the original colors of a design on-screen, or view a copy that is printed to a desktop printer. To preserve the appearance of CMYK colors, you can set color management policies that convert CMYK colors in documents that you open, import, or paste. In addition, when printing to a PostScript printer, you can convert CMYK colors to the printer color profile by disabling the **Preserve CMYK numbers** check box on the **Color** page of the **Print** dialog box.

Managing colors for online viewing

Managing colors for online viewing can be even more complex than managing colors for print. Documents and images on the Web are displayed on a wide variety of monitors, which are often uncalibrated. In addition, most Web browsers do not support color management and ignore the color profiles that are embedded in files.

When you design documents for exclusive Web use, it is recommended that you use the sRGB color profile as your document RGB color profile and choose RGB colors. If a document contains a different color profile, you should convert document colors to sRGB before saving the document for use on the Web.

When you create a PDF file for online viewing, you can embed color profiles in the file to reproduce colors consistently in Adobe® Reader® and Adobe Acrobat. For more information, see “To specify color



management options for exporting PDF files” in the Help.

When you start a new document that is destined for online viewing, you can choose a preset that can help you achieve good color results. In addition, both CorelDRAW and Corel PHOTO-PAINT offer color management presets for Web documents. For more information, see “Working with color management presets” in the Help.



Chapter 8: Working with Text

Adding artistic and paragraph text in
CorelDRAW **106**

Adding text in Corel PHOTO-PAINT **107**

Formatting characters **107**

Working with OpenType fonts **108**

Spacing text **110**

Aligning text **112**

Additional text effects **113**

Working with text frames **114**

Working with text from an older version of
CorelDRAW Graphics Suite **116**

Chapter 8: Working with Text

Text is an important element in the structure and layout of documents; it not only communicates a specific message to the readers, but also serves as a design element. CorelDRAW and Corel PHOTO-PAINT provide a wide variety of tools that let you manipulate and fine-tune the appearance of text. This chapter introduces you to some of the options for adding and formatting text.

Adding artistic and paragraph text in CorelDRAW

In CorelDRAW, you can create two types of text objects — artistic text and paragraph text. The option that you choose depends on your needs and requirements.

Artistic text allows you to quickly add a single word or a short line of text. It is perfect for inserting headings or adding text to a path.



You can quickly add text to a document by using artistic text.

To add artistic text, click the **Text** tool , click in the document window, and type.

Paragraph text is useful for adding large amounts of text that have more complex formatting requirements. Paragraph text is contained in a text frame, and it is suitable for creating documents such as brochures, newsletters, or catalogs.



You can add large amounts of text to a document by using paragraph text.

To add paragraph text, click the **Text** tool , drag in the document window until the frame is the size you want, and type text in the text frame.

You can place text inside a graphic object, which increases the number of different shapes that you can use as text frames.

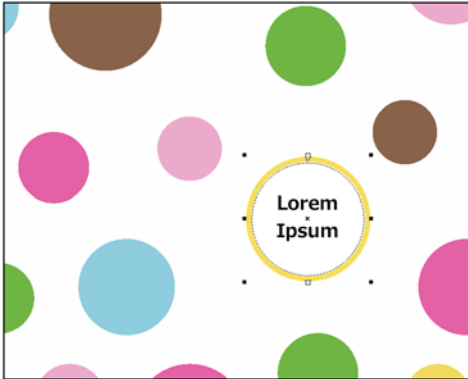

You can convert a graphic object into a text frame.

- To convert an object into a text frame, right-click the object, choose **Frame type**, and click **Create empty text frame**.

You can type text directly in a frame or, if you want to use existing content, you can import or paste text from a file.

- To import text, click **File ▶ Import**. Choose a text file, and click **Import**. Specify any formatting options in the **Importing/Pasting text** dialog box. Position the import cursor in the document window, and click.

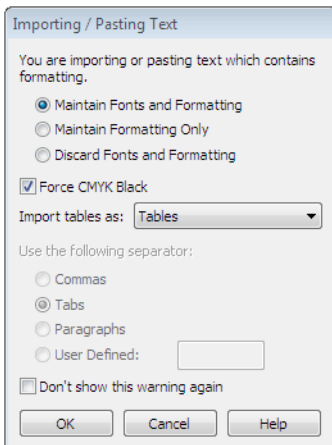

The **Importing/Pasting text** dialog box lets you specify formatting options for importing text.

Adding text in Corel PHOTO-PAINT

You can add lines of text, such as titles or captions, to enhance your images.

- To add text to an image, click the **Text** tool , click in the image, and type.



Text added to an image in Corel PHOTO-PAINT

- You can manipulate text as you would any other type of object. For example, you can select, move, size, scale, rotate, flip, and skew a text object.

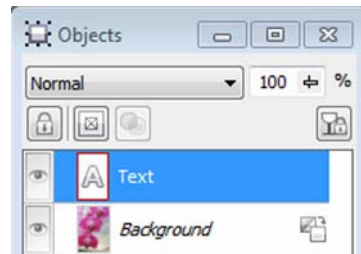



Text is displayed as a text object in the **Objects** docker.

Formatting characters

You can enhance the appearance of text by selecting and formatting characters.

- To select text for editing, click the **Text** tool , and drag across the text.

In CorelDRAW, you can use the **Object properties** docker to modify character properties, such as font type or text color. You can also access most paragraph formatting options and text frame settings.

 To access character formatting options in CorelDRAW, click **Window** ▶ **Dockers** ▶ **Object properties**, and click the **Character** button .

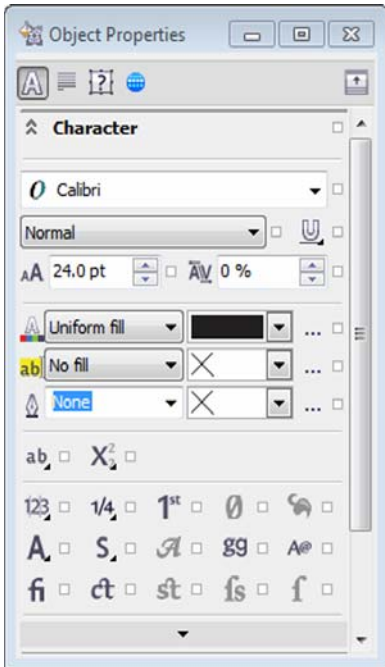

The **Object properties** docker in CorelDRAW X6 lets you set character attributes.

In Corel PHOTO-PAINT X6, you can use the updated **Character formatting** docker to specify text formatting settings.

 To access character formatting options in Corel PHOTO-PAINT, click **Object** ▶ **Text** ▶ **Character formatting**.

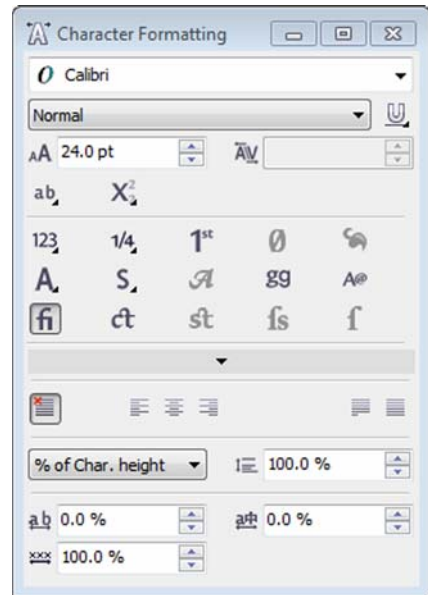

The **Character formatting** docker in Corel PHOTO-PAINT lets you modify character properties.

Working with OpenType fonts

CorelDRAW Graphics Suite X6 allows you to use the advanced typographic features of OpenType fonts.



The OpenType font specification was created jointly by Adobe and Microsoft. OpenType fonts extend the capabilities of TrueType® fonts and other older font technologies. Unlike older fonts, an OpenType font can store a vast array of typographic features.



Some OpenType fonts include stylistic alternates that let you choose an alternative appearance for a selected character.

The most notable advantages of OpenType fonts are

- cross-platform support (Windows and Mac®)
- extended character sets that offer better language support and advanced typographic features
- coexistence with Type 1 (PostScript) and TrueType fonts
- support for a larger glyph limit (64k)

 To access OpenType features in CorelDRAW, click **Window ▶ Dockers ▶ Object properties**, and click the **Character** button .

To access OpenType features in Corel PHOTO-PAINT, click **Object ▶ Text ▶ Character formatting**.



The OpenType features let you apply alternate appearances to selected characters.



OpenType fonts let you choose an alternative appearance for an individual character (also referred to as a glyph) or a sequence of characters. For example, you can choose alternative glyphs for numbers, fractions, or ligature sets.



Applying an OpenType fraction feature to text

It's important to note that the features supported by each OpenType font can vary. For example, a font may include ordinals, but not

ligatures. CorelDRAW Graphics Suite X6 supports only the features that are available in a font. To quickly discover what OpenType features you can apply to selected text, enable the **Interactive OpenType** option. An indicator arrow appears below the text. Click the indicator to access a list of the most popular OpenType features that are available for the selected text.

 To enable the **Interactive OpenType** feature, select text by using the **Text** tool , and enable the **Interactive OpenType** button  on the property bar.

To display a list of the most popular OpenType features, click the indicator arrow  below the text. To quickly apply a feature, hover over an option in the list and click the option.

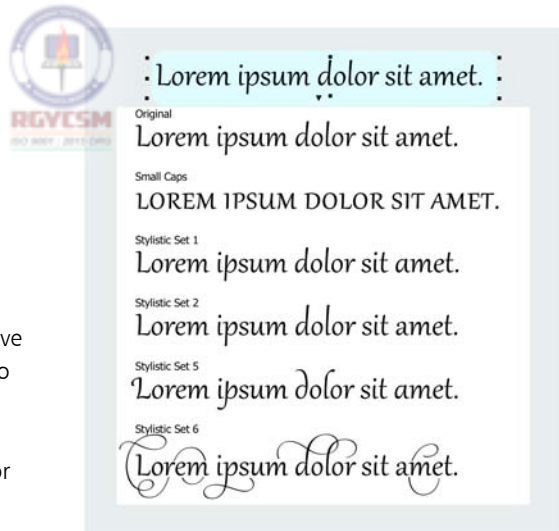

*The **Interactive OpenType** indicator appears in the document window when an OpenType feature is available for the selected text.*

If you use an OpenType font that does not support a feature or a non-OpenType font, CorelDRAW Graphics Suite X6 provides synthesized versions of superscript, subscript,

and small caps. The synthesized characters are produced by altering the characteristics of the default character.

LOREM



The red characters have a synthesized version of small caps applied.

Spacing text

Fine-tuning or copyfitting text often involves changing the spacing between characters and paragraphs. You adjust spacing to improve readability and achieve visual balance. When letters, words, or lines are too close together or too far apart, text becomes difficult to read.

There are different ways of adjusting spacing:

- **Kerning** refers to the repositioning of two characters to balance the optical space between them. For example, kerning is often used to decrease the space in character pairs such as AW, WA, VA, or TA. Kerning makes letters appear balanced and proportional, especially at larger font sizes.

 To kern text in CorelDRAW, click the **Text** tool , and select the characters that you want to kern. Click the **Character** button in the **Object properties** docker. Type a value in the **Range kerning** box.



To kern text in Corel PHOTO-PAINT, click the **Text** tool , and select the characters that you want to kern. Click **Object** ▶ **Text** ▶ **Character formatting**. In the **Character formatting** docker, type a value in **Range kerning** box.

SOLUTA

SOLUTA

Text without and with kerning

- **Character spacing**, which is also known as letter spacing, allows you to control the spacing between characters in a block of artistic or paragraph text.

 To adjust character spacing in CorelDRAW, click the **Text** tool , and select the text that you want to modify. Click the **Paragraph** button  in the **Object properties** docker. Type a value in the **Character spacing** box.



To adjust character spacing in Corel PHOTO-PAINT, click the **Text** tool , and select the characters that you want to modify. Click **Object** ▶ **Text** ▶ **Character formatting**. In the **Character formatting** docker, type a value in the **Character spacing** box.

Lorem ipsum

Lorem ipsum

A block of text without and with character spacing

- **Word spacing** lets you change the spacing between words. It's quite useful for decreasing the extra spacing that's inserted between words in fully justified text.



 To adjust word spacing in CorelDRAW, click the **Text** tool , and select a text object. Click the **Paragraph** button  in the **Object properties** docker. Type a value in the **Word spacing** box.

To adjust word spacing in Corel PHOTO-PAINT, click the **Text** tool , and select the text object. Click **Object** ▶ **Text** ▶ **Character formatting**. In the **Character formatting** docker, type a value in the **Word spacing** box.

Lorem ipsum Lorem ipsum

You can change the spacing between words to improve the readability and layout.

- **Line spacing**, also known as leading or interline spacing, lets you adjust the distance between lines of text. For text objects in Corel PHOTO-PAINT and artistic text in CorelDRAW, changes to the line spacing affect only lines separated by a hard return. For paragraph text in CorelDRAW, changes affect the lines within the same paragraph.

 To adjust line spacing in CorelDRAW, click the **Text** tool , and select a text object or a block of text. Click the **Paragraph** button  in the **Object properties** docker. Type a value in the **Line spacing** box.



To adjust line spacing in Corel PHOTO-PAINT, click the **Text** tool , and select a text object. Click **Object** ▶ **Text** ▶ **Character formatting**. In the **Character formatting** docker, type a value in the **Line spacing** box.

Lorem ipsum dolor sit amet,
consectetur adipiscing elit.

Lorem ipsum dolor sit amet,
consectetur adipiscing elit.

A block of text without and with line spacing

- **Paragraph spacing** is an option that is available in CorelDRAW. It allows you to adjust the spacing between paragraphs in a text frame. It's quite useful for copyfitting text. It can help you fit text in a page or a frame with a fixed size.

 To adjust paragraph spacing in CorelDRAW, click the **Text** tool , and select a paragraph. Click the **Paragraph** button  in the **Object properties** docker. Type values in the **Before paragraph spacing** and **After paragraph spacing** boxes.



• Lorem ipsum dolor sit amet,
consectetur adipiscing elit.

• Fusce fermentum dui ut nulla
varius eu rutrum nunc varius.

• Aenean posuere, risus et egetas
sollicitudin.

Paragraph spacing is useful for adjusting the spacing between bulleted items in a bulleted list.

- **Language spacing** lets you control the spacing between words in different languages, such as Latin-based, Asian, or Middle Eastern languages, that coexist in a text object. For example, you can specify the spacing between a word in Japanese and a word in English that appear in a text object.

 To adjust language spacing in CorelDRAW, click the **Text** tool , and select a

paragraph. Click the **Paragraph** button  in the **Object properties** docker. Modify the value in the **Language spacing** box.

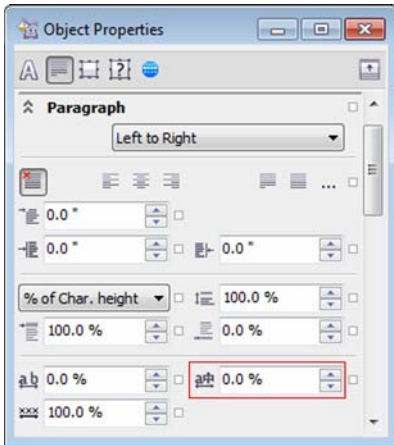

You can change the spacing between words in different languages in the **Paragraph** area of the CorelDRAW **Object properties** docker.



To adjust language spacing in Corel PHOTO-PAINT, click the **Text** tool , and select text. Click **Object** ▶ **Text** ▶ **Character formatting**. In the **Character formatting** docker, specify a value in the **Language spacing** box.



Aligning text



CorelDRAW Graphics Suite X6 provides various options for aligning text. You can align text in relation to its frame or bounding box, or in relation to other objects.

In CorelDRAW, you can align both paragraph and artistic text. You can align paragraph text horizontally and vertically in relation to its text frame. You can align artistic text only horizontally. If you haven't shifted the characters horizontally, applying no alignment produces the same result as applying left alignment.

In Corel PHOTO-PAINT, you can align a text object only horizontally.

To align text horizontally in CorelDRAW, select the text by using the **Text** tool , click the **Horizontal alignment** button  on the property bar, and choose an option from the list.

To align text horizontally in Corel PHOTO-PAINT, select the text by using the **Text** tool , click the **Text alignment** button  on the property bar, and choose an option from the list.

To align paragraph text vertically in CorelDRAW, click the **Pick** tool , and select a text frame. Click the **Frame** button  in the **Object properties** docker. In the **Frame** area of the **Object properties** docker, click the **Vertical alignment** button, and choose an option from the list.



PELLENTESQUE UT LACUS LIBERO

Fusce auctor hendrerit pulvinar. In malesuada facilisis vestibulum. Nullam urna nulla, euismod id tincidunt quis, fermentum vitae nibh. Nullam fermentum laoreet fermentum. Cras a facilisis augue. Integer euismod lacus et nibh vehicula vel gravida odio auctor. Duis porta vehicula gravida. Maecenas in felis lorem. Integer id iaculis orci.



Fusce eget erat at justo cursus facilisis. In hac habitasse platea dictumst. Donec euismod, orci eu hendrerit pharetra, mauris tortor pulvinar dui, ac suscipit lorem justo id nunc. Nulla facilisi. Quisque sit amet arcu at justo aliquet accumsan. Vestibulum sollicitudin justo a nibh vulputate ultrices.

Duis mi turpis, aliquet vel faucibus non, elementum eget orci. Donec eu justo in enim convallis portitor. Suspendisse elit augue, viverra nec adipiscing quis, sagittis at est. Praesent ultricies fermentum pulvinar. Phasellus nisi urna, interdum vitae aliquet vitae, aliquet quis est.

The title is centered in the text frame. The body text is left-aligned in the text frame. The content of the text frame is centered vertically.

In CorelDRAW, you can align text within a frame or in different frames by using the baseline grid. This is useful, for example, when you want to align two or more text frames that contain different fonts, font sizes, and spacing. When you align paragraph text to the baseline



grid, the line spacing is adjusted automatically so that the lines of text sit on the baseline grid. When text is aligned to the baseline grid, the line spacing is controlled by the grid rather than by the text properties that have been previously set. You can adjust the spacing of the baseline grid.

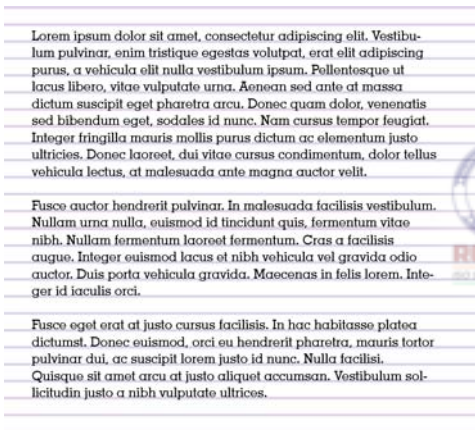

 To align paragraph text to the baseline grid in CoreDRAW, click the **Text** tool , and select the text. Click the **Frame** button  in the **Object properties** docker. In the **Frame** area of the **Object properties** docker, click the **Align to baseline grid** button.



Paragraph text aligned to the baseline grid

You can also align text to another object.

 To align text to an object in CoreDRAW, click the **Pick** tool , hold down **Shift**, click a text object, and then click the object with which you want to align the text. Click **Arrange** ▶ **Align and distribute** ▶ **Align and distribute**, and choose an option from the list.

 To align text to an object in Corel PHOTO-PAINT, click the **Object pick** tool , hold down **Shift**, click a text

object, and then click the object with which you want to align the text. Click **Object** ▶ **Arrange** ▶ **Align and distribute**, and choose an option in the **Align and distribute** dialog box.





The artistic text object is aligned with the selected object.

Additional text effects

CoreDRAW also includes additional options that let you enhance text in different ways.

You can insert a drop cap, also known as an initial cap, at the beginning of a paragraph to draw the attention of the reader and add a unique style to your document. When you apply a drop cap, the first letter of the paragraph is displayed in a larger font and is inset into the body of the paragraph text.

 To quickly add a drop cap to paragraph text in CoreDRAW, select a text frame by using the **Text** tool . Click the **Paragraph** button  in the **Object properties** docker. Click the down arrow located at the bottom of the **Paragraph** area to display additional options. Enable the **Drop caps** check box.

To modify a drop cap, click the **Drop cap settings** button to the right of the **Drop caps** check box in the **Paragraph** area of the **Object properties** docker.

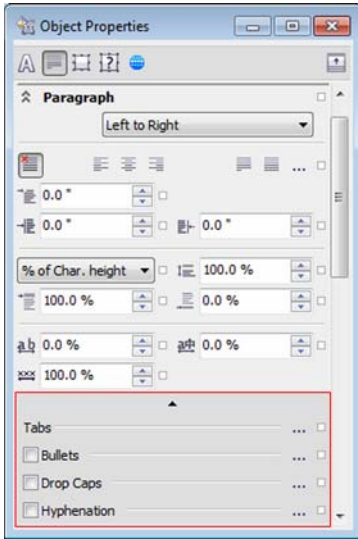

Displaying additional paragraph formatting options

*V*ivamus
 scelerisque enim
 et est ullamcorper a
 fringilla lectus dictum.

A drop cap applied to the initial letter of a paragraph

If you want to visually set paragraphs apart and help readers scan your document quickly, you can organize information with bulleted lists. A bullet is a text symbol that precedes each item in a list.

- Lorem ipsum dolor sit amet, consectetur adipiscing elit.
- Quisque tempor, nibh eget dapibus fringilla, felis nibh interdum quam.
- Nullam vel metus vel orci imperdiet vulputate.

You can apply bullets to existing paragraph text.

In CoreDRAW, you can quickly convert text to a bulleted list.

To convert text to a bulleted list, select paragraph text by using the **Text** tool . Click the **Paragraph** button in the **Object properties** dock. In the **Paragraph** area of the **Object properties** dock, click the down arrow located at the bottom of the area to display additional options. Enable the **Bullets** check box.

To modify a bullet, click the **Bullet settings** button to the right of the **Bullets** check box in the **Paragraph** area of the **Object properties** dock.

Working with text frames

In CoreDRAW, you can customize a text frame by modifying its size, position, and settings.



To add a background color to a frame, select a frame by using the **Pick** tool . Click the **Frame** button in the **Object properties** dock. In the **Frame** area of the **Object properties** dock, click the **Background color** button.

Lorem ipsum dolor sit amet, consectetur
 adipiscing elit. Vivamus convallis
 pellentesque lacus, ac lacinia ante
 scelerisque quis. Donec vel felis ac neque
 dictum sollicitudin ut in ante.

Adding a background color to a text frame

When you type in a frame, the size of the frame does not automatically adjust to accommodate the text. Therefore, if you add more text than the frame allows, the text continues past the lower-right border of the text frame, but remains hidden. The color of the frame turns red to alert you that there is additional text.

The icon of the text flow tab at the bottom of the frame also changes.

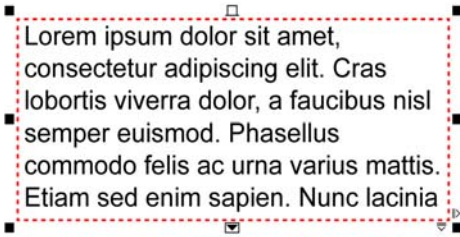

The red color of the frame and the icon of the text flow tab indicate text overflow.

You have a few options for fixing text overflow:

- Resize the text frame.

To resize a text frame, select the frame by using the **Pick** tool , and drag one of the selection handles.





Using a selection handle to change the width of a text frame.

- Adjust the text size.

To adjust the size of text, select the text in the frame by using the **Text** tool , click the **Font size** list box on the property bar, and choose a size from the list.

- Link the frame to another text frame.

To direct overflow text to another frame, select the starting frame by using the **Text** tool , click the **Text flow** tab  at the bottom of the frame, and when the pointer changes to a **Link to** pointer , click the frame into which you want to continue the text flow.

You can lay out text in columns, which are useful for designing text-intensive projects, such as newsletters, magazines, and newspapers. You can create columns of equal or varying widths and gutters.

To add columns to a text frame, click the **Text** tool , and select a text frame. Click the **Frame** button in the **Object properties** docker. In the **Frame** area of the **Object properties** docker, click the **Column settings** button, and specify column settings in the **Column settings** dialog box.

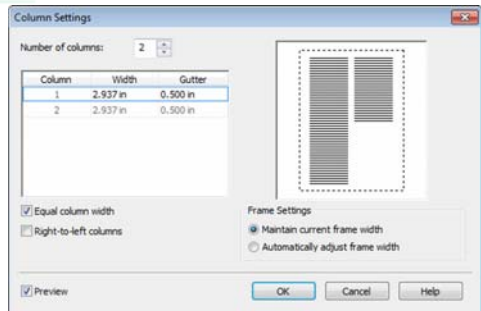

The **Column settings** dialog box

Working with text from an older version of CorelDRAW Graphics Suite

If you open a document with text that was created in a previous version of CorelDRAW Graphics Suite, such as CorelDRAW Graphics Suite X5, you need to update the legacy text before you can use the new CorelDRAW X6 text features, such as OpenType features and the baseline grid.

 To use the latest text features in a document that contains legacy text, open the document, and click **Update** on the **Update** toolbar that appears at the top of the document window, or click **Update** in the **Object properties** docker.

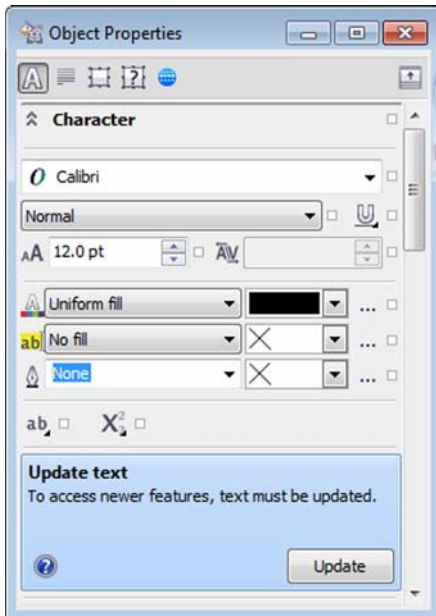

The control for updating text appears in the **Object properties** docker.



Chapter 9: Styles and Style Sets

Understanding styles and style sets **118**

Creating styles and style sets **120**

Applying styles and style sets **121**

Editing styles and style sets **122**

Exporting and importing style sheets **123**

Finding objects that use a specific style or style set **124**

Breaking the link between an object and a style or style set **124**

Chapter 9: Styles and Style Sets

CorelDRAW provides advanced style capabilities that allow you to format your documents with speed, ease, and consistency. You can create and apply styles and style sets to a variety of graphic and text objects in your documents. This chapter introduces you to different methods of creating and using object styles in CorelDRAW.

Understanding styles and style sets

If you have worked with desktop-publishing or word-processing applications, you are most probably familiar with the concept of styles. Styles are an indispensable tool for formatting documents quickly and efficiently. They allow you to reduce set-up and production time and create documents with a consistent look.

Imagine that you need to format a multipage document that contains different objects, such as paragraph text, artistic text, and graphic elements. If you have to format the document without styles, you need to select each individual object and manually set a number of attributes. For example, you have to select every single paragraph and define attributes such as text alignment, line spacing, and indentation, in addition to character attributes such as font type, size, color, font style, and so on. This process is time-consuming and error-prone because with so many attributes, it is easy to miss a setting.

By contrast, if you use styles and style sets, you can achieve your goal quickly and efficiently.

Styles and style sets are groups of attributes that determine the appearance of objects in your documents: graphic objects, artistic and paragraph text objects, callout and dimension objects, and any objects created with the **Artistic media** tool.

While styles define a particular object property, such as an outline or a fill, style sets, which are collections of styles, control the overall appearance of an object.

An outline style, for example, defines attributes such as outline width, color, and type of line; a character style specifies attributes such as font type, font style and size, text color and background color, character position, caps, and more.

A style set, for example, can consist of a fill style and an outline style that you can apply to graphic objects such as rectangles, ellipses, and curves.

Start by creating styles and style sets that define the appearance of each object in your document. First, create a text style set, consisting of a paragraph style and a character style, to control the appearance of body text.

Next, design separate paragraph styles for headings, or character styles for specific words that you want to highlight. For example, you can define a character style for your company name, so it stands out from the body text.

Then, add outline and fill styles to define the appearance of graphic elements, or if you want

your graphics to share the same fill and outline, create a style set that consists of a fill style and an outline style.

After you create the styles you want, all you need to do is select the objects and apply the respective styles or style sets to format all objects at the same time. This takes a fraction of the time you would otherwise need to format the document manually and also ensures perfect consistency.

There are different ways of working with styles. One option (described above) is to define a style first and then apply it to objects in your drawings; another option is to create an object, format it manually, save it as a style, and then apply the style to other objects. For example, you can add a heading to your drawing and experiment with different settings for font, color, size, and type. When you are happy with the formatting, you can save the character attributes as styles or style sets. Then, you can apply them to all headings in your document. CorelDRAW offers great flexibility and different ways of accomplishing tasks so you can choose the method that best suits your personality and workflow.

In addition to reducing the time for layout and formatting, styles help you quickly make multiple changes to your documents. For example, if you want to increase the font size of all subheadings and make them bold, you don't need to change every single subheading. You simply edit the subheading style. Whether your document contains one page or dozens of pages, all paragraphs with that style will change automatically when you change the style. You can freely and effortlessly try out new designs.

In CorelDRAW, you can create and apply outline, fill, paragraph, character, and frame

styles by using the **Object styles** docker. You can also modify the default properties of the following object types: artistic media, artistic text, callout, dimension, graphic, and paragraph text. You can customize the defaults for your current document, or for all new documents.

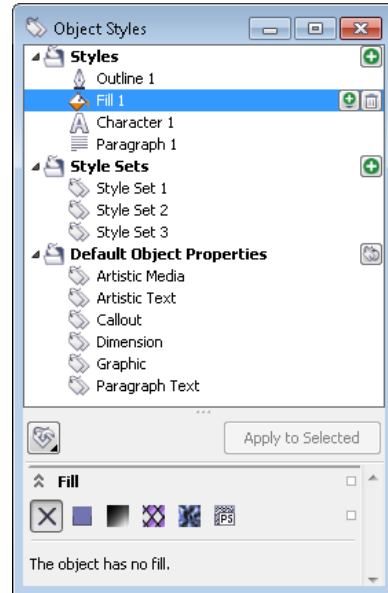

*You create and manage styles and style sets by using the **Object styles** docker.*

Last but not least, styles allow you to achieve consistent formatting not only in one document but across multiple documents. Any styles or style sets that you create are saved with the current document and can also be exported to a style sheet for use in other documents. You can design different style sheets for different projects. As with other features in CorelDRAW, you control how styles work for you. You can easily implement changes across many documents by simply changing the style sheet applied to these documents.

Lorem ipsum dolor sit amet, consectetur adipiscing elit. Integer eget lorem erat, quis lobortis augue. Morbi vestibulum felis vel lorem vehicula in egestas sapien pulvinar. Nunc et erat sed purus auctor elementum. Vivamus aliquet lorem sit amet nisi

Lorem ipsum dolor sit amet, consectetur adipiscing elit

Nullam placerat metus id metus lobortis ultricies

Mauris vel magna ac ligula sagittis tincidunt

Phasellus ut sem nunc, at interdum nisi

Lorem ipsum dolor sit amet,



Lorem ipsum dolor sit amet, consectetur adipiscing elit

Lorem ipsum dolor sit amet, consectetur adipiscing elit. Integer eget lorem erat, quis lobortis augue. Morbi vestibulum felis vel lorem vehicula in egestas sapien pulvinar. Nunc et erat sed purus auctor elementum. Vivamus aliquet lorem sit amet nisi

Lorem ipsum dolor sit amet, consectetur adipiscing elit

Nullam placerat metus id metus lobortis ultricies

Mauris vel magna ac ligula sagittis tincidunt

Phasellus ut sem nunc, at interdum nisi

Lorem ipsum dolor sit amet,



You can quickly change the look of a document by updating the style sheet associated with that document.

Creating styles and style sets

You can create a style or style set based on the formatting of an existing object that you like, or you can create a style or style set from scratch by setting attributes in the **Object styles** docker.

 To create a style based on the attributes of an object, right-click the object by using the **Pick** tool, choose **Object styles** from

the context menu, choose **New style from**, click the type of style you want, and type a name.

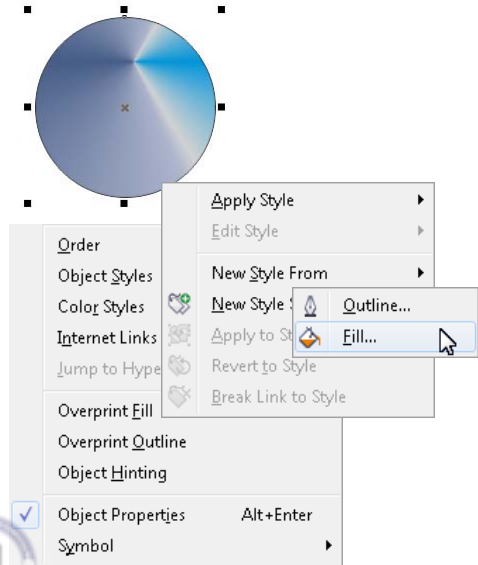

You can save an object fill as a custom fill style.

To create a style set based on the attributes of an object, drag the object from the document window to the **Style sets** folder in the **Object styles** docker, or right-click the object, choose **Object styles**, click **New style set from**, and type a name.

To create a style from scratch, click the **New style** button  in the **Object styles** docker, and click a style type. Specify the settings you want in the style properties area of the **Object styles** docker.

To create a style set from scratch, click the **New style set** button  in the **Object styles** docker to create an empty style set. Drag styles from the **Styles** folder to the new style set.

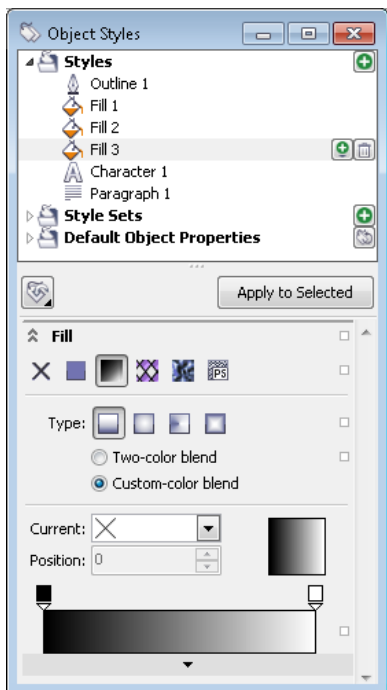



To define a fill style, set the fill attributes in the **Object styles** docker.

In CorelDRAW, styles can contain other styles. A style that contains another style is called a parent; a style that is contained within another style is called a child. Properties are automatically inherited from the parent; however, you can override inherited properties for a child and set its own specific properties. When you modify the parent style, the child style is updated automatically. If you set child-specific attributes, the attributes are no longer related to the parent, so if you modify the parent, the child-specific attributes will not be modified. The parent-child relationship applies to style sets as well.

You can use child and parent styles in documents where you want objects to share some, but not all, attributes, and you need to make global changes on a regular basis. For example, if you are working on a long

document, and you want to have headings and subheadings with similar formatting, you can create a parent character style for the headings and a child character style for the subheadings. The parent and the child styles can share the same color and font type but differ in size. If you choose a different color or font type for the parent, both the headings and the subheadings will be updated automatically. The subheadings, however, will still appear smaller than the headings.

To create a child style or style set, select the parent style or style set in the **Object styles** docker, and click the **New child style** button  or the **New child style set** button .

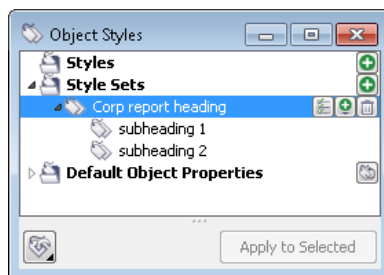

Style sets "subheading 1" and "subheading 2" are created as child style sets from the parent "Corp report heading" style set.

Applying styles and style sets

When you apply a style or a style set to an object, the object takes on only those attributes that are defined in the style or style set. For example, if you apply an outline style, the object outline changes while its other attributes stay the same.

To apply a style or style set to an object, select the object by using the **Pick** tool, and double-click the style or style set in the **Object styles** docker.

You can also apply styles by using the **Object properties** docker.

To apply a style by using the **Object properties** docker, click the source indicator next to an object property (outline, fill, character, paragraph, or frame), and choose a style from the list of available styles.

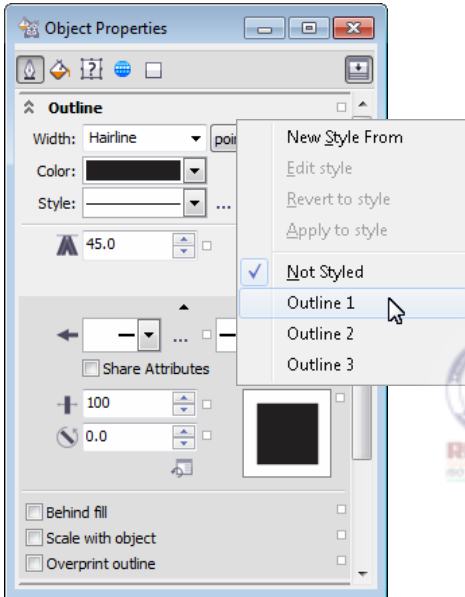

You can apply an outline style by choosing an outline from the list of available styles in the **Objects properties** docker.

Editing styles and style sets

You can edit a style or style set either by modifying its attributes in the **Object styles** docker, or by changing the attributes of an object linked to the style or style set, and then applying these changes to the style or style set.

You can also edit a style or style set by copying attributes from an object to the style or style set.

To edit a style, select it in the **Object styles** docker, and modify its attributes in the style properties area.

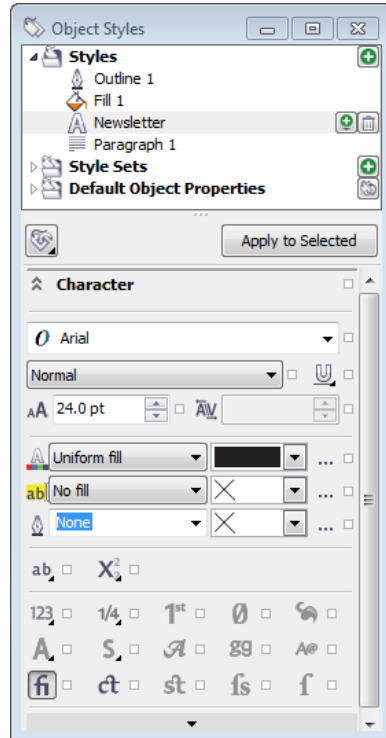

The "Newsletter" character style is selected, and attributes such as font type, color, and size can be modified in the **Character** area.

You can edit a style set by adding or removing styles.

To edit a style set, select it in the **Object styles** docker. Click the **Add or remove style** button  next to the style set, and select a style type. In the style properties area, edit the attributes of the individual style.

To edit a style or style set based on an object, modify the object in the document window, right-click it, choose **Object styles**, and click **Apply to style**.

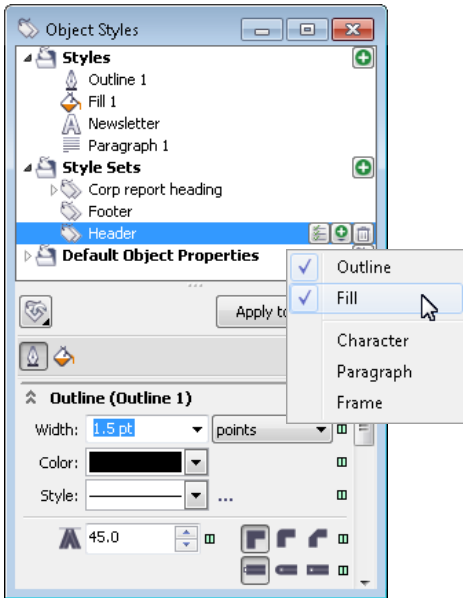

The "Header" style set consists of an outline style and a fill style. You can delete any of the styles or add more styles by clicking a style type.

To edit a style or style set by copying the properties from an object, drag the object from the document window to a style or style set in the **Object styles** docker. Alternatively, you can right-click the style or style set in the **Object styles** docker, choose **Copy properties from**, and click an object in the document window.

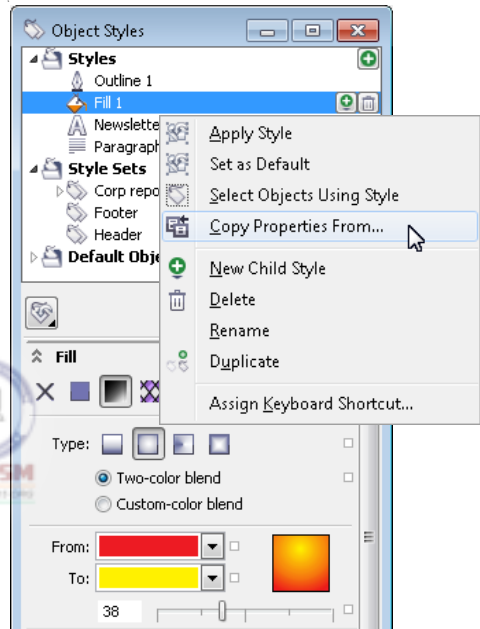

Editing a style by copying properties from an object in the document window

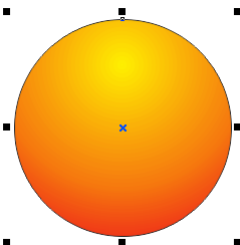
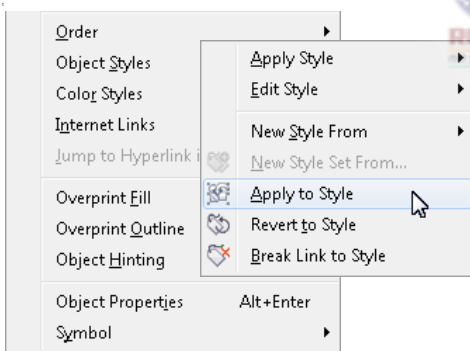

Changing a fill style by modifying an object fill

Exporting and importing style sheets

You can make styles and style sets available for use in other documents by exporting them to a style sheet. A style sheet contains all current styles, style sets, and default object properties from the **Object styles** docker and all color styles from the **Color styles** docker. For information about color styles, see "Working with color styles and harmonies" on page 81.

You can also import style sheets from other documents.

To export a style sheet, click the **Import, export, or save defaults** button  in the **Object styles** dock, and click **Export style sheet**. In the **Export style sheet** dialog box, type a name and choose a location for the style sheet. Then, choose the settings that you'd like to export from the document.

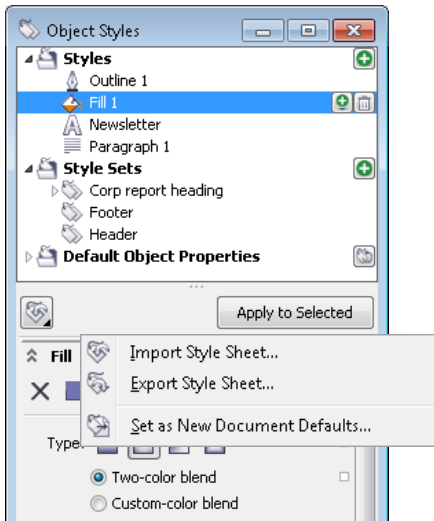

You can export or import style sheets by using the **Object styles** dock.

To import a style sheet, click the **Import, export, or save defaults** button  in the **Object styles** dock, and click **Import style sheet**. Navigate to a style sheet in the **Import style sheet** dialog box, click **Import**, and choose the settings that you want to import.

Finding objects that use a specific style or style set

CorelDRAW allows you to find objects with a specific style or style set in the active

document. For example, you can find all text objects that use a specific heading style.

This is helpful when your drawings contain objects that you often need to modify or redesign. By assigning a style or style set to objects, you can easily select them in one step and modify their properties simultaneously.

To select all objects that use a specific style or style set, right-click the style or style set in the **Object styles** dock, and choose **Select objects using style**.

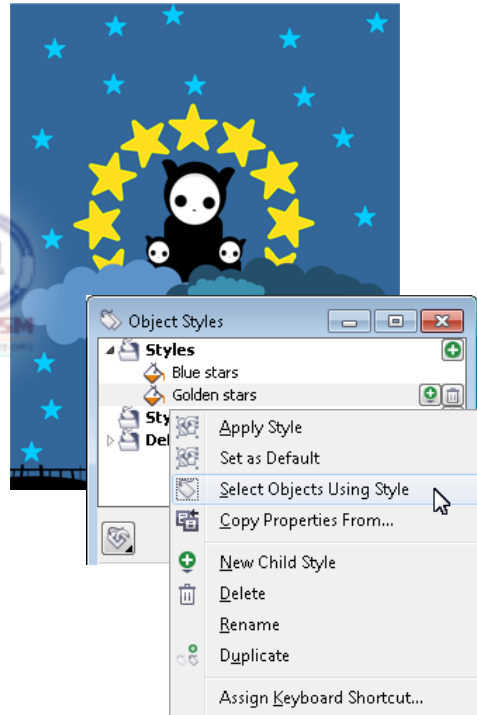

You can quickly locate all objects that are assigned a particular style or style set.

Breaking the link between an object and a style or style set

You can break the link between an object and the style or style set applied to it. When you

break the link, the object retains its current appearance. Subsequent changes to the style or style set will not affect the object.

 To break the link between an object and a style or style set, right-click the object by using the **Pick** tool, choose **Object styles** from the context menu, and click **Break link to style**.

To break the link between a graphic object and the fill style applied to it, click the **Fill** source indicator in the **Object properties** docker, and choose **Not styled**.

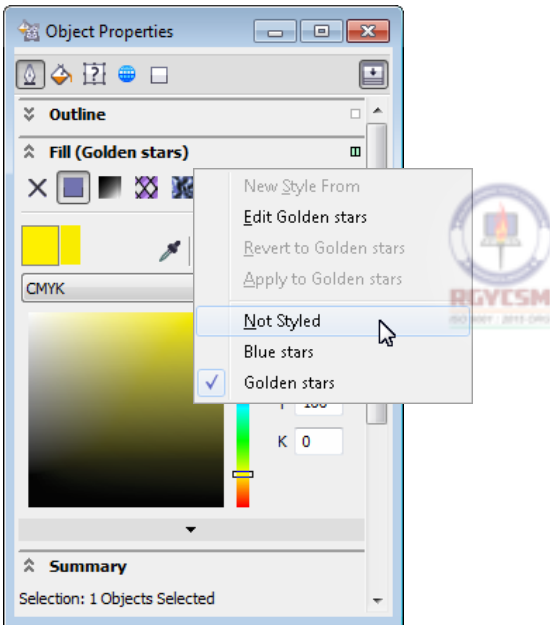

Breaking the link between a graphic object and the fill style applied to it





Image created by
Dhananjay Garg
India

Part Four

Guide to Digital Content



Chapter 10: Finding and Managing Content

Exploring Corel CONNECT **130**

Accessing content **132**

Browsing and searching for content **132**

Using and managing content **134**



Chapter 10: Finding and Managing Content

CorelDRAW Graphics Suite provides an easy way of finding content, such as clipart, photo images, fonts, pattern fills, and frames. When you find the content you need, you can incorporate it into your projects or collect it in a tray for future reference.

Exploring Corel CONNECT

You can browse and search for content by using Corel CONNECT.

 To start Corel CONNECT, click **Start ▶ All programs ▶ CorelDRAW Graphics Suite X6 ▶ Corel CONNECT**.

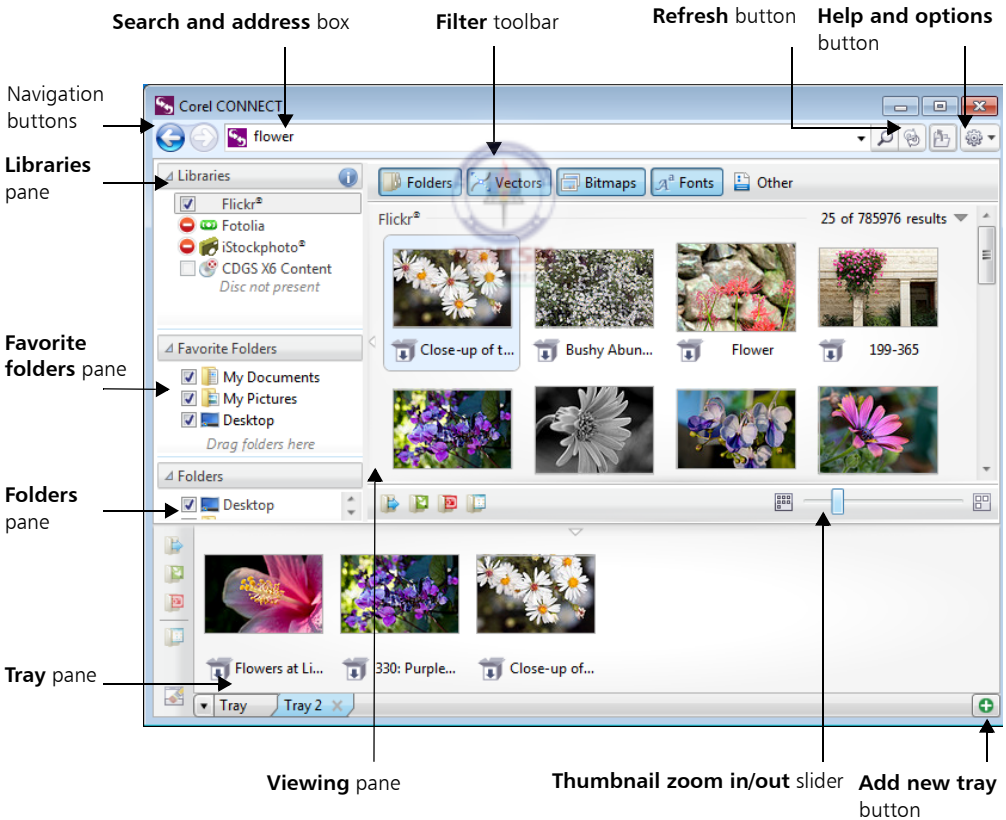

The main components of Corel CONNECT are

- **Libraries** pane — lets you access online and local content provided by Corel and Corel partners
- **Favorite folders** pane — provides quick access to frequently used folders
- **Folders** pane — displays the file structure available on your computer
- **Tray** pane — lets you collect files from one or more folders
- **Viewing** pane — lets you view thumbnails of content files. By positioning your pointer over a selected thumbnail, you can display file information such as filename, file size, resolution, and color mode.
- **Thumbnail zoom in/out** slider — lets you adjust the size of thumbnails in the viewing pane
- **Add new tray** button — lets you create additional trays to organize your content
- **Help and options** button — lets you open a menu of commands that allow you to access Help, configure content libraries, set preferences, and view version and license information
- **Filter** toolbar — lets you choose which type of content to display in the viewing pane: folders, vector images, bitmap images, fonts, or files saved to file formats that are not supported by CorelDRAW Graphics Suite
- **Search and address** box — lets you search for files by using search terms, typing a folder path, or specifying a Web address
- **Navigate back** button — takes you to the previous page of content
- **Navigate forward** button — takes you to the next page of content

Corel CONNECT is available both as a docker and as a standalone application. You can choose whichever mode better suits your workflow. In docker mode, the search utility has two components: **Connect** docker and **Tray** docker.

 To access the **Connect** docker, in CorelDRAW or Corel PHOTO-PAINT, click **Window ▶ Dockers ▶ Connect**.

To access the **Tray** docker, in CorelDRAW or Corel PHOTO-PAINT, click **Window ▶ Dockers ▶ Tray**.

The **Connect** docker has two viewing modes: single pane and full view. In full view, all panes are displayed. In single-pane view, either the viewing pane or the **Libraries**, **Favorite folders**, and **Folders** panes are displayed. You can resize the docker to display all panes or toggle between single pane and full view.

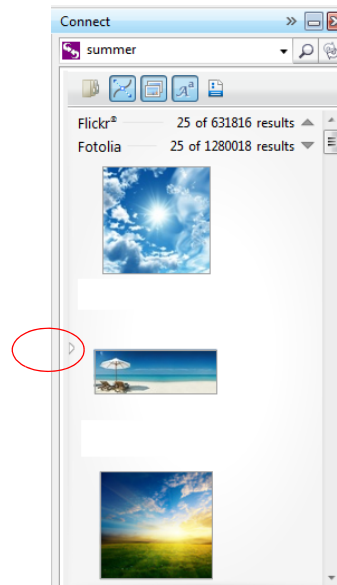

*The **Connect** docker with the viewing pane displayed. Click the toggle arrow to display the navigation pane. Resize the docker to display both panes.*

Accessing content

CorelDRAW Graphics Suite X6 provides a content library that contains clipart, fonts, photos, frames, pattern fills, and more. You can add the library to your computer during product installation to ensure fast and easy access to content from Corel CONNECT, CorelDRAW, and Corel PHOTO-PAINT. The library is copied to the **Public\Public Documents\Corel\Content X6** folder. Alternatively, you can access the version X6 library from the product DVD.

To access clipart and other content included on a CD or DVD from a previous version of the software, you need to insert the CD or DVD, or browse to the folder where you store the content.

You can also find content on the Web sites of online content providers such as Flickr, Fotolia, and iStockphoto.

 To access a content library provided by Corel on a CD or DVD, insert the CD or DVD. The library appears in the **Libraries** pane.

To activate access to local and online content libraries, click the **Configure content libraries** button  in the **Libraries** pane, and follow the instructions in the **Library setup** dialog box.



Library setup dialog box

Browsing and searching for content

You can search by the name, category (for example, clipart, photo images, or fonts), or reference information (for example, tags or notes) associated with a file. When you type a term in the search box and start a search, all matching files are displayed as thumbnail images in the viewing pane. For example, if you type “flower” in the search box, the application filters out all files that do not match the search term, and you see only the files that have the word “flower” in the filename, category, or tags assigned to the file. For information about adding tags and reference information, see “To add drawing information” in the CorelDRAW Help and “To edit document properties” in the Corel PHOTO-PAINT Help.

 To browse for content, click a location in the **Libraries**, **Favorite folders**, or **Folders** pane. You can browse only one location at a time.

To search for content, click a location in the **Libraries, Favorite folders, or Folders** pane. Next, type a word in the **Search and address** box, and press **Enter**.





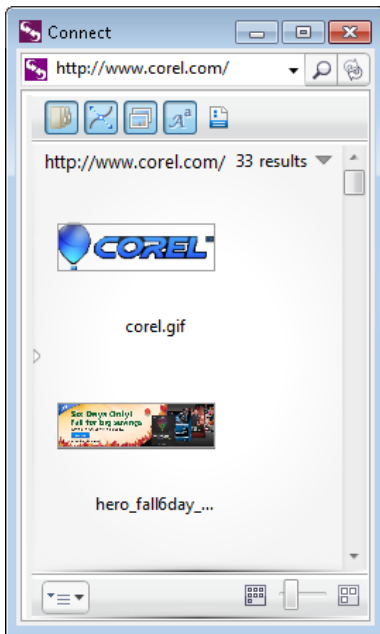

To search for content in multiple locations, enable the check boxes for the folders that you want to search, and click the **Refresh** button .

You can also find all images used on a Web site by typing the Web address in the **Search and address** box.



You can find all images used on a Web site by typing the Web address.

You can narrow the search results by using different criteria, such as graphics type, category, or file format. For example, if you are looking for a vector graphic, you can display only vector formats that are supported by CorelDRAW Graphics Suite. If you are searching for bitmap graphics, you can display only bitmap formats that are supported by CorelDRAW Graphics Suite. If you want to choose a font for the text in your project, you can display TrueType (TTF), OpenType (OTF), and PostScript (PFB and PFM) fonts. You can also search for file formats that are not supported by CorelDRAW Graphics Suite.

 To narrow the search results, click one of the following buttons on the **Filter** toolbar: **Folders** , **Vectors** , **Bitmaps** , **Fonts** , or **Other files** .

 CorelDRAW Graphics Suite is fully integrated with the search capabilities that are offered by Windows 7 and Windows Vista. Note that to use Corel CONNECT on Microsoft Windows XP, you must have Windows Search installed and running. Windows Search is available as a free download from the Microsoft® Download Center. If you are using another third-party computer indexing and search tool (for example, Google Desktop™), or you don't have Windows Search installed, the application has limited search capabilities and lets you search only by filename.

Using and managing content

If you want to view a larger version of a file or edit a file before you incorporate it into your project, you can open it in CorelDRAW, Corel PHOTO-PAINT, or its associated application.

 To open a file, right-click a thumbnail in the viewing pane, and choose the option you want.

For more information about opening files, see “Using content” in the Help.

You can also insert content into your document.

 To insert a file into an active document, drag the file from the viewing pane to the active document.

For more information about inserting content into your documents, see “To insert a file into an active document” in the Help.

The bitmaps and vector graphics (clipart) that you find can be installed as pattern fills for future use.

 To install a pattern fill, right-click the thumbnail of a bitmap or vector graphic in the viewing pane, and click **Install as bitmap pattern** or **Install as vector pattern**.

You can gather content from various folders in the tray. While the files are referenced in the tray, they remain in their original location. You can add and remove content from the tray.

You can create trays to organize your content more efficiently and share it with others. The trays are shared between CorelDRAW, Corel PHOTO-PAINT, and Corel CONNECT.

 To add content to a tray, select one or more thumbnails in the viewing pane, and drag them to the tray.

To create a tray, click the **Add new tray** button in the **Tray** docker. By default, a tray is saved to the **Users\[UserName]\My Documents\Coreel\ Corel Content\Trays** folder.

To rename a tray, right-click the tray tab, click **Rename**, and type a new name.

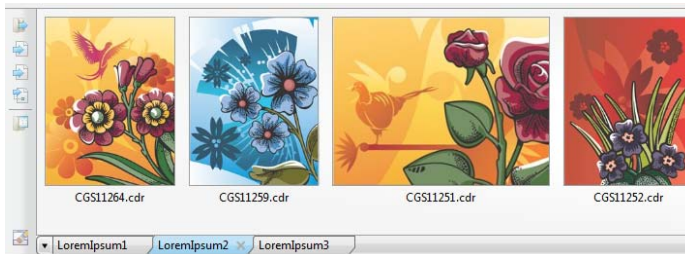

You can organize your content in trays.



Chapter 11: Content Types

Fonts **136**

Symbol fonts **138**

Clipart **140**

Photos **142**

Photo objects **144**

Interactive frames **146**

Patterns **148**

Artistic media **150**

Brushes **152**

Photo frames **154**

Image lists **154**

Chapter 11: Content Types

CorelDRAW Graphics Suite X6 lets you access Corel Content, a vast collection of fonts, symbol fonts, photos, photo objects, interactive frames, patterns, artistic media, brushes, photo frames, and image lists.

Fonts

You can choose from a comprehensive selection of fonts, including premium OpenType fonts. When you find a font that you want to use, you can install it.

 For more information about finding fonts, see “Accessing content” on page 132.

To install a font, right-click a font thumbnail in Corel CONNECT or the **Connect** docker, and click **Install**.



The check mark shows that the font in the middle has been installed.

You can preview fonts that are installed on your computer directly in CorelDRAW or Corel PHOTO-PAINT, or you can browse and organize the available local fonts in the Bitstream Font Navigator.

You can quickly identify the font in a client’s artwork by capturing a sample and sending it to the WhatTheFont™ Web site. For more

information, see “WhatTheFont?!” on page 172.

 To preview available fonts in CorelDRAW or Corel PHOTO-PAINT, click the **Text** tool in the toolbox, and click the **Font** list box on the property bar. The font name appears in the given font.

To display only the fonts used in the document, click the **Text** tool in the toolbox, right-click the **Font** list box on the property bar, and enable the **Show document fonts** option.

To start the Bitstream Font Navigator, from the Windows taskbar click **Start ▶ All programs ▶ CorelDRAW Graphics Suite X6 ▶ Bitstream Font Navigator**.

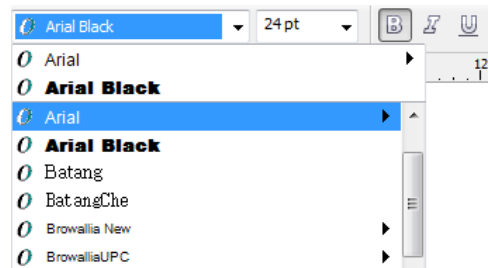

Previewing fonts in the application

Sample fonts

URW Baskerville™ WGL4 BT

Bauer Bodoni™ BT

Lorem ipsum

Lorem ipsum

ClassGarmnd BT

Serifa® BT

Lorem ipsum

Lorem ipsum

Helvetica™

Futura MD BT

Lorem ipsum



Lorem ipsum

Frutiger™ 55 Roman

FuturaBlack WGL4 BT

Lorem ipsum

Lorem ipsum

G4L A03 Nimbus Roman

Nuptial BT

Lorem ipsum

>Lorem ipsum

G1L SC02 Script American

Pica10 BT

>Lorem ipsum

Lorem ipsum

Symbol fonts

Symbol fonts contain special characters that you can insert in your document either as graphic objects or as text objects. You can access a variety of symbols, including international characters, mathematical symbols, currency symbols, calligraphic ornaments, shapes, stars, arrows, and other symbols organized by theme.

 To insert a symbol as a graphic object, click **Text ▶ Insert symbol character**. In the **Insert character** docker, choose a font from the **Font** list box, choose a symbol, and click **Insert**. After inserting the symbol in your document, you can resize, rotate, or reshape it as you would any other graphic object.

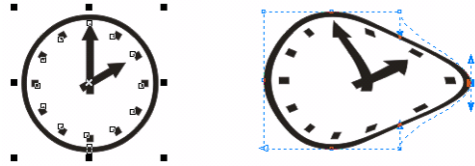

*Distorting a symbol by using the **Envelope** tool*

To insert a symbol as a text object, click the **Text** tool, and click where you want to insert the symbol. Click **Text ▶ Insert symbol character**. In the **Insert character** docker, choose a font from the **Font** list box, choose a symbol, and click **Insert**. The symbol matches the font size of the text and can be edited as a text character.

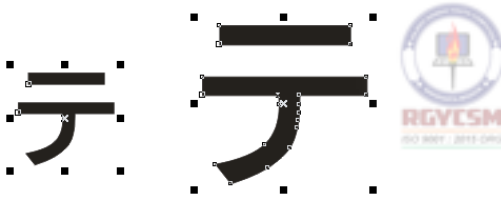

Resizing a symbol

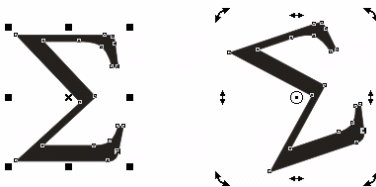

Rotating a symbol

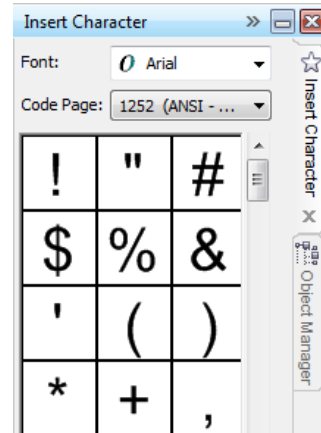

Insert character docker

Lorem  ipsum

Inserting a symbol as a text object

Sample symbol fonts

Animals



Bullets



Chinese Generic I



Japanese Generic I



Korean Generic I



Math with Greek



Nautical Flags

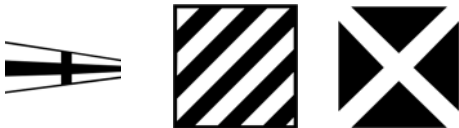

Science



Sign Language



Sports Figures



Symbol Pro BT



Technology



Clipart

CorelDRAW Graphics Suite X6 lets you access a content library that contains thousands of clipart images organized in various categories, such as fashion, ornaments, and vehicle templates. These high-quality vector graphics in CorelDRAW format can be easily searched and adapted for use in your designs.

You can search or browse the various categories of clipart by using Corel CONNECT. For more information, see “Finding and Managing Content” on page 130.

Unlike photos, clipart images are vector graphics. This means that you can freely transform and resize clipart images in CorelDRAW without losing image quality.

 To resize a clipart image, select the image, and drag a selection handle.

To change the colors of a clipart image, select the image, and drag a color swatch

from the color palette to the part of the image that you want to modify.

To break down a clipart image into individual editable objects, select the image, and click **Arrange ▶ Ungroup all**.

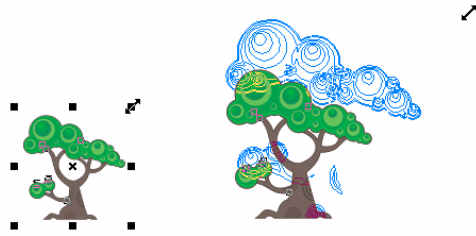

Resizing a clipart image by dragging a selection handle

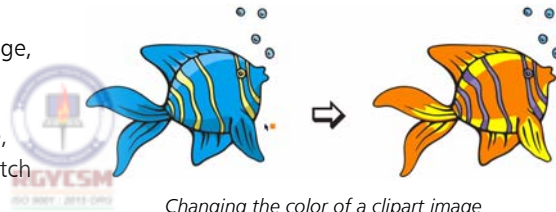

Changing the color of a clipart image



Breaking down a clipart image into individual objects

Sample clipart

Animals



Backgrounds



Birds



Brush Art



Buildings

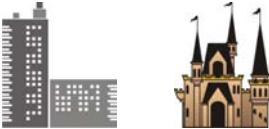

Business



Design Elements



Education



Fashion



Flames



Food



Ornaments



Photos

CorelDRAW Graphics Suite X6 lets you access a selection of high-quality photos on various subjects, such as architecture, landscapes, and travel. The high-resolution images can be easily searched and are suitable for printing.

You can search or browse the various categories of photos by using Corel CONNECT. For more information, see “Finding and Managing Content” on page 130.

Corel PHOTO-PAINT offers comprehensive photo-editing tools that let you crop and stitch images, retouch photos, and adjust color and tone. For more information, see “Editing images” in the Help.

 To change the resolution of a photo that you have imported in CorelDRAW, select the photo, and drag a corner selection handle to resize it. Reducing the size of the photo increases the resolution. The current resolution is displayed on the status bar.

To change the resolution of a photo in Corel PHOTO-PAINT, click **Image ▶ Resample**, and choose the settings you want in the **Resample** dialog box. For more information, see “Changing image resolution” in the Help.

To cut out an area of the image in Corel PHOTO-PAINT, you can use the mask tools. For more information, see “Working with masks” in the Help.



You can make various adjustments to the color and tone of a photo.



*An area of the image is selected with the **Freehand** mask tool.*



The selected image area is cut out from the photo, and feathering is applied to the edges.

Sample photos

Animals



Insects



Landscapes



Nature



Sports



Toys



Transportation



Travel



Food and Drinks



People



Photo objects

Photo objects are bitmap images without a background. They are also referred to as floating objects or cutout images. Unlike photos, photo objects can have various shapes, and you can place them on top of another image without covering up the underlying image. You can select, move, and edit photo objects the way you would any other object. For more information, see “Working with objects” in the Help.

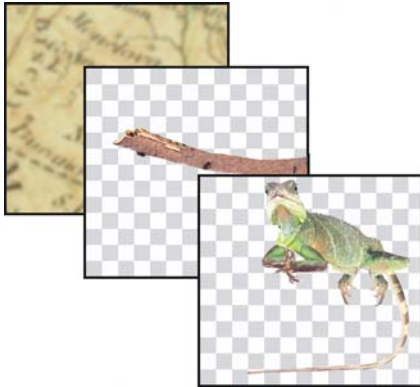

You can stack objects on top of one another.

You can search or browse the various categories of photo objects by using Corel CONNECT. For more information, see “Finding and Managing Content” on page 130.

 To make a photo object fit into the overall image, you can resize it or change its color.

You can create your own photo objects in Corel PHOTO-PAINT. For more information, see “Creating objects” in the Help.



The photo object stands out from the rest of the image.



This image consists of a background and two objects.



The object has been resized, and its color has been changed to create a uniform look and feel for the image.

Sample photo objects

Animal Kingdom



Architecture



Business



Education



Food



Household Objects



Industry



Miscellaneous



Plants



Sports



Toys



Transportation



Interactive frames

CorelDRAW Graphics Suite X6 Content offers interactive frames that you can use for framing graphics and text with CorelDRAW. Interactive frames include PowerClip frames, which are used for graphics content, as well as text frames. You can search or browse the available interactive frames by using Corel CONNECT or the **Connect** docker.

 To add an interactive frame to a document in CorelDRAW, click **Window** ▶ **Dockers** ▶ **Connect** to open the **Connect** docker. In the **Libraries** pane, open the **Corel content** \ **Interactive frames** folder, and then open the **PowerClip frames** or **Text frames** folder. Drag a thumbnail to the drawing window.

For more information about using Corel content, see “Finding and Managing Content” on page 130.

 To add content to a PowerClip frame, drag an object into the frame.

You can also drag content directly into a PowerClip frame from Corel CONNECT or the **Connect** docker.

For more information about PowerClip frames, see “PowerClip frames” on page 206.



An image was added to the PowerClip frame.

 To add text to a text frame, click the **Text** tool, click in the frame, and type the text.

For more information about text frames, see “Text frames” on page 208.

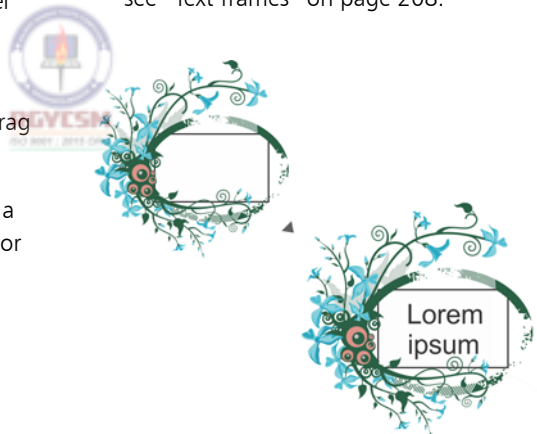

Text was added to the text frame.

Interactive frames



Patterns

CorelDRAW Graphics Suite X6 offers a collection of pattern fills. In CorelDRAW, you can fill objects with two-color, full-color (vector), and bitmap pattern fills.

 To apply a pattern fill to an object in CorelDRAW, select the object, click the **Fill** tool in the toolbox, and then click the **Pattern fill** button on the flyout. In the **Pattern fill** dialog box, choose **2-color**, **Full-color** or **Bitmap**, and choose a pattern fill from the fill picker.



The fill picker lets you choose a pattern fill.

 To apply a bitmap fill to an object in Corel PHOTO-PAINT, select the object, and click the **Fill** tool in the toolbox. On the property bar, click the **Bitmap** button, and then click the **Edit fill** button. In the **Bitmap fill** dialog box, choose a bitmap fill from the fill picker.

You can apply transparencies by using the same pattern fills that you apply to objects.

When you apply a pattern transparency to an object, underlying objects become partially visible.

 To apply a pattern transparency to an object in CorelDRAW, select the object, and click the **Transparency** tool in the toolbox. From the **Transparency type** list box on the property bar, choose **Two-color pattern**, **Full-color pattern**, or **Bitmap pattern**. Choose a pattern from the **Transparency pattern** picker on the property bar.

To apply a pattern transparency to an object in Corel PHOTO-PAINT, select the object, click the **Object transparency** tool in the toolbox, and choose **Bitmap** from the **Fill type** list box on the property bar.

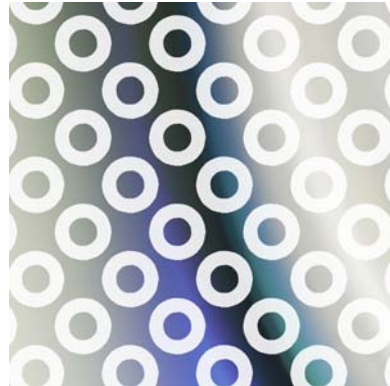

Pattern transparency is applied to the object. The underlying white background is partially visible through the pattern fill.

 For more information about pattern fills, see the Help.

Sample patterns

Full-color patterns



Bitmap patterns

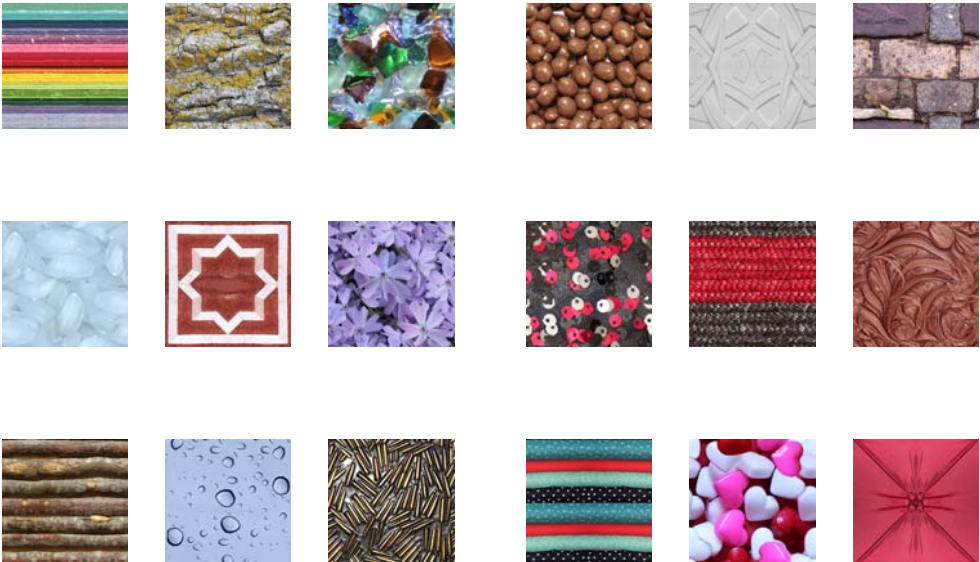

Artistic media

CorelDRAW lets you apply a variety of preset brushstrokes by using the different modes of the **Artistic media** tool. For example, the **Brush** mode lets you draw brushstrokes, and the **Sprayer** mode lets you spray images along a curve. You can also create custom brushstrokes from objects.



Different brushstrokes were used to create this image.

To browse the available brush presets, click the **Artistic media** tool in the toolbox, and click the **Brush** button on the property bar. Choose a brush category from the **Category** list box, and browse the brushstrokes in the **Brushstrokes** list box.

To adjust the width of the brushstroke, type a value in the **Stroke width** box on the property bar.

To spray images along a curve, click the **Artistic media** tool in the toolbox, and click the **Sprayer** button on the property bar. Choose a category from the **Category** list box, choose a spray pattern from the **Spray pattern** list box, and drag in the drawing window.

To create a custom brushstroke from an object, click the **Artistic media** tool in the toolbox, and click the **Brush** button on the property bar. Click the object, and click the **Save artistic media stroke** button on the property bar. Type a name for the custom brushstroke, and click **Save**. The new brushstroke appears in the **Custom** brush category.

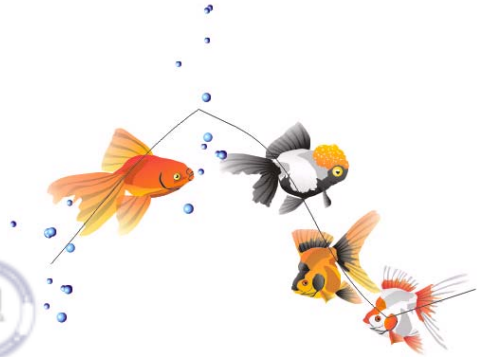

Images sprayed along a curve



A basic shape is used to create a custom brushstroke.

Sample artistic media

Brush presets

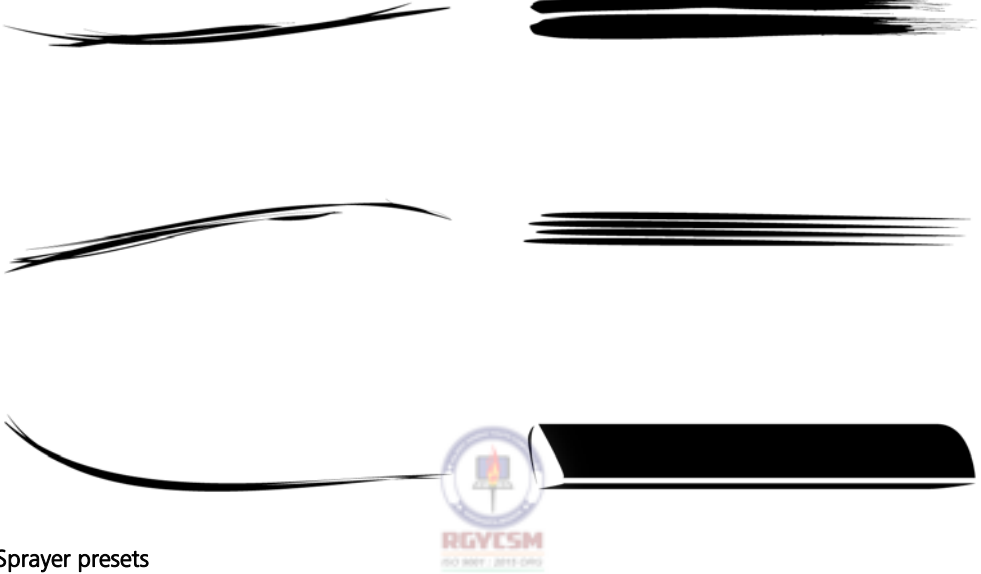

Sprayer presets



Brushes

Corel PHOTO-PAINT lets you apply a variety of preset brushstrokes by using the **Paint** tool. You can paint with art brushes, airbrushes, pens, pencils, crayons, charcoal, pastels, watercolor, and other brushes. For more information, see “Applying brushstrokes” in the Help.

You can also customize the nib properties and stroke attributes of your brushstrokes by using the **Brush settings** docker.

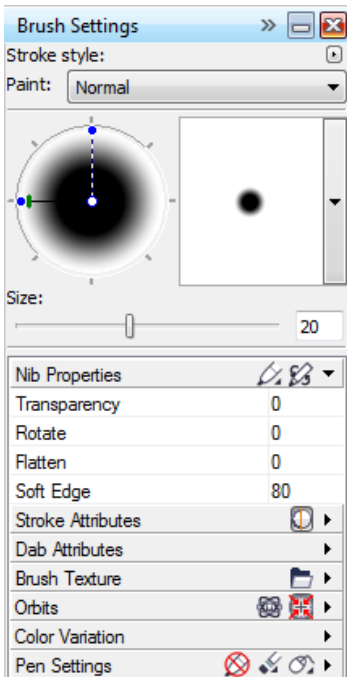

You can customize the nib properties and other brush attributes in the **Brush settings** docker.

For more information, see “Creating custom brushes” in the Help.

 To browse the preset brushes, click the **Paint** tool in the toolbox, choose a brush category from the **Brush category** picker on the property bar, and browse the brushes in the **Brush type** list box.

To change the brush shape, size, or transparency, use the controls on the property bar.

To open the **Brush settings** docker, click **Window** ▶ **Dockers** ▶ **Brush settings**.

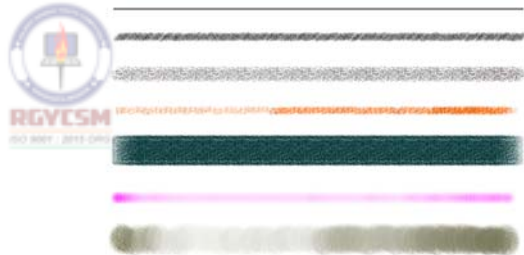

Corel PHOTO-PAINT offers a variety of brushes, including pencils, crayons, charcoals, pastels, and watercolor.

Sample brushes

Meteor



Ash



Angel Hair



Wet Mop



Wet Fan Brush



Emery Cloth



Fox Tail



Feather Duster



Smoke Ribbon



Stix



Tidal Wave



Centipede



Photo frames

CorelDRAW Graphics Suite X6 Content includes a collection of photo frames that you can access from Corel PHOTO-PAINT, CorelDRAW, and Corel CONNECT.

 To frame a photo or another bitmap, click **Effects ▶ Creative ▶ Frame** (Corel PHOTO-PAINT) or **Bitmaps ▶ Creative ▶ Frame** (CorelDRAW). In the **Frame** dialog box, open the frame picker, and choose a frame.



You can choose a frame from the **Frames** picker in the **Frames** dialog box.

 To change the frame color, opacity, edges, and alignment, click the **Modify** tab, and choose the settings you want.





You can customize a preset frame to create an artistic effect.

Image lists

You can paint with small-scale, full-color bitmaps organized in image lists, instead of a brush. For example, you can enhance landscapes by spraying clouds across the sky or foliage across the ground.

CorelDRAW Graphics Suite X6 Content includes a collection of image lists that you can spray with in Corel PHOTO-PAINT.

 To spray images, click the **Image sprayer** tool  in the toolbox, choose a preset image list from the **Brush type** list box on the property bar, and drag in the image window.



Button images were sprayed to decorate the frame.

Sample photo frames

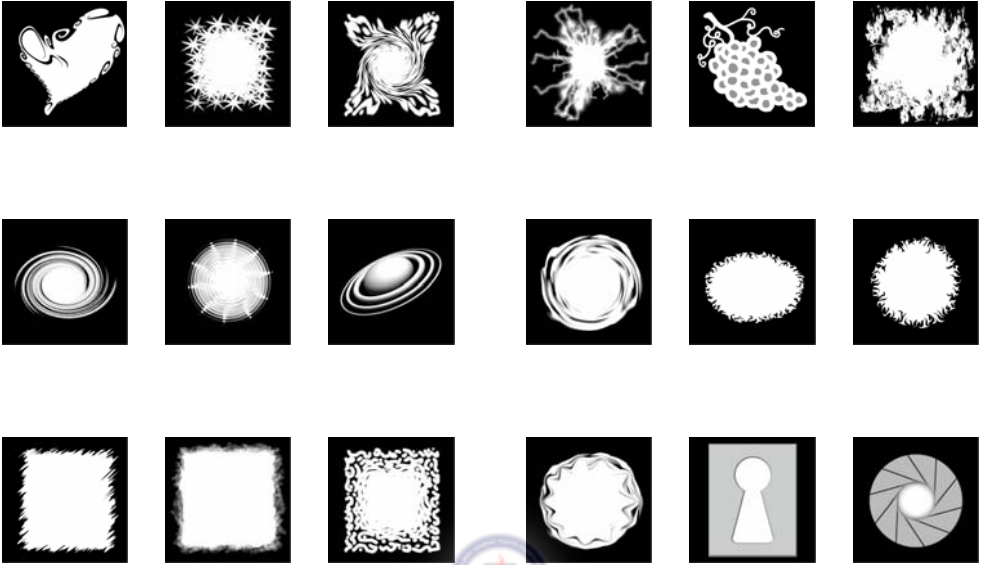

Sample image lists





Chapter 12: Templates

Using preset templates **158**

Modifying template-based documents **160**

Creating templates **162**



Chapter 12: Templates

A template is a collection of styles and page layout settings that control the layout and appearance of a document.

CorelDRAW provides templates that are organized in categories, such as brochures, business cards, and newsletters. You can choose a preset template, modify documents based on preset templates, or create your own templates.

Using preset templates

You can search the available templates by the name, category, designer notes, or other reference information associated with a template. You can also browse local templates. For more information, see “Working with templates” in the Help.

 To create a document from a preset template, click **File ▶ New from template**. In the **New from template** dialog box, search or browse the available templates.

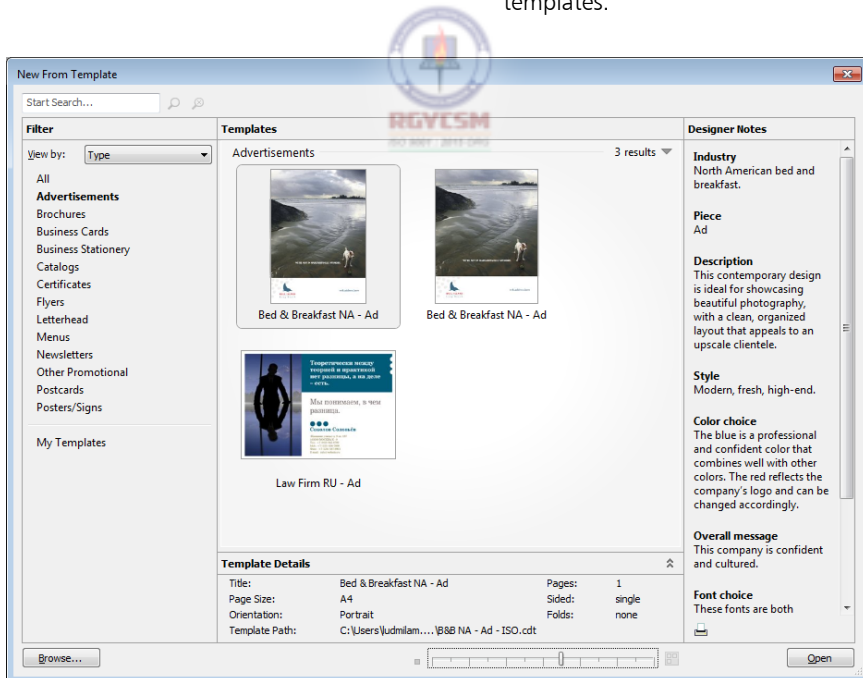

You can browse or search preset templates.



Preset templates represent a variety of industries, products, and design styles.

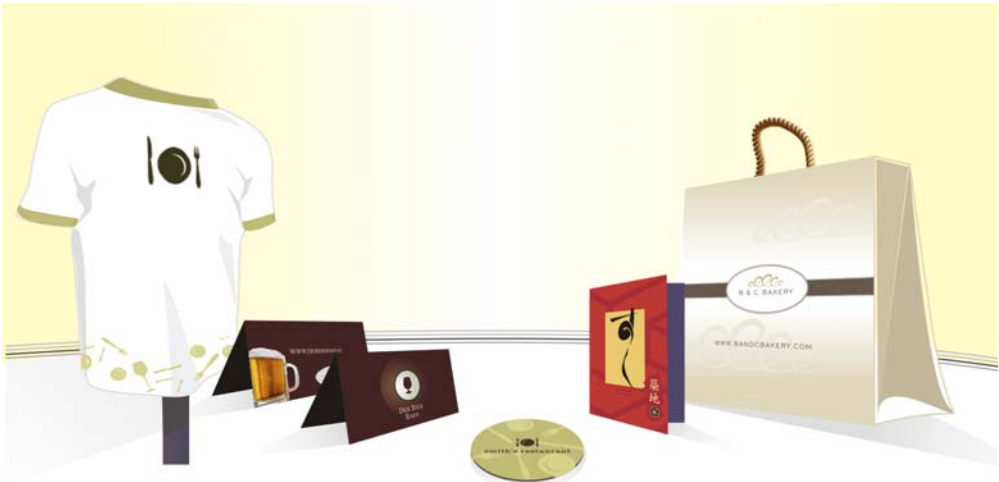

Template categories include T-shirts, coasters, menus, and gift bags.

Modifying template-based documents

You can create a document based on a preset template and then modify the document without affecting the original template.

By making changes to the graphics, text, and layout, you can create a new design to suit your needs. The text and graphics consist of individual objects or groups of objects, which appear in the **Object manager** docker.

You can select, move, edit, or delete any of the objects in your document. For more information, see “Selecting, sizing, and transforming objects” on page 37 and “Coloring and styling objects” on page 38.

In addition, you can easily edit existing text or replace it with your own.

 To edit paragraph text, use the **Text** tool. After selecting the text, you can type new text or change the font, size, color, and other properties of the existing text.

You can also change the page layout of your document, add a background, or insert additional pages. For more information, see “Working with pages” on page 44.

In the following examples, documents created from preset templates are modified to create two unique brochure designs.

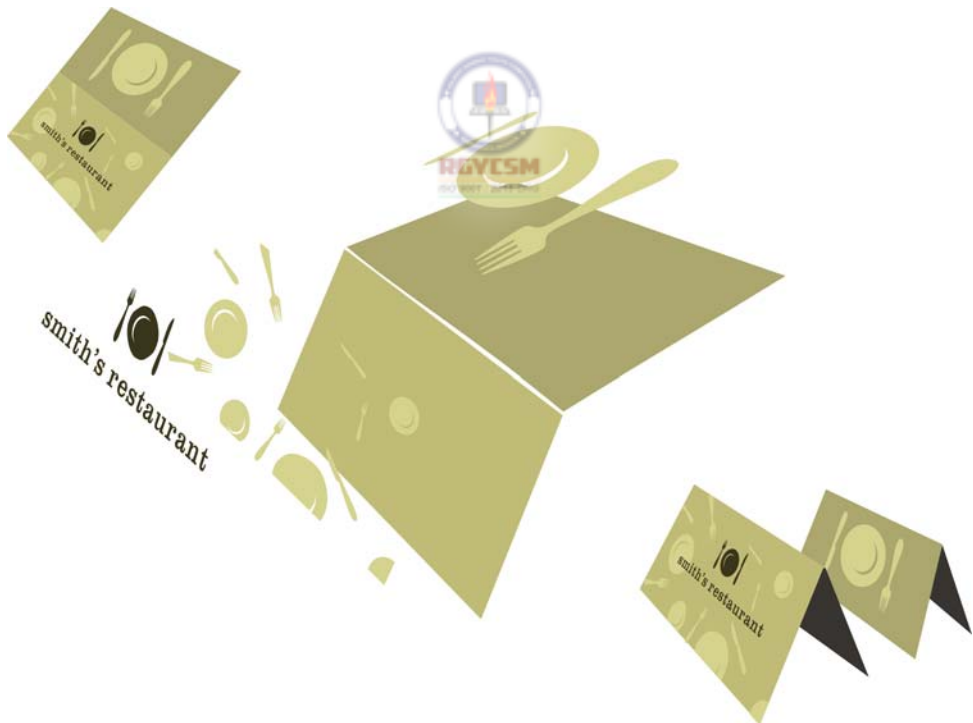

The graphics and text in a template can be edited as individual objects.



Example 1

The following changes are made to the document to create the new brochure:

- 1** — The photos are replaced to reflect the new theme.
- 2** — The color theme of the background is changed to dark blue, red, and light blue, and a new dark blue vector shape is added in the upper-right corner.
- 3** — The square shape on the right is moved, and its color is changed from orange to red.
- 4** — The logo in the upper-right corner is changed.

5 — The main title is updated, and the font is changed to Swiss™ 911 XCM BT.

6 — The blue square shape in the lower middle is moved to the upper-left corner, and the color is changed from light blue to dark blue. The red square shape from the original brochure is deleted.

7 — The secondary headings are updated, and the font color is changed from light blue to red.

8 — The address text is aligned to the left.

9 — A photo frame element is added.

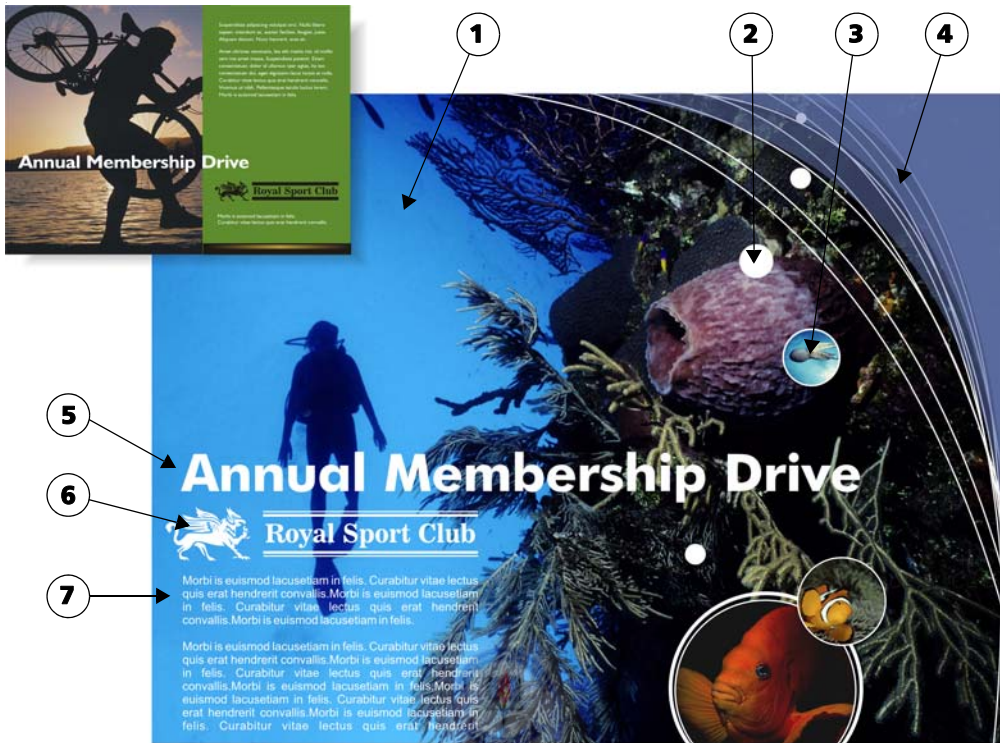

Customizing a brochure from a preset template

Example 2

The following changes are made to the document to create the new brochure:

- 1 — The photo is replaced.
- 2 — White bubbles are created to reflect the theme of the brochure while making the overall composition more whimsical.
- 3 — Additional photos are imported, and PowerClip™ objects are created to make the photos fit within the white vector bubbles.
- 4 — The green backdrop (rectangle) is removed. Purple shapes with subtle white curves are added in the upper-right corner to create balance in the design.
- 5 — The main title is enlarged to span approximately 80% of the page width,

which makes it easier to read the text from afar.

6 — The logo color is replaced with white, and the double horizontal lines are reduced in stroke width.

7 — The body text is relocated under the logo, and the alignment is fully justified, so that the text flows seamlessly.

Creating templates

If you want to reuse the design elements in a document, you can save it as a template.

When you save a template, CorelDRAW lets you add reference information, such as pagination, category, industry, and other notes. This reference information makes it easy to organize and search for templates later.



To save a document as a template, click **File ► Save as template**. Type a name in the **File name** list box, and locate the folder where you want to save the template. Click **Save**. In the **Template properties** dialog box, add any reference information you want.







Image created by
Prem Kumar
India

Part Five

Tips and Techniques





Chapter 13: Sign Making

Scanning a hand-drawn concept **169**

Setting the dimensions or scale **169**

Creating a border **170**

Incorporating and creating content **172**

Getting client approval **177**

Fabricating the sign **178**

Examples **179**

Chapter 13: Sign Making

CorelDRAW® Graphics Suite offers tools and features that let you quickly create effective business signs, banners, vehicle wraps, posters, and more. This chapter introduces you to the most common tasks in the sign-making industry and provides procedures that let you try out the recommended features for each task. The tips and techniques in this chapter were provided by Doug Downey, an experienced sign maker and trainer.

Task	Recommended features
Scanning a hand-drawn concept	Acquire image command
Setting the dimensions or scale	Create a new document dialog box Ruler settings Drawing scale
Creating a border	 Rectangle tool Boundary command Envelope tool
Incorporating and creating content	WhatTheFont?!™ PowerClip™ Align and distribute dialog box Contour tool Bevel effect Drop shadow tool Interactive fill tool Eraser tool Objects docker Image Adjustment Lab
Getting client approval	Color proof settings docker PDF export

Task**Recommended features**

Fabricating the sign

Print dialog box

Scanning a hand-drawn concept

The level of direction that you receive from your client or manager may vary. You may be given a logo or template to work from, or you may have complete creative control. Either way, you should decide on the style of the sign before you begin designing. If you are creating a sign from scratch, you may want to determine the main design elements beforehand. These elements may include font style, border type, color palette, and the use of graphics or photos. You can discuss these design elements with your client or manager to ensure that you share a common vision.

Acquire Image command

CorelDRAW and Corel PHOTO-PAINT

Hand-drawn concepts can be scanned into CorelDRAW or Corel PHOTO-PAINT and used as a reference for your final design. The scanned image can be locked on its own layer so that it is not accidentally moved or edited.

Give it a try

- 1 Click **File ▶ Acquire image ▶ Select source**, and choose a scanner from the list.
- 2 Click **File ▶ Acquire image ▶ Acquire**, and scan the image.
- 3 Do one of the following:
 - In CorelDRAW, select the scanned image in the **Object manager** docker, and click the **Lock or unlock** icon.
 - In Corel PHOTO-PAINT, select the scanned image in the **Objects** docker, and click **Object ▶ Lock**.

The scanned image is locked to prevent editing.

Setting the dimensions or scale

One of the first things you must do is set the drawing scale to reflect the real-world dimensions of the sign that you are creating. Setting the correct drawing scale prevents any sizing or scaling problems when you fabricate the sign later on.

Create a New Document dialog box

CorelDRAW

Before you set a drawing scale, you must choose a unit of measure other than pixels (for example, inches or centimeters). When you create a new document, you can specify the unit of measure in the **Create a new document** dialog box.

Give it a try

- 1 Click **File ▶ New**.
- 2 In the **Create a new document** dialog box, choose a unit of measure other than pixels.

Ruler settings

CorelDRAW

If you have already started a document with pixels set as the unit of measure, you can easily change this preference by using the ruler settings.



Give it a try

- 1 Click **Tools** ▶ **Options**.
- 2 In the **Options** dialog box, expand the **Document** category, and click **Rulers**.
- 3 In the **Units** area, choose a unit of measure other than pixels.

Drawing scale

CorelDRAW

Depending on your own work preferences, you can either choose a preset drawing scale or create a custom drawing scale. Custom drawing scales are useful when your client has provided exact dimensions for the sign and you cannot re-create these dimensions with any of the preset drawing scales.



Give it a try

- 1 Click **View** ▶ **Setup** ▶ **Grid and ruler setup**.
- 2 In the **Document** list of categories, click **Rulers**.
- 3 Click **Edit scale**.
- 4 In the **Drawing scale** dialog box, choose a preset drawing scale from the **Typical scales** list, or create a custom scale by typing values in the text boxes.

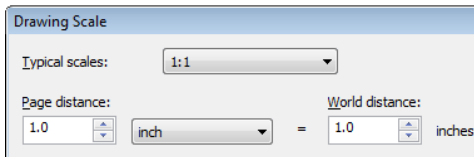

The **Drawing scale** dialog box lets you choose a preset drawing scale or create a custom scale.

Creating a border

When you have set the sign dimensions, you can create a border around your sign. Depending on the look you want, there are various shapes that you can use to create borders.

Rectangle tool

CorelDRAW and Corel PHOTO-PAINT

One of the basic shape tools, such as the **Rectangle** tool, can be used to create a border. The **Rectangle** tool lets you easily modify the look of the corners to create round, scalloped, and chamfered corners, which are often used on signs.



Give it a try

- 1 Click the **Rectangle** tool in the toolbox.
- 2 Do one of the following:
 - In CorelDRAW, type a value greater than 0 in the **Corner radius** boxes on the property bar.
 - In Corel PHOTO-PAINT, click the **Disable fill** button, and type a value greater than 0 in the **Corner size** box on the property bar.
- 3 Use the controls on the property bar to do one of the following:
 - To set round corners for the rectangle, click the **Round corner** button.
 - To set curved notches for the rectangle corners, click the **Scalloped corner** button.
 - To set flat edges for the rectangle corners, click the **Chamfered corner** button.
- 4 Drag to create a rectangular border for the sign.

 In CoreDRAW, double-click the **Rectangle** tool to create a rectangle that matches the size of the page, or click **Layout ▶ Page setup** to add a page frame.

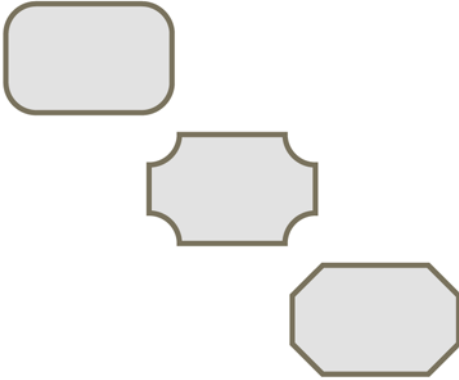

You can create rounded corners, scalloped corners, or chamfered corners.

Boundary command

CoreDRAW

You can use a combination of simple shapes to create a more complex border for your sign. The **Boundary** command in CoreDRAW creates a new object that surrounds the selected objects.

Give it a try

- 1 Using the **Rectangle** tool, drag to draw a rectangle.
- 2 In the toolbox, click the **Ellipse** tool.
- 3 Drag to draw a circle so that it overlaps with the rectangle.
- 4 Using the **Pick** tool, select the circle, hold down **Shift**, and select the rectangle.
- 5 Click **Arrange ▶ Shaping ▶ Boundary**, or click the **Create boundary** button on the

property bar, to create a new object from the two selected objects.

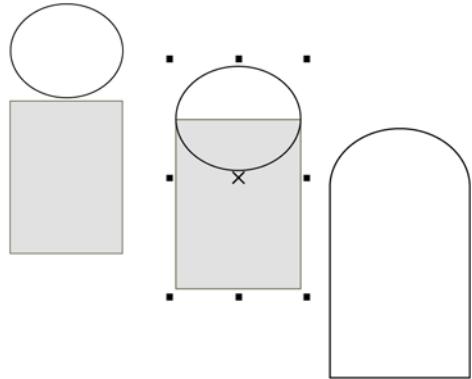

You can use the **Boundary** command to create a complex border from simple shapes.

Envelope tool

CoreDRAW

You can easily add visual effects to your border with the **Envelope** tool in CoreDRAW. The **Envelope** tool lets you interactively warp the sides of an object and create interesting border effects.

Give it a try

- 1 Using the **Rectangle** tool, drag to create a rectangle.
- 2 In the toolbox, click the **Envelope** tool.
- 3 On the property bar, click the **Single-arc mode** button.
- 4 Click the center-top node, hold down **Shift**, and drag the center-bottom node to expand the envelope on both sides.

To apply the effect to one side only, drag a node without holding down **Shift**.

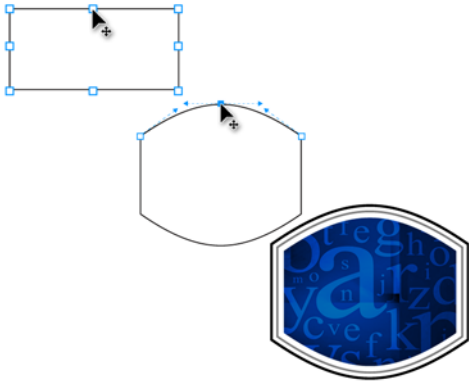

The **Envelope** tool lets you create interesting border effects.

Incorporating and creating content

After designing the border, you can add content to the sign. In some cases, you may have received content from your client, such as a business logo or a tagline. In other cases, you may need to design the content from scratch, beginning with a scanned concept drawing. Here are some useful tools and features to help you quickly and effectively add content to your sign.

WhatTheFont?!

CorelDRAW and Corel PHOTO-PAINT

Your client may send you a font preference for the sign. The client's business brand may require a certain font, or the client may submit several fonts and ask you to create a few samples.

If the file that you receive from your client contains a font that you cannot identify, you can use CorelDRAW or Corel PHOTO-PAINT to access the WhatTheFont?! Web site. WhatTheFont?! lets you capture and submit a font sample for quick and easy identification. (The Web site is available in English only.)

Give it a try

- Do one of the following:
 - In CorelDRAW, click **Text** ▶ **WhatTheFont?!**.
 - In Corel PHOTO-PAINT, click **Object** ▶ **Text** ▶ **WhatTheFont?!**.
- Drag to create a marquee around the font that you want to identify.
- Click inside the capture area, or press **Enter** to complete the capture.

The WhatTheFont?! Web site appears and offers suggestions to help you identify the font.

PowerClip

CorelDRAW

The PowerClip feature in CorelDRAW makes it easy to trim a bitmap image so that it fits within the border of your sign or another vector object.

Give it a try

- Select a bitmap, and position it underneath the vector object.

You can use the **Object manager** docker to make sure that the bitmap is below the vector object in the stacking order, so that the vector object is visible.
- Click **Effects** ▶ **PowerClip** ▶ **Place inside frame**.
- Move the arrow pointer to the object in which you want to place the bitmap image, and click to apply the PowerClip effect.

Right-click the PowerClip object, and choose **Edit PowerClip** to extract the bitmap from the PowerClip container. You can then modify the bitmap or change its position within the container. When you're

done, click the **Stop editing contents button** on the screen or right-click the bitmap, and choose **Finish editing this level**.

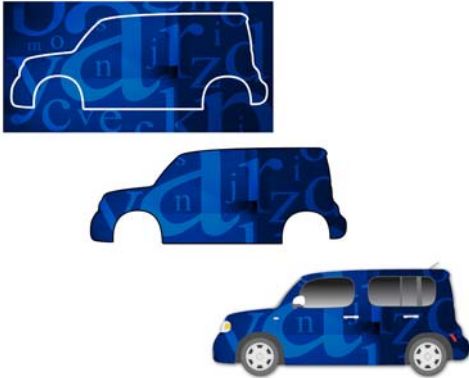

The PowerClip effect lets you trim a bitmap so that it fits within the border of your sign.

Align and Distribute dialog box

CorelDRAW and Corel PHOTO-PAINT

Proper alignment of text and graphic elements is key to the design of any sign, billboard, or car wrap. The **Align and distribute** dialog box can help you align objects to a page, align objects to other objects, or distribute multiple objects evenly at a fixed distance.

Give it a try

- 1 Select two or more objects to align.
- 2 Do one of the following:
 - In CorelDRAW, click **Arrange ▶ Align and distribute ▶ Align and distribute**.
 - In Corel PHOTO-PAINT, click **Object ▶ Arrange ▶ Align and distribute**.
- 3 In the **Arrange and distribute** dialog box, click the **Align** tab.
- 4 Choose options for aligning the objects.

 In CorelDRAW, you can use the following keyboard shortcuts to align the selected objects:

- **C** to align the centers vertically
- **E** to align the centers horizontally
- **T** to align the top of the objects
- **B** to align the bottom of the objects
- **L** to align the left edge of the objects
- **R** to align the right edge of the objects
- **P** to center the objects on the page

Contour tool

CorelDRAW

It is common to apply special effects to text characters or objects in a sign to make them stand out from the background or from other objects.

You can add a contour to text or objects in your design by using the **Contour** tool. The **Contour** tool creates a three-dimensional (3D) effect by creating a series of concentric curves that progress to the inside or outside of an object or text.

Give it a try

- 1 Select an object or text.
- 2 In the toolbox, click the **Contour** tool.
- 3 On the property bar, adjust the size and color of the contour to be applied.
- 4 In the **Contour offset** box, type a value for the distance between contour lines.

At first, try setting a very small offset distance (for example, **0.01"**).

- 5 On the property bar, click one of the following buttons to specify how you would like the contour to be applied to the object: **To center**, **Inside contour**, or **Outside contour**.

 Before you apply additional effects, such as the **Bevel** effect, to the object, click the **Pick** tool, click the contoured object, and click **Arrange ▶ Break contour group apart**. The contour effect must be separated from the object before another effect can be applied.

PortaGravida

PortaGravida



You can use the **Contour** tool to create a 3D effect.

Bevel effect

CorelDRAW

You can use the **Bevel** effect to apply another 3D effect to an object or text. The **Bevel** effect makes your text stand out on the sign and helps draw attention to it.

Give it a try

- 1 Select an object or text.
- 2 Click **Effects ▶ Bevel**.
- 3 Experiment with the different bevel effect settings in the **Bevel** docker.

Drop Shadow tool

CorelDRAW and Corel PHOTO-PAINT

The **Drop shadow** tool produces one of the most powerful effects in CorelDRAW Graphics

Suite and is widely used in the sign-making industry.

This tool lets you add a realistic shadow effect to a selected object, creating the illusion that the object is floating above the sign.

PortaGravida



The **Drop shadow** tool creates a realistic shadow effect.

Give it a try

- 1 Select an object or text.
- 2 In the toolbox, click the **Drop shadow** tool.
- 3 On the property bar, choose a preset, and experiment with the settings to adjust the size, color, and other properties of the drop shadow.

 To adjust the drop shadow interactively, drag one of the square interactive handles.

To change the color of the drop shadow, drag a color from the default or custom color palette to one of the interactive handles. This approach is particularly useful when you want to match a color in your design.

If you have a light-colored drop shadow on a dark background, choose **Normal** from

the **Transparency operation** list box on the property bar to make the shadow stand out more.

To separate the drop shadow from the object or text, select the drop shadow, and click **Arrange ▶ Break drop shadow group apart**.

Interactive Fill tool

CorelDRAW and Corel PHOTO-PAINT

Using the **Interactive fill** tool is a convenient way to create color transitions across an object or text.

Give it a try

- 1 Select an object or text.

In Corel PHOTO-PAINT, click the **Lock transparency** button in the **Objects** docker to constrain the gradient fill to the selected object.

- 2 In the toolbox, click the **Interactive fill** tool.
- 3 Drag across the text or object to apply a color gradient.
- 4 Experiment with the options on the property bar to change the gradient type, color, size, or direction.

 To constrain the gradient direction to 15-degree angles, hold down **Ctrl** while dragging.

To change the start and end colors of the gradient, drag colors from the color palette to the square interactive handles. To add transition colors, drag colors from the color palette anywhere on the dotted line between the interactive handles.



The **Interactive fill** tool creates color transitions across an object.

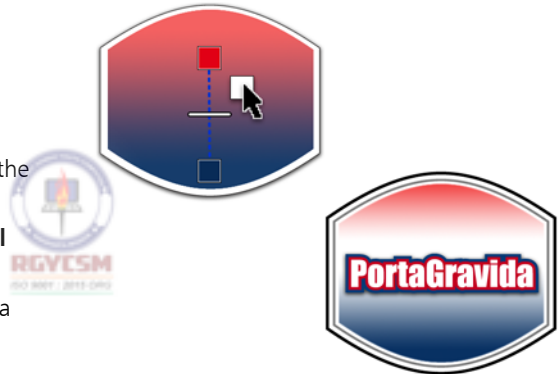

You can add transition colors by dragging colors from the color palette to the dotted line.

Eraser tool

CorelDRAW and Corel PHOTO-PAINT

The **Eraser** tool is great for erasing areas of a design when you don't need to be very precise. For example, you can create various effects by duplicating text and partially erasing the duplicate to reveal the original text underneath.

Give it a try

- 1 Create a text object by using a thick font such as **Impact**.

- 2 Press **Ctrl + D** to duplicate the text, and make sure that the duplicate completely overlaps with the original object.
- 3 With the duplicate selected, do one of the following:
 - In CorelDRAW, click a color on the color palette to change the fill color of the duplicate.
 - In Corel PHOTO-PAINT, right-click a color on the color palette, click the **Fill** tool in the toolbox, and click the letters of the text to change their color.

Changing the color makes it easy to differentiate the top object from the underlying object when you start erasing.

- 4 Make sure that the top object is selected, and click the **Eraser** tool in the toolbox. Erase areas of the top object to partially reveal the underlying text and create various effects.



Gravida



Gravida

The **Eraser** tool lets you create a mountain effect by erasing areas of the top object to reveal the underlying text.

Objects docker

Corel PHOTO-PAINT

You can create interesting layered effects with objects that are on top of your background image in Corel PHOTO-PAINT. The **Opacity** setting in the **Objects** docker lets you adjust

the opacity of the selected object so that elements of the underlying background can become visible. This setting is especially useful when you want to create variation and interest in your sign without making the background too strong.

Give it a try

- 1 Open a bitmap in Corel PHOTO-PAINT.
- 2 In the toolbox, click the **Rectangle** tool.
- 3 Drag to create a rectangle.

The default fill color is black.
- 4 In the **Objects** docker, select the rectangle object.
- 5 Experiment with the **Opacity** setting.



The opacity of the rectangle is adjusted to reveal the underlying background.

Image Adjustment Lab

CorelDRAW and Corel PHOTO-PAINT

The Image Adjustment Lab is an excellent tool that lets you lighten, darken, or make color adjustments to your bitmap images in CorelDRAW or Corel PHOTO-PAINT. You can view the adjustments in the preview window and use the **Create snapshot** feature to experiment with different settings until you are satisfied with the results.



Give it a try

- 1 Select a bitmap image.
- 2 Do one of the following:
 - In CorelDRAW, click **Bitmaps ▶ Image adjustment lab**.
 - In Corel PHOTO-PAINT, click **Adjust ▶ Image adjustment lab**.
- 3 Experiment with the temperature, tint, brightness, contrast, and other settings.
- 4 Click the **Create snapshot** button to save a temporary copy of the image.

Snapshots appear as thumbnails below the image. You can use these thumbnails to compare different settings.

Getting client approval

Before sending your completed sign project for fabrication, you can send a soft proof (usually a PDF) to your client for final approval. By using the color proofing features in CorelDRAW, you can provide your clients or colleagues with a file that is an accurate representation of the colors that will appear on the fabricated sign.

Color Proof Settings docker

CorelDRAW

You can create an accurate proof by exporting a file that contains the color profile of the output device. In addition, you can enable color proofing for your document, which lets you preview how different color profiles will affect the colors in your document.



Give it a try

- 1 Click **Tools ▶ Color proof settings**.
The **Color proof settings** docker appears.
- 2 In the **Color proof settings** docker, enable the **Proof colors** check box.

An icon on the right side of the status bar indicates whether proof colors are turned on or off.

- 3 From the **Simulate environment** list box in the **Color proof settings** docker, choose the color profile for your output.

The display of the document colors on your monitor changes dynamically to let you preview the colors of the final output.

- 4 Click the **Export soft proof** button to save a file with the proof colors.



For more information about color settings and soft proofing, see “Color management settings in CorelDRAW Graphics Suite X6” on page 94 and “Soft proofing” on page 98.

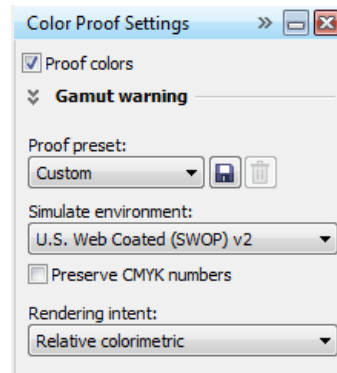

The **Color proof settings** docker lets you choose an output color profile and preview the results.

PDF export

CorelDRAW and Corel PHOTO-PAINT

When you are ready to send your work for approval, you can export your CorelDRAW document to a PDF file, and then e-mail the PDF file to your client. When you export a file, your original CorelDRAW document is unaffected, and a separate copy of your project is created in the selected file format.



Give it a try

- 1 Click **File** ► **Export**.
- 2 Choose **PDF - Adobe portable document format** from the **Save as type** list box.
- 3 Click **Export**.

The **PDF settings** dialog box appears. You can click the **Color** tab to choose specific color settings for the PDF file.



For more information about PDF color settings, see “Specifying color management options for exporting PDF files” in the Help.

Fabricating the sign

When your sign is ready to be fabricated, you can choose from a variety of printers or print service providers. A popular choice in the sign-making industry is a Roland® printer. These printers offer a one-stop printing and cutting experience, eliminating the need to print the sign before sending it to a cutter. Roland printers do all the printing, aligning, and cutting internally, which has made them a top choice among sign makers.

If you have direct access to a Roland printer, you can install the printer driver and print your work directly from your computer. Roland printers come equipped with software that calibrates your image for color and positioning. You can also use the software to position and print multiple copies on the same page, which can reduce the waste of expensive sign material.

If you are sending your work to a print service provider that uses a Roland printer, you can still take advantage of the printer’s one-stop functionality. Roland printers accept multiple file formats, including PDF, EPS, and JPG files. Ask your print service provider whether any specific file formats are preferred.

Print dialog box

CorelDRAW and Corel PHOTO-PAINT

If you are printing directly to a Roland printer, you can set the printer page size and orientation to automatically match the page settings of your CorelDRAW or Corel PHOTO-PAINT file, which eliminates the need to set up the page size and orientation manually. For more information about printing, see “Printing” in the Help.



Give it a try

- 1 Click **File** ► **Print**.
- 2 In the **Print** dialog box, click the **General** tab.
- 3 In the **Page** list box, choose **Match orientation**.

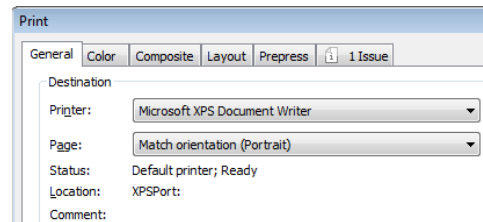

The **Print** dialog box lets you choose page orientation settings.

Examples

The images in this section show business signs that were created by using the features and techniques recommended in this chapter.



Image by Stephan Tetreault



Image by Doug Downey

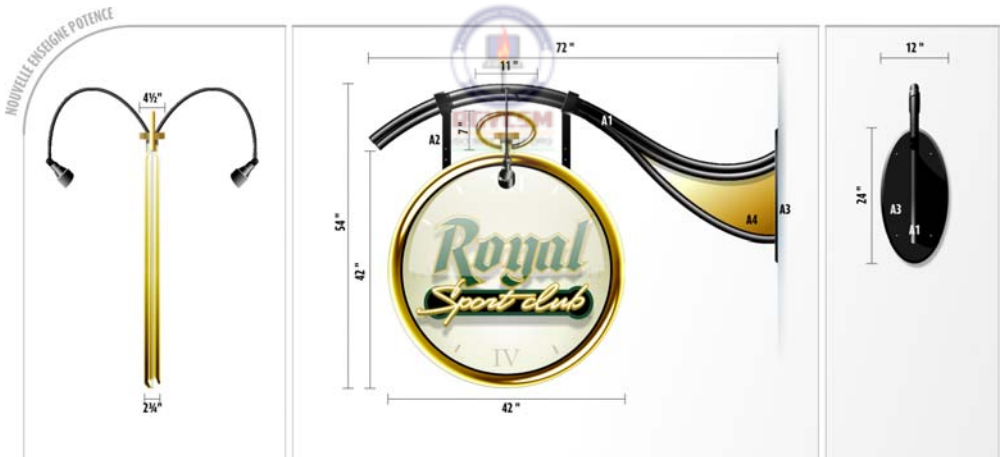



Image by Stephan Tetreault





Chapter 14: Illustration

Setting up the document **183**

Setting up a pen tablet **183**

Sketching by hand **184**

Drawing brushstrokes **184**

Drawing objects **187**

Applying color **191**

Applying effects **194**

Examples **196**

Chapter 14: Illustration

CorelDRAW and Corel PHOTO-PAINT let you unleash your artistic vision to produce stunning illustrations. This chapter introduces you to the most common illustration tasks and recommends features that you can use in your creative workflow. The tips and techniques in this chapter were provided by Igor Tkac, a professional illustrator. Igor's work is featured in the Gallery in Part Seven of this guidebook.

Task	Recommended features
Setting up the document	Create a new document dialog box and Create a new image dialog box
Setting up a pen tablet	Pen tablet settings
Sketching by hand	Paint tool
Drawing brushstrokes	Artistic media tool: Preset mode Artistic media tool: Brush mode Artistic media tool: Sprayer mode Artistic media tool: Calligraphic mode Artistic media tool: Pressure mode Brush settings docker
Drawing objects	Corel® PowerTRACE™ Rectangle tool and Ellipse tool Freehand tool Bézier tool and Pen tool Shape tool Duplicate , Scale , Rotate , and Mirror commands
Applying color	Document palette and Image palette Mesh fill tool

Task**Recommended features**

Applying effects

Transparency tool and **Object transparency** tool**Perspective** effect**Envelope** toolSpecial effects

You can choose from a wide range of drawing tools and special effects to create realistic, photo-quality illustrations, all by hand. CorelDRAW and Corel PHOTO-PAINT both support pen tablet technology, which makes the experience of drawing by hand smooth and intuitive. Even if you do not use a pen tablet, you can create stunning illustrations by using tools such as the **Mesh fill** tool and the **Artistic media** tool.

An illustration can be a bitmap, a vector graphic, or a combination of both. Being able to move smoothly between working with bitmaps and working with vector graphics is key to the successful rendering of the artwork.

Setting up the document

When you start a new file, you must choose settings for the project.

Create a New Document dialog box and Create a New Image dialog box

CorelDRAW and Corel PHOTO-PAINT

The settings that you choose at the start of the project include the dimensions, resolution, color profile, and portrait or landscape orientation. You can change the size and orientation of the project as you work. The resolution and color settings that you choose are based on the intended use of the project. For example, Web designs and print designs

require different settings. For information about setting up your document for different types of output, see “Color Management” on page 90 and “Printing” in the Help.



Give it a try

- 1 Click **File ▶ New**.
- 2 Do one of the following:
 - In CorelDRAW, choose settings in the **Create a new document** dialog box.
 - In Corel PHOTO-PAINT, choose settings in the **Create a new image** dialog box.



Setting up a pen tablet

CorelDRAW and Corel PHOTO-PAINT both support the use of pen tablet technology. Pen tablet hardware consists of a pen and drawing tablet that let you sketch by hand. While you sketch, the software transforms your strokes to look like they were made by various types of pens and brushes. Whether you are drawing complex artwork or simple doodles, the use of a pen tablet is the most intuitive way to transfer the natural hand movements of drawing to the computer screen.

Pen tablet settings

CorelDRAW and Corel PHOTO-PAINT

Both CorelDRAW and Corel PHOTO-PAINT let you customize how your pen tablet strokes are

rendered in your illustration. As you draw with the pen, your unique method of applying tilt and pressure may affect the appearance of the strokes on the screen. To optimize the results produced by your own drawing style, you can automatically adjust the settings according to the pressure that you typically apply to the pen when you draw.

Give it a try

- 1 Click **Tools** ▶ **Options**.
- 2 Do one of the following:
 - In CoreDRAW, expand the **Workspace** list of categories, and click **Display**.
 - In Corel PHOTO-PAINT, click **General** in the **Workspace** list of categories.
- 3 Click the **Configure** button.
- 4 Using a pen tablet, draw a few strokes that represent the pressure that you typically apply.

CoreDRAW and Corel PHOTO-PAINT automatically adjust the pen tablet settings to accommodate your pressure style.

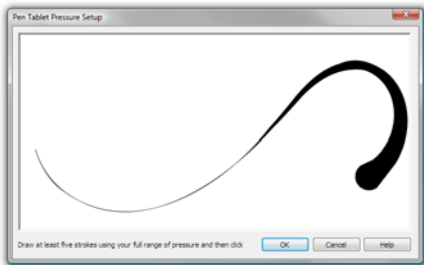

The pen tablet settings automatically adjust the stroke according to the pressure that you apply.

Sketching by hand

Before you begin working with CoreDRAW or Corel PHOTO-PAINT, you may want to sketch

your illustration by hand with a pencil and paper. Sketching by hand can help you visualize the illustration and explore aspects such as perspective, shading, and dimensions. The sketch can then be scanned into CoreDRAW or Corel PHOTO-PAINT and used as a reference when you start drawing and refining your ideas. For more information about scanning the sketch, see “Acquire Image command” on page 169.

Many artists start out by sketching an idea directly in Corel PHOTO-PAINT with a digital pen and tablet. If you use CoreDRAW to finalize the design, creating a sketch with Corel PHOTO-PAINT is a good way to refine the concept before you commit to the vector rendering. The image can then be imported into CoreDRAW at a high resolution (300 dpi or higher).

Paint tool

Corel PHOTO-PAINT

Many artists begin by using the **Paint** tool in Corel PHOTO-PAINT to create a sketch that will be used as a reference throughout their creative process.

Give it a try

- 1 In the toolbox, click the **Paint** tool.
- 2 On the property bar, choose a brush category and a brush type.
- 3 Draw the sketch that you want to use as a reference.
- 4 Click **File** ▶ **Save** to save your file.

Drawing brushstrokes

CoreDRAW and Corel PHOTO-PAINT include a variety of preset brush styles that are inspired

by the textures and brushstrokes in paintings, sketches, and calligraphy. The drawing tools work particularly well with a pen and tablet.

The **Artistic media** tool in CorelDRAW lets you choose from a wide variety of sophisticated preset brush styles. You can draw preset vector shapes, brushstrokes, sprayed images, calligraphic strokes, and pressure-sensitive strokes. For each stroke type that is available with the **Artistic media** tool, you can set preferences for the level of smoothing, the stroke width, and other stroke properties.

With Corel PHOTO-PAINT, you can choose from a variety of preset brushes, or you can use the **Brush settings** docker to modify the brush attributes and create custom brushes.

Artistic Media tool: Preset mode

CorelDRAW

Using the **Preset** mode of the **Artistic media** tool is perfect when you want to create a basic stroke that can be edited. Preset strokes vary in width and shape, and you can edit them by applying a different preset stroke shape, by stretching and moving the stroke on the page, and by applying a fill and outline to the stroke.

Give it a try

- 1 In the toolbox, click the **Artistic media** tool.
- 2 On the property bar, click the **Preset** button.
- 3 Choose a preset from the **Preset stroke** list box on the property bar.
- 4 Draw in the document window.

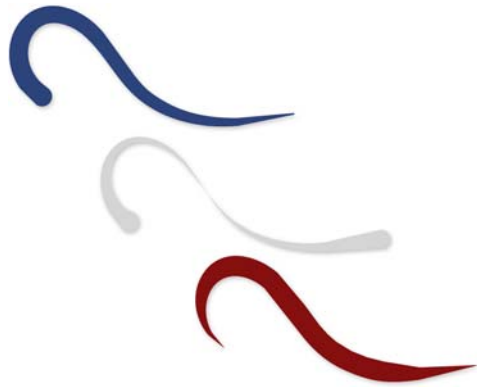

*The **Artistic media** tool presets let you draw basic strokes.*

Artistic Media tool: Brush mode

CorelDRAW

In CorelDRAW, you can choose a brushstroke style from a wide selection of colors, textures, and patterns. You can use brushstrokes to create various painting effects, such as paint splatters, watercolor washes, and oil or acrylic strokes, and you can create other artistic stroke effects that resemble drops of water, a scattering of stars, or a rainbow streak.



*You can create painting effects by using the **Brush** mode of the **Artistic media** tool.*



Give it a try

- 1 In the toolbox, click the **Artistic media** tool.
- 2 On the property bar, click the **Brush** button.
- 3 Choose a brush category from the **Category** list box, and then choose a brushstroke from the **Brushstroke** list box.
- 4 Draw in the document window.

Artistic Media tool: Sprayer mode

CorelDRAW

In CorelDRAW, you can use the **Sprayer** mode of the **Artistic media** tool to add creative elements to your illustration. The tool “sprays” a series of vector images on the page. You can choose from various image types, including fall leaves, beach grass, balloons, and snowflakes.



You can spray vector images along a line.



Give it a try

- 1 In the toolbox, click the **Artistic media** tool.
- 2 On the property bar, click the **Sprayer** button.
- 3 Choose a sprayer category from the **Category** list box, and then choose images from the **Spray pattern** list box.

- 4 Drag in the document window to spray images along a line.



In Corel PHOTO-PAINT, use the **Image sprayer** tool to spray images. For more information, see “Spraying images” in the Help.

Artistic Media tool: Calligraphic mode

CorelDRAW

In CorelDRAW, you can use the **Calligraphic** mode of the **Artistic media** tool to create calligraphy-style strokes on the page. After you draw the calligraphic stroke, you can widen it to create a ribbon effect, or you can stretch, reshape, and fill the stroke.



Give it a try

- 1 In the toolbox, click the **Artistic media** tool.
- 2 On the property bar, click the **Calligraphic** button.
- 3 Adjust the smoothing, width, and angle of the calligraphic stroke by typing values in the boxes on the property bar.
- 4 Draw in the document window.



You can create calligraphic strokes by using the **Artistic media** tool.

Artistic Media tool: Pressure mode

CorelDRAW

In CorelDRAW, the pressure stroke works especially well with a pen and tablet. The stroke thickens as you apply more pressure with the pen and narrows as you release pressure. Try the pressure stroke if you want to re-create the experience of sketching by hand, with the satisfaction of using pen pressure to change the look of the stroke.

Give it a try

- 1 In the toolbox, click the **Artistic media** tool.
- 2 On the property bar, click the **Pressure** button.
- 3 Adjust the smoothing and width of the stroke by typing values in the boxes on the property bar.
- 4 Draw in the document window.

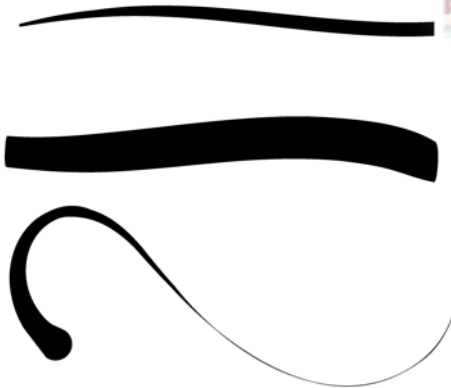

You can use pen pressure to control the look of the stroke.

Brush Settings docker

Corel PHOTO-PAINT

In addition to providing various preset brushes, Corel PHOTO-PAINT lets you create custom

brushes by modifying the brush attributes in the **Brush settings** docker.

Give it a try

- 1 In the toolbox, click the **Paint** tool.
- 2 On the property bar, choose a brush category and a brush type.
- 3 Click **Window** ▶ **Dockers** ▶ **Brush settings**.
- 4 In the **Brush settings** docker, adjust the nib, size, texture, or other brush attributes.
- 5 Draw in the image window.

Drawing objects

CorelDRAW provides a variety of drawing tools that you can use to create and modify shapes. Often, drawing lines is the most time-consuming task in illustration. Many illustrators use CorelDRAW to trace the sketch that they have previously created with Corel PHOTO-PAINT. Various methods can be used to trace the sketch in CorelDRAW. If the original sketch is detailed enough, you can effectively trace it by using Corel PowerTRACE. Alternatively, you can trace the sketch manually — or start an illustration from scratch — by using the **Rectangle** and **Ellipse** tools to create simple shapes, or by using the **Freehand**, **Bézier**, and **Pen** tools to draw lines and curves. After drawing the curves, you can edit and fine-tune their shape by using the **Shape** tool. You can also modify entire objects by scaling, rotating, and mirroring them.

Corel PowerTRACE

CorelDRAW

You can trace a bitmap in one step by using the **Quick trace** command. Or you can choose a suitable tracing method and use the PowerTRACE controls to preview and adjust

the traced results. For more information, see “Tracing bitmaps and editing traced results” in the Help.

Give it a try

- 1 In CorelDRAW, click **File** ▶ **New** to start a new document.
- 2 Click **File** ▶ **Import**, locate the sketch file that you created with Corel PHOTO-PAINT, and click **Import**.
- 3 Click in the document window to position the image on the page.
- 4 With the image selected, click **Trace bitmap** on the property bar, and then choose **Quick trace**.

 To quickly access the **Quick trace** command, right-click the image, and choose **Quick trace** from the context menu.

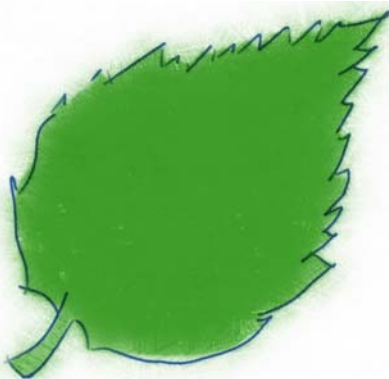

The bitmap sketch, which was created with Corel PHOTO-PAINT, is imported into CorelDRAW.

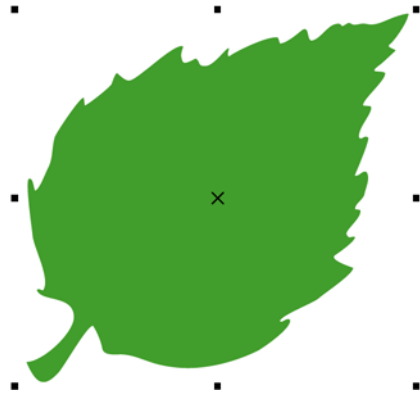

*The leaf is traced by using the **Quick trace** command.*

Rectangle tool and Ellipse tool

CorelDRAW and Corel PHOTO-PAINT

You can draw basic shapes by using the **Rectangle** and **Ellipse** tools, and then modify the shapes to create more complex objects.

With CorelDRAW, you can convert the basic shapes to curves and then edit the curves with more precision.

Give it a try

- 1 In the toolbox, click the **Rectangle** tool or the **Ellipse** tool.
- 2 Drag to draw a rectangle or an ellipse.

 To draw a square, hold down **Ctrl** as you drag with the **Rectangle** tool.

To draw a circle, hold down **Ctrl** as you drag with the **Ellipse** tool.

To convert a basic shape to curves with CorelDRAW, select the shape, and click the **Convert to curves** button on the property bar. After the object is converted to curves, you can use the **Shape** tool to edit and reshape the object.

Freehand tool

CorelDRAW

With CorelDRAW, you can use the **Freehand** tool to trace simple shapes manually. You can control the smoothness of the curves and the number of nodes that are created along the curve.

Give it a try

- 1 In the toolbox, click the **Freehand** tool.
- 2 Drag to draw a curve.

 To adjust the smoothness of the curves, and the number of nodes along the curve, click **Tools** ▶ **Options**. In the **Workspace** list of categories, click **Toolbox**, and then click **Freehand/Bézier tool**. Move the **Freehand smoothing** slider to set the smoothness for curved lines. Higher values produce smoother curves.

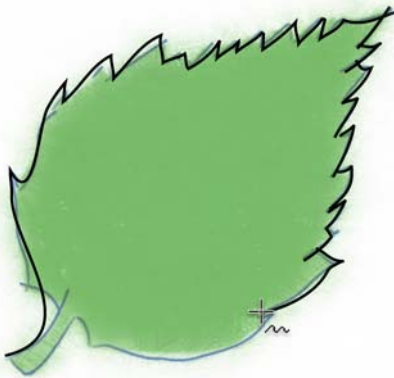

You can use the **Freehand** tool to trace simple shapes.

Bézier tool and Pen tool

CorelDRAW

The **Bézier** tool and the **Pen** tool let you draw lines one segment at a time by placing each

node with precision and controlling the shape of each curved segment. The **Bézier** tool is excellent for creating smooth transitions between curves, and the **Pen** tool lets you alternate easily between straight and curved segments. When using the **Pen** tool, you can preview the line segments before you create them.

Give it a try

- 1 In the toolbox, click the **Bézier** tool or the **Pen** tool.
- 2 Click where you want to place the first node of the segment.
- 3 Do one of the following:
 - To draw a straight segment, click where you want to place the next node.
 - To draw a curved segment, click where you want to place the next node, and without releasing the mouse button or pen, drag to move the control handle and shape the curve. Release the mouse button or pen to finish the segment.

 To close the curve, place the last node on the first node of the curve. You must close the curve on an object if you want to fill the object with color.

To end the line of segments when you use the **Pen** tool, just double-click.

To preview the curve before placing the next node when you use the **Pen** tool, enable the **Preview mode** button on the property bar.

To add a node when you use the **Pen** tool, click the curve where you want to place the node. You can delete a node by clicking it.

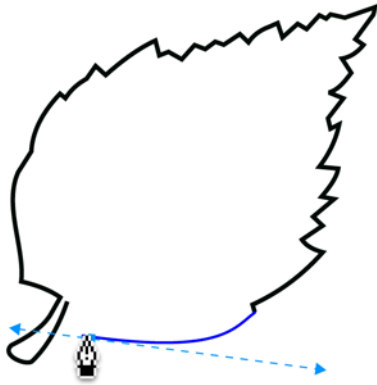

The leaf is drawn by using the **Pen** tool and alternating between straight and curved segments.

Shape tool

CorelDRAW

The **Shape** tool is one of the most important tools in CorelDRAW for creating illustrations. The tool lets you edit the shape of curves by moving a line segment, moving a node, or dragging the control handles to shape a curve segment. The **Shape** tool can be used to modify basic shapes and create more complex objects. It also lets you join nodes and create a closed curve.

Give it a try

- 1 Do one of the following:
 - Draw a curve by using the **Freehand** tool, the **Bézier** tool, or the **Pen** tool.
 - Draw a basic shape by using the **Rectangle** tool or the **Ellipse** tool, and click the **Convert to curves** button on the property bar.
- 2 In the toolbox, click the **Shape** tool.
- 3 Drag a segment, node, or control handle to fine-tune the shape of the curve.

 To convert a straight line segment to a curve, select the node by using the **Shape**

tool, and click the **Convert to curve** button on the property bar.

To add a node, double-click the curve where you want to place the node. To delete a node, double-click it.

To close an open curve, select the curve by using the **Shape** tool, and click the **Auto-close curve** button on the property bar. You must close the curve on an object if you want to fill the object with color.

For information about the different types of nodes, see “Using node types” in the Help.



The **Shape** tool is used to close and reshape a curve before the curve is filled with color.

Duplicate, Scale, Rotate, and Mirror commands

CorelDRAW and Corel PHOTO-PAINT

By duplicating, scaling, or mirroring an object, you can quickly produce multiple copies of the object at different scales. These features let you create subtle differences between multiple objects, which is helpful when rendering items such as hair, leaves, or textures.



Give it a try

- 1 Select the object that you want to duplicate.
- 2 Press **Ctrl + D** to duplicate the object.

When you duplicate an object for the first time, the **Duplicate offset** dialog box appears. You can set the default distance from the original to the duplicate object.

- 3 With the duplicate selected, drag a corner handle inward to reduce the size of the object by 10%.

The percentage of scaling is displayed on the property bar.

- 4 Click the object again to display the rotation handles. Drag a rotation handle to rotate the object by 45 degrees.

The angle of rotation is displayed on the property bar.

- 5 Click **Ctrl + D** to duplicate the rotated object.
- 6 With the duplicate selected, click the **Mirror horizontally** button on the property bar to flip the duplicate from left to right.



To create a copy of the object while you are moving, resizing, or rotating it, press the **Spacebar**.

To create a duplicate object right on top of the original one, press the **+** key on the numeric keypad.

You can repeat transformations that are applied to a duplicate of an object and automatically apply them to subsequent duplicates. Select the first duplicate, and apply any transformations to it. Without deselecting the duplicate, press **Ctrl + D** to create subsequent duplicates with the

same transformations automatically applied. For example, if the first duplicate was scaled down 10% from the original object, each subsequent duplicate will be scaled down 10% from the previous duplicate.



The parts of the leaf are created by duplicating, scaling, rotating, and mirroring duplicate objects.



Applying color

After tracing or drawing your objects, you can apply color to them by using various tools. You can also create effective color blends and transitions to achieve realistic surface and volume.

Document palette and Image palette

CorelDRAW and Corel PHOTO-PAINT

The **Document** palette in CorelDRAW and the **Image** palette in Corel PHOTO-PAINT give you immediate access to the exact colors that are used in your project. The palette is saved with the design, which lets you quickly locate these colors in the future. For more information, see “Using the Document palette, Color Styles palette, and Image palette” on page 84.



Give it a try

- 1 If the **Document** palette or **Image** palette is not displayed, do one of the following:
 - In CoreDRAW, click **Window** ▶ **Color palettes** ▶ **Document palette**.
 - In Corel PHOTO-PAINT, click **Window** ▶ **Color palettes** ▶ **Image palette**.

All colors used in the document or image are automatically added to the palette.

- 2 Click the arrow button in the upper-left corner of the palette to access other options.

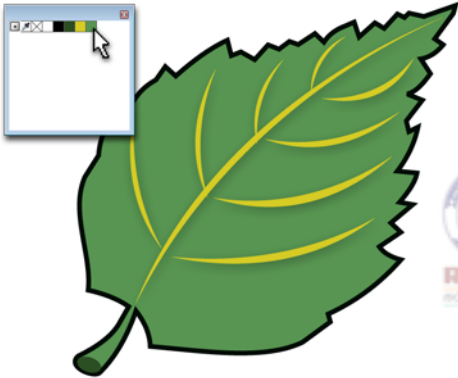

The leaf is filled with green from the **Document** palette.



To prevent colors from being automatically added to the palette, disable the **Automatically update** option.

Click and hold a color on the **Document** palette or **Image** palette to see 49 different shades of that color.

To add a color from an object directly to the **Document** palette or **Image** palette, drag the object to the palette.

To add a color from another color palette within the application, drag the color to the **Document** palette or **Image** palette.

To add colors from anywhere in the window, click the eyedropper button on the **Document** palette or **Image** palette, and click a color.

Mesh Fill tool

CoreDRAW

When creating illustrations, you may find the **Mesh fill** tool particularly useful. The **Mesh fill** tool lets you apply a grid to an object and add colors to the grid to achieve precise color transitions. By adding rows and columns to your mesh grid, you can customize the color transitions from cell to cell within the grid. The more rows and columns you add, the more color transitions you can create. The tighter the individual quadrants are, the more control you have over the blends between the colors. You can also modify the shape of your mesh fill grid by dragging the grid nodes.

The **Mesh fill** tool provides an easy way of creating unique textures and color gradients in your objects without applying multiple blends and contours. By choosing colors close to each other on the color wheel and with similar color values, you can achieve more realistic effects, such as flesh tone or surfaces that require smooth, subtle color transitions. Alternatively, colors farther apart on the color wheel, with radically different values, produce harsher color transitions. Harsh color transitions can be useful for simulating complicated reflections, abstract graphic elements, or materials with

drastic highlights, such as glass or plastics. Layering multiple simple objects with a mesh fill applied to each object can result in more complex and realistic illustrations.

Give it a try

- 1 Select an object.
- 2 In the toolbox, click the **Mesh fill** tool.
- 3 On the property bar, type the number of columns and rows in the **Grid size** boxes.
- 4 Drag the grid nodes on the object to adjust the grid.
- 5 Select a node, and click a color on the color palette to apply the color to the selected section of the grid.

 To add just a tint of color, select a node, hold down **Ctrl**, and click a color on the color palette.

To add a node, click anywhere within the grid, and click the **Add intersection** button on the property bar. To delete a

node, select the node, and click the **Delete nodes** button on the property bar.

A mesh fill can be applied only to an object with a single path. To apply a mesh fill to more complex objects, create the mesh fill on a larger object, and use the PowerClip™ command to position the mesh fill object within the complex shape. For more information, see “PowerClip” on page 172.

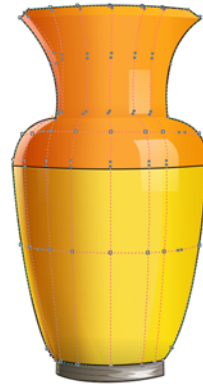

A mesh fill is applied to the vase.

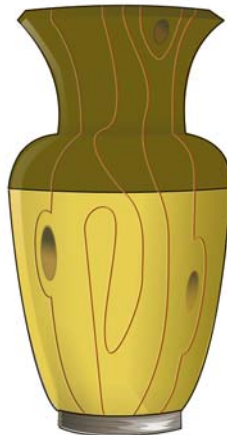

*The **Mesh fill** tool can be used to create smooth color transitions.*

Applying effects

When it's time to apply the finishing touches to your illustration, you can perfect the look and feel of your work by adding special effects with CorelDRAW and Corel PHOTO-PAINT.

Transparency tool and Object Transparency tool

CorelDRAW and Corel PHOTO-PAINT

To add depth to an illustration, you can use the **Transparency** tool if you are working with CorelDRAW, or the **Object transparency** tool if you are working with Corel PHOTO-PAINT. For example, you can apply a gradient transparency to an object that is filled with black and then layer this object on top of a mesh fill in CorelDRAW. This technique adds realistic depth, shading, and highlights to the mesh fill.

Give it a try

- 1 Select an object that is filled with color.
- 2 Do one of the following:
 - In CorelDRAW, click the **Transparency** tool in the toolbox.
 - In Corel PHOTO-PAINT, click the **Object transparency** tool in the toolbox.
- 3 Do one of the following:
 - In CorelDRAW, choose a transparency type from the **Transparency type** list box on the property bar.
 - In Corel PHOTO-PAINT, choose a transparency type from the **Fill type** list box on the property bar.
- 4 Use the controls on the property bar to modify the transparency.



To make the entire object fade, choose the **Uniform** transparency type in CorelDRAW, or the **Flat** transparency type in Corel PHOTO-PAINT.



Transparency is layered on top of the mesh fill to create depth and highlights.

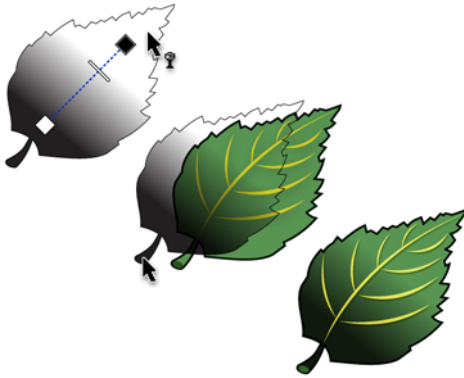

A gradient transparency is applied to the leaf.

Perspective effect

Core/DRAW

You can create a perspective effect by shortening one or two sides of an object. This effect gives the object the appearance of receding in one or two directions, thereby creating a one-point perspective or a two-point perspective.

Perspective effects can be added to individual or grouped objects. You can also add a perspective effect to linked groups, such as contours, blends, and extrusions. Perspective effects cannot be added to paragraph text, bitmaps, or symbols.

Give it a try

- 1 Select an object.
- 2 Click **Effects** ▶ **Add perspective**.
- 3 Drag the nodes on the outside of the grid to change the perspective of the object.

 To move opposing nodes the same distance in opposite directions, press **Ctrl + Shift** as you drag.

To create a one-point perspective effect, press **Ctrl** to constrain the node's movement to the horizontal or vertical axis.

To copy perspective effects to other objects, click the **Attributes eyedropper** tool in the toolbox, click **Effects** on the property bar, and enable the **Perspective** check box.

IPSUM DOLOR



The **Perspective** effect is applied to text.

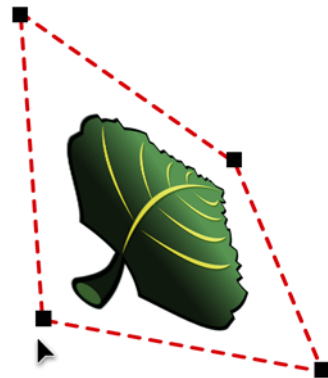

The **Perspective** effect is applied to an object.

Envelope tool

Core/DRAW

Core/DRAW lets you shape objects, including lines, artistic text, and paragraph text frames, by applying envelopes to them. Using the

Envelope tool is a quick and effective way to distort text or shapes and to help define volume. You can use this tool to create objects such as flags, clothes with logos, or complex organic shapes that require lettering or patterns.

Envelopes are made of multiple nodes. You can move these nodes to shape the envelope and the object inside. You can edit an envelope by adding, deleting, and repositioning the nodes. Adding nodes gives you more control over the shape of the object that is contained in the envelope.

Give it a try

- 1 Select an object.
- 2 In the toolbox, click the **Envelope** tool.
- 3 Drag any of the nodes of the envelope.

 Double-click the envelope to add a node, or double-click a node to delete it.



QUISQUAM

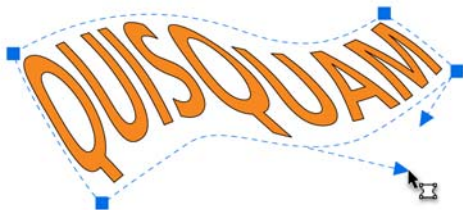

The **Envelope** tool is used to shape text.

Special effects

Corel PHOTO-PAINT

Corel PHOTO-PAINT offers many different effects for bitmap images, including three-dimensional effects, art strokes, lighting effects, and textures.

Give it a try

- 1 Select an object.
- 2 Click the **Effects** menu, and choose a category and an effect to apply to the object.



PortaGravida
QUIA DOLOR SIT AMET



PortaGravida
QUIA DOLOR SIT AMET

You can apply various special effects to objects.

Examples

The images in this section were created by using the features and techniques recommended in this chapter.

More examples of illustrations appear in Part Five, "Insights from the Experts," and on the Gallery pages in Part Seven.



Image by Maurice Beumers (Mo)



Image by Richard Reilly



Image by Igor Tkac



Image by Igor Tkac



A stylized red dragon illustration with intricate scales and flowing mane, set against a solid red background.

Chapter 15: Page Layout

Setting up the document **201**

Adding text **207**

Adding images **212**

Preparing the file for output **216**

Examples **217**



Chapter 15: Page Layout

CorelDRAW and Corel PHOTO-PAINT offer all the tools you need to create compelling page layouts for brochures, newsletters, and other multipage documents. This chapter introduces you to the most common page-layout tasks and recommends features that you can use in your creative workflow. The tips and techniques in this chapter were provided by Rudolfo Bligé, a professional graphic designer.

Task	Recommended features
Setting up the document	Master page Odd-page and even-page master layers Page numbers Guidelines Guideline presets Alignment guides PowerClip frames Layout toolbar
Adding text	Artistic text Text frames Text frames from objects Linked text frames Placeholder text Baseline grid Text on a path
Adding images	File import Shape tool Perfect shapes

Task	Recommended features
	Blend tool Interactive fill tool
Preparing the file for output	Replace wizard Publish to PDF, Export, and Save as commands Collect for output wizard ConceptShare

When you design a document for print, such as a company brochure, your client may provide you with some text copy, a bitmap of a logo, and a general idea of how the elements should be arranged. After you determine the focus of the page design and the main message that the document must communicate, you can make decisions about the arrangement of the design elements, such as the number of columns. If the page layout contains many graphics, you may decide to start with one or two columns. If the page consists mostly of text, a two- or three-column page layout may be more effective.

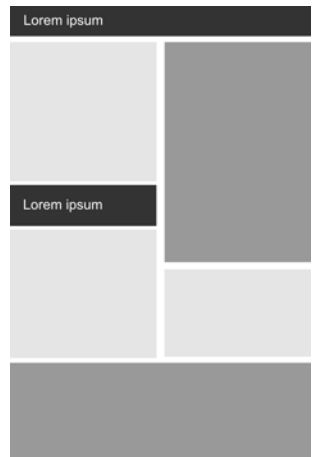

Before you start the design, you can create a rough mockup of your layout and review it with your client.

You can begin by creating a rough mockup. The mockup can consist of basic rectangular blocks that represent the different elements of the design, such as light gray boxes for text, darker gray boxes for images, and black boxes for headlines. Blocking out the content in this way helps you visualize and balance the various elements so that you achieve the proper focus. You can use this mockup to discuss the structure of the design with your client. When you and your client agree on a basic vision for the design, you can get started on the layout.

Setting up the document

After establishing the basic layout structure, you must think about how you will position the design elements. For a multipage layout, you must also consider the elements that will be repeated throughout the document. You can use master layers to set up these repeated elements, and use guidelines to ensure that all elements are consistently aligned.

Master page

CorelDRAW

You can access the master page in the **Object manager** docker. This docker lets you organize the layers of graphics and text in your document.

The master page is a virtual page that contains the information that applies to all pages in a document. You can add one or more layers to the master page (master layers) to hold content such as headers, footers, or a static background. You can also make any layer a master layer.

By default, the master page contains three layers.

- The **Guides (all pages)** layer contains the guidelines that are used for all pages of the document.
- The **Desktop** layer contains objects that are outside the borders of the drawing page. This layer lets you store objects that you may want to include in the drawing at a later time.
- The **Document grid** layer contains the grid that is used for all pages of the document. The grid is always the bottom layer.

The default layers on the master page cannot be deleted or copied.

If you add objects or guidelines to the master page, they will appear on every page that you create.

Give it a try

- 1 Click **File ▶ New**, and choose the settings for the document.

- 2 If the **Object manager** docker is not open, click **Tools ▶ Object manager**.
- 3 In the upper-right corner of the **Object manager** docker, click the flyout button , and choose **New master layer (all pages)**.

When the default layer name appears, you can rename the layer.

- 4 Make sure that the new master layer is selected, and add objects or guidelines to the layer.
- 5 Click **Layout ▶ Insert page**, and choose settings in the **Insert page** dialog box.

The objects and guidelines that you added on the master page appear on the new page.

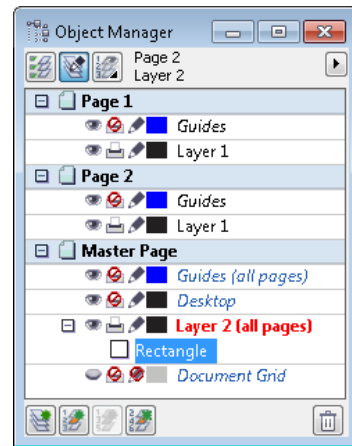

The **Object manager** docker displays all pages and layers. Objects placed on an all-page master layer appear on all pages of the document.

 To add content to a layer, you must first select the layer so that it becomes the active layer.

To make a layer a master layer, right-click the layer, and click **Master (all pages)**.

To change the stacking order of layers on the page, click the **Layer manager view** button in the **Object manager** docker, choose **Current page, layers only**, and drag the layers to reorder them.

Odd-page and even-page master layers

CorelDRAW

In a multipage document, you can create master layers for all pages, for odd pages, or for even pages. For example, placing content on an odd-page master layer means that the content will appear on all odd pages but not on even pages.

Give it a try

- 1 Create a multipage document by clicking **Layout ▶ Insert page** and specifying the number of pages you want.
- 2 If the **Object manager** docker is not open, click **Tools ▶ Object manager**.
- 3 In the **Object manager** docker, click an odd page (for example, Page 1 or Page 3).
- 4 In the upper-right corner of the **Object manager** docker, click the flyout button , and click **New master layer (odd pages)**.

When the default layer name appears, you can rename the layer.

- 5 With the odd-page master layer selected, create an object on the drawing page.

The object appears on all odd pages in the document.

 To create an odd-page master layer, make sure that the active page is an odd page.

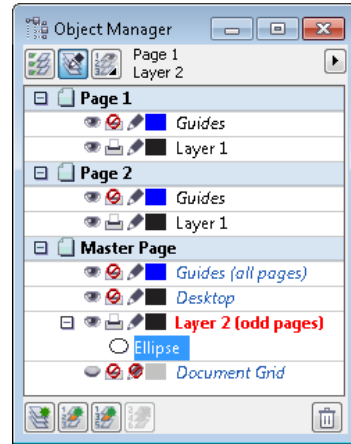

Objects placed on an odd-page master layer (such as the ellipse in this example) appear on all odd pages of the document.

Page numbers

CorelDRAW

You can insert page numbers on the current page, all pages, all odd pages, or all even pages. When you insert page numbers on multiple pages, a new master layer is automatically created, and the page number is placed on it. The master layer can be an all-page master layer, an odd-page master layer, or an even-page master layer.

The following options are available for inserting a page number:

- **On active layer** — lets you insert a page number on the layer that is currently selected in the **Object manager** docker. If the active layer is a master layer, page numbers are inserted on all pages of the document where the master layer is visible. If the active layer is a local layer, the page number is inserted on the current page only.

- **On all pages** — lets you insert page numbers on all pages. The page number is inserted on a new all-page master layer, and this layer becomes the active layer.
- **On all odd pages** — lets you insert page numbers on all odd pages. The page number is inserted on a new odd-page master layer, and this layer becomes the active layer. This option is available only if the active page is an odd page.
- **On all even pages** — lets you insert page numbers on all even pages. The page number is inserted on a new even-page master layer, and this layer becomes the active layer. This option is available only if the active page is an even page.

You can change the default page number settings before or after you insert page numbers in your document. For example, you can start the page count at a specific number other than 1. This is particularly useful if you want to create multiple CorelDRAW files that will be put together as one publication.

You can also specify whether to start page numbering on the first page or on another page. For example, if you choose to start page numbering on page 3, page 3 displays the number 1. If you insert a new page between 1 and 2, it becomes the new page 2, whereas the old page 2 becomes page 3 — the page where the first page number is displayed.

You can manipulate page numbers like any other text object. For example, you can move or resize a page number and change its font or color.



Give it a try

- 1 Click **Layout** ▶ **Insert page number** ▶ **On all pages**.

The page number is centered at the bottom of the page.

- 2 Click **Layout** ▶ **Insert page**, and add a page to your document.

The new page displays the correct page number.

- 3 Click **Layout** ▶ **Page number settings**, and choose one of the following options:

- **Start at number** — lets you start the page count at a specific number
- **Start on page** — lets you specify the page on which to start page numbering
- **Style** — lets you choose from commonly used page number styles



To hide the page number on a single page, click the **Layer manager view** button in the **Object manager** docker, choose **Current page, layers only**, and click the **Show or hide** icon  beside the master layer where the page number object is located.

To change the font, font size, and other text attributes, select the page number with the **Pick** tool, and choose the options you want on the property bar.

To move a page number, drag it to a new location by using the **Pick** tool.

To resize a page number, select it with the **Pick** tool, and drag a corner selection handle.

To change the color of a page number, click a color swatch on the color palette.

Guidelines

CorelDRAW and Corel PHOTO-PAINT

Guidelines are lines that can be placed anywhere in the document window to aid in object placement and alignment.

In CorelDRAW, you can add guidelines to individual pages, or you can add guidelines to the master page if you want to apply them to the entire document. After you add a guideline, you can select it, move it, rotate it, lock it in place, or delete it.

Give it a try

- 1 If the rulers are not displayed, click **View ▶ Rulers**.
- 2 Drag from the horizontal or vertical ruler to the drawing page.

 To select a guideline, click the guideline by using the **Pick** tool in CorelDRAW or the **Object pick** tool in Corel PHOTO-PAINT.

To move a guideline, drag it to a new position. To delete a guideline, select the guideline, and press **Delete**.

To rotate a guideline in CorelDRAW, type a value in the **Angle of rotation** box on the property bar.

To rotate a guideline interactively in CorelDRAW, select the guideline, and then click it once more. Rotation handles and a pivot appear on the guideline. Drag a rotation handle to rotate the guideline, or drag the pivot to change the center of

rotation. To constrain the angle of rotation to 15-degree increments, hold down **Ctrl** while rotating the guideline.

To lock a guideline in CorelDRAW, select the guideline, and click **Arrange ▶ Lock object**.

To make a guideline appear on all pages of a multipage document in CorelDRAW, drag the guideline to the **Guides (all pages)** layer on the master page in the **Object manager** docker.

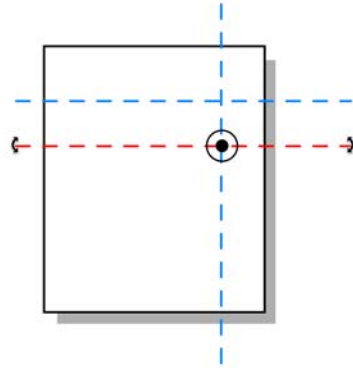

In CorelDRAW, you can display rotation handles by clicking a guideline twice.

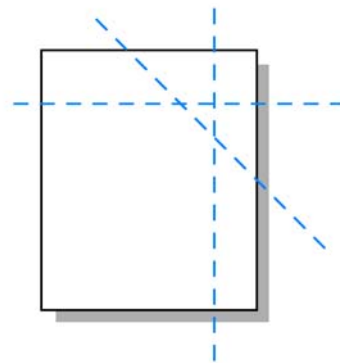

The guideline is rotated by dragging one of the rotation handles.

Guideline presets

CorelDRAW

Although you can drag a guideline from a ruler wherever you need one, you can also use preset guidelines. There are two types of guideline presets: Corel® presets and user-defined presets. Examples of Corel presets include guidelines that appear at 1-inch margins and guidelines that appear at the borders of newsletter columns. User-defined presets are guidelines for which you specify a location. For example, you can add preset guidelines that display margins at a specified distance or that define a column layout or grid.

Give it a try

- 1 Click **Tools ▶ Options**.
- 2 In the list of categories, expand **Document**, expand **Guidelines**, and click **Presets**.
- 3 Choose a Corel preset, or click **User-defined presets**, and set values for the margins, columns, or grid.
- 4 Click **Apply presets**.

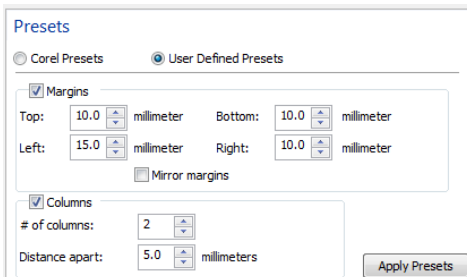

The **Options** dialog box lets you create preset guidelines.

Alignment guides

CorelDRAW

You can align objects interactively on the drawing page by using alignment guides. Alignment guides are temporary guidelines

that appear when you create, resize, or move objects in relation to other nearby objects.

You can easily enable or disable alignment guides, or modify their default settings. For example, you can change the color or add margins. Margins let you align an object at a set distance from the edge of another object.

Give it a try

- 1 Click **View ▶ Alignment guides**.

A check mark beside the **Alignment guides** command indicates that alignment guides are enabled.

- 2 Move an object toward another object.

Alignment guides appear, connecting the center and edges of the objects.

- 3 Click **View ▶ Setup ▶ Alignment guides setup**, and choose the options you want.

To change the color of the alignment guides, choose a color from the **Color** picker.

To add margins to the alignment guides, enable the **Use margins for alignment guides** check box, and type a value in the **Margin** box.



Alignment guides appear when an object is moved.

PowerClip frames

CorelDRAW

CorelDRAW lets you place vector objects and bitmaps, such as photos, inside other objects,

or frames. Any closed object can be used as a frame. When the content is larger than the frame, it is cropped to fit the form of the frame. This creates a PowerClip object (see also “PowerClip” on page 172).

Before you add content to your document, you can define the general structure and composition of the page by creating empty PowerClip frames and text frames to specify the placement of text and graphics. For more information about creating empty text frames, see “Text frames from objects” on page 209.

After you lay out the text and graphics, you can add content to the frames. You can also convert a PowerClip frame back to an object.

Give it a try

- 1 Select the object that you want to use as a frame.
- 2 Right-click the object, choose **Frame type**, and click **Create empty PowerClip frame**.

 To add content, drag an object to the frame.

To convert the frame back to an object, right-click the PowerClip frame, choose **Frame type**, and click **None**.

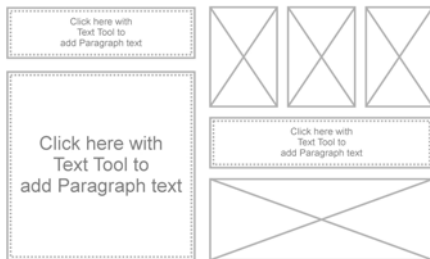

You can use empty frames to lay out text and graphic elements before adding content.

Layout toolbar

CorelDRAW

The **Layout** toolbar gives you quick access to some of the main page layout features, such as text frames, columns, alignment guides, and PowerClip frames.

Give it a try

- Click **Layout** ▶ **Layout toolbar**.

Adding text

With CorelDRAW, you can add two types of text to your layout: artistic text and paragraph text. With Corel PHOTO-PAINT, you can add artistic text only. Artistic text is typically used for short lines of text to which you can apply a wide range of effects, such as drop shadows or contours. Paragraph text, also known as block text, can be used for larger bodies of text that have greater formatting requirements. For example, you can use paragraph text when creating brochures, newsletters, catalogues, or other text-intensive documents.

Artistic text

CorelDRAW and Corel PHOTO-PAINT

You can add artistic text by using the **Text** tool. After creating the text, you can select and modify the entire text object, or only individual characters.

Give it a try

- 1 In the toolbox, click the **Text** tool.
- 2 Click where you want to add text.
- 3 On the property bar, choose a font from the **Font** list box, and choose a font size from the **Font size** list box.
- 4 Type some text.

 To select an entire text object, click the **Pick** tool in CorelDRAW or the **Object pick** tool in Corel PHOTO-PAINT, and click the text object. To select individual text characters, click the **Text** tool, and drag across the text.

To change the default font, click the **Text** tool, and choose a new font from the **Font** list box on the property bar.

To change the position of individual characters in CorelDRAW, click the **Shape** tool in the toolbox, and drag the character nodes to reposition the characters.

To change the properties of artistic text in CorelDRAW, such as kerning or character rotation, select the text with the **Text** tool, click **Text** ▶ **Text properties**, and choose the settings you want in the **Text properties** docker.



In CorelDRAW, you can use the **Shape** tool to change the position of characters in artistic text.

Text frames

CorelDRAW

To add paragraph text, you must first create a text frame. You can create a text frame by using the **Text** tool. By default, text frames have a fixed size, regardless of how much text you add to them. Therefore, any text that continues past the border of the text frame is hidden until you resize the frame. If you want new text frames to adjust automatically to fit the text, you can change the default setting and enable this option.

When designing a page layout that contains both text and graphics, you can wrap text around a graphic within the text frame.

Give it a try

- 1 In the toolbox, click the **Text** tool.
- 2 Drag in the document window to create a text frame.
- 3 Type text inside the frame.

 To resize a text frame, select the frame by using the **Pick** tool, and drag a selection handle.

To set new text frames to adjust automatically to fit the text, click **Tools** ▶ **Options**. In the **Workspace** list of categories, expand **Text**, and click **Paragraph text frame**. Enable the **Expand and shrink paragraph text frames to fit text** check box.

To wrap text around a graphic, right-click the graphic, and choose **Wrap paragraph text**. Using the **Text** tool, drag to create a text frame around the graphic, and type text in the frame. To see more options for wrapping text, select the graphic, and click the **Wrap text** button on the property bar.

Maecenas ultrices facilisis nunc aliquet porttitor. Fusce sed est orci. Donec cursus est sit amet est condimentum dignissim consequat ante sollicitudin. Vivamus ultrices, massa non sollicitudin mollis, nunc dolor rutrum felis, eu volutpat libero felis quis nulla. Fusce eu dolor vitae augue cursus imperdiet a sed massa. Aenean scelerisque semper nisl sit amet luctus. Ut quis nisl ut neque fermentum congue. Maecenas imperdiet, sapien sed congue condimentum, lorem velit dignissim risus, sed eleifend neque dolor eu augue. Donec non dolor nibh. Proin varius fringilla mi, vitae porttitor magna iaculis interdum. Pellentesque malesuada consequat quam, ut sollicitudin purus tempor in. Vestibulum vitae sem fringilla lectus fringilla hendrerit. Fusce arcu ante, ultricies gravida tempor quis, tempus ut mauris. Integer nec gravida nisi. Proin bibendum porttitor nisl eu sodales. Morbi eget orci dui, in ultricies neque. Maecenas neque lacus, bibendum sed aliquet vulputate, tincidunt eu mauris. Vivamus dignissim



Text is wrapped around a graphic.

Text frames from objects

CorelDRAW

You can create text frames from objects, which increases the number of different shapes that you can use as text frames. In addition, text frames of various shapes and sizes can help you visualize the page layout before you add content to your document.

When you create a text frame from an object, the frame is empty. You can add text to the frame, or you can convert the text frame back to an object. In addition, you can separate the text frame from the object, so that they can be moved or modified independently.

Give it a try

- 1 Draw a closed shape.
- 2 Right-click the object, choose **Frame type**, and click **Create empty text frame**.

The object is converted to a text frame.

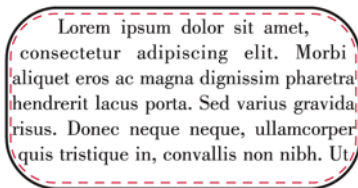

An object converted to a text frame

 To add text to the text frame, click the **Text** tool, and type inside the frame.

To convert the text frame back to an object, right-click the text frame, choose **Frame**

type, and click **None**. If the frame contains text, a warning that the contents of the frame will be lost is displayed.

To separate the text frame from the object, select the object by using the **Pick** tool, and click **Arrange** ▶ **Break paragraph text inside a path apart**.

Linked text frames

CorelDRAW

When creating a page layout, you may want to link multiple text frames so that the text flows between them continuously as you make adjustments to the page layout. The advantage of linking text frames is that you do not have to worry about accidentally cutting off the text as you resize the text frames. Linked text frames can be especially useful if your layout contains columns.

Give it a try

- 1 Select the starting text frame by using the **Text** tool.
- 2 Click the **Text flow** tab at the bottom of the text frame.

If the frame cannot hold all the text, the tab contains an arrow, and the outline of the text frame is red instead of black.

- 3 Move the pointer to the frame or object into which you want to continue the text flow. When the pointer changes to a black arrow, click to link the two frames.

If the frame or object is on a different page, first click the corresponding **Page** tab on the document navigator.

 To link text frames by using the **Text** menu, select the frames, and click **Text** ▶ **Paragraph text frame** ▶ **Link**.

To break the link between text frames, select the frames, and click **Text** ▶ **Paragraph text frame** ▶ **Unlink**.

To create a linked frame on another page with the same size and position as an existing frame, click the **Text flow** tab at the bottom of the first frame, click the corresponding **Page** tab on the document navigator, and hover over the area of the drawing page that corresponds to the position of the first frame. When a preview of the frame appears, click to create the linked frame.

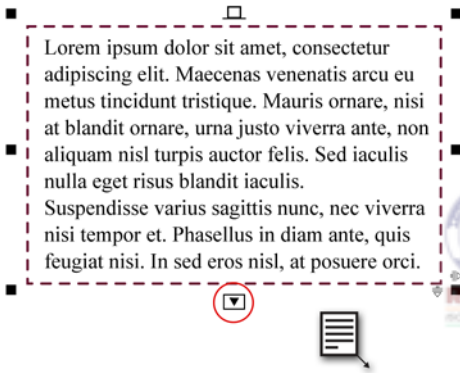

When you click the **Text flow** tab at the bottom of the text frame, the pointer changes.

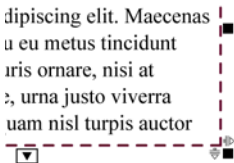

When you point to another text frame or object, the pointer changes to a black arrow.

piscing elit. Maecenas eu metus tincidunt is ornare, nisi at urna justo viverra am nisl turpis auctor

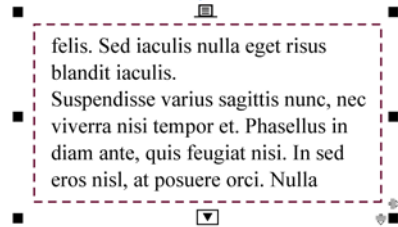

The blue arrow shows that the two text frames are linked and indicates the direction of the text flow.

Placeholder text

CorelDRAW

If you want to see the general layout of your document before you add the final content, you can fill the text frames with temporary placeholder text. You can format placeholder text just like any other text, or create custom placeholder text.

Give it a try

- Right-click an empty text frame, and click **Insert placeholder text**.

To create custom placeholder text, save your text in a word-processing application as placeholder.rtf, and place the file in the following folder:
My Documents\Corel\Corel Content.

Baseline grid

CorelDRAW

You can align text within a frame or in different text frames by using the baseline grid. This is

useful, for example, when you want to align two or more text frames that contain different fonts, font sizes, or spacing.

The guides of the baseline grid run across the drawing page and follow the pattern of a ruled notebook. You can change the grid color and line spacing. By default, the line spacing is 14 pt.

You can set one or more text frames to align to the baseline grid.

Give it a try

- 1 Click **View ▶ Grid ▶ Baseline grid**.

A check mark beside the **Baseline grid** command indicates that the baseline grid is displayed.

- 2 Select a text frame, and click **Text ▶ Align to baseline grid**.

- 3 Move the text frame away from and then toward the drawing page.

As long as part or all of the text frame overlaps with the drawing page, the text is aligned with the baseline grid. When the text frame is moved completely outside the drawing page, the text returns to its original alignment.

 To change the color and line spacing of the baseline grid, click **View ▶ Setup ▶ Grid and ruler setup**. In the **Baseline grid** area, type a value in the **Spacing** box, and choose a color from the **Color** picker.

Text on a path

CorelDRAW and Corel PHOTO-PAINT

You can fit artistic text to the path of an open object (for example, a line) or a closed object

(for example, a square). In CorelDRAW, you can also fit paragraph text from a text frame to an open path. If the text frame is inside an object, it must be separated from the object before the text can be fitted to a path.

After you fit text to a path, you can adjust the orientation or position of the text in relation to the path, as well as other text properties. With CorelDRAW, you can mirror the text horizontally or vertically, or both. You can also specify spacing increments for snapping text to the path, which is called tick spacing. With Corel PHOTO-PAINT, you can mirror text by placing it on the inside or outside of the path.

CorelDRAW treats text fitted to a path as one object; however, you can separate the text from the path. When you separate text from a path, the text retains the shape of the path. You can straighten the text so that it reverts to its original appearance.

Give it a try

- 1 Create a path by doing one of the following:

- In CorelDRAW, create an object by using the **Rectangle** tool or **Ellipse** tool, or draw a curve by using the **Freehand** tool, **Bézier** tool, or **Pen** tool.

- In Corel PHOTO-PAINT, create a path by using the **Path** tool, or create a mask by using the **Rectangle mask** tool or the **Ellipse mask** tool, and then click **Mask ▶ Create ▶ Path from mask**.

- 2 Do one of the following:

- In CorelDRAW, select a text object or a text frame by using the **Pick** tool.
- In Corel PHOTO-PAINT, select a text object by using the **Object pick** tool.

- 3 Do one of the following:
 - In CoreDRAW, click **Text ▶ Fit text to path**.
 - In Corel PHOTO-PAINT, click **Object ▶ Text ▶ Fit text to path**.

The pointer changes.

- 4 Move the pointer over the path.

In CoreDRAW, you can preview where the text will be fitted.

- 5 Click where you want to place the text.

If the text is fitted to a closed path, the text is centered on the path. If the text is fitted to an open path, the text flows from the point of insertion.

- 6 Adjust the text's orientation, distance from path, mirroring, and other properties by using the controls on the property bar.

 To separate text from a path in CoreDRAW, select the text, and click **Arrange ▶ Break text apart**. To straighten the text, make sure that the text is selected, and click **Text ▶ Straighten text**.

To specify tick spacing in CoreDRAW, select the text by using the **Pick** tool, click **Tick snapping** on the property bar, enable tick snapping, and type a value in the **Tick spacing** box.

To type artistic text directly on a path in CoreDRAW, select the path by using the **Pick** tool, and click **Text ▶ Fit text to path**. A text cursor is inserted directly on the path. To type text on a path in Corel PHOTO-PAINT, click the **Text** tool, and move the pointer over a path. When the pointer changes, click where you want the text to begin.

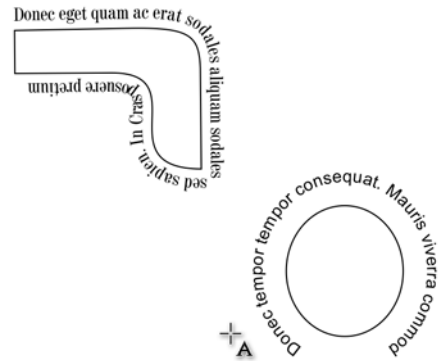

You can fit text to a path so that the text follows the outline of an object.

Adding images

By using graphic elements, you can add interest and draw attention to the main message of your design.

File import

CoreDRAW and Corel PHOTO-PAINT

You can import files that were created in other applications. For example, you can import TIFF, JPEG, PNG, and Adobe® Illustrator® (AI) files.

When you import a file, it is placed in the active application window as an object. You can resize or center a file as you import it.

Give it a try

- 1 Click **File ▶ Import**.
- 2 Navigate to the folder that contains the file to be imported.
- 3 Select the file, and click **Import**.
- 4 Click where you want to place the file.

If you want to resize the image as you import it, drag in the document window.

If you want to center the image on the page, press **Enter**.

- To import multiple consecutive files, hold down **Shift**, and click the first and last files. To import multiple nonconsecutive files, hold down **Ctrl**, and click the files individually to select them.

Shape tool

Core/DRAW

With Core/DRAW, you can remove the background from a bitmap image by using the **Shape** tool. The **Shape** tool lets you reshape the boundary of the bitmap to exclude areas without deleting them.

Cutting out the background from an image makes the foreground subject stand out and can help integrate the graphic more effectively within your page layout.

Give it a try

- 1 In the toolbox, click the **Shape** tool.
- 2 Select the bitmap.
- 3 Drag a corner node inward to reshape the bitmap boundary.
The area outside the boundary is removed.

- To add a node, double-click the bitmap boundary. Having more nodes lets you shape the image with greater precision. Double-click a node to delete it.

To convert a straight line segment to a curve, click the node, and click the **Convert to curve** button on the property bar. Drag the control handles to reshape the curve around the bitmap image.

To restore the image area that was removed, simply drag the nodes outward to their original position.

To cut out parts of the image permanently and reduce the file size of the bitmap, use the **Crop** tool. For more information, see “Cropping, splitting, and erasing objects” in the Help.



The image background is removed by using the **Shape** tool.

Perfect shapes

Core/DRAW

Using the Perfect Shapes collection, you can draw predefined shapes, such as arrows, banners, and callouts. Some shapes contain diamond-shaped handles that are called glyphs. You can use the glyphs to modify the appearance of a shape.

Give it a try

- 1 In the toolbox, click one of the following tools:
 - **Basic shapes**
 - **Arrow shapes**
 - **Flowchart shapes**

- **Banner shapes**
- **Callout shapes**

- 2 On the property bar, choose a shape from the **Perfect shapes** picker.
- 3 Drag to draw a shape in the document window.

 To modify a shape that has a glyph, drag the glyph by using the **Shape** tool.

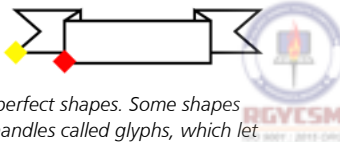
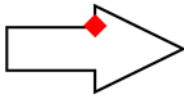

You can create various perfect shapes. Some shapes have diamond-shaped handles called **glyphs**, which let you modify the shape.

Blend tool

CorelDRAW

CorelDRAW lets you create blends between objects, such as straight-line blends, blends along a path, and compound blends. A blend follows a progression in shape, size, and color from one object to another through a series of intermediate objects.

After you create a blend, you can fit the objects from the blend along a new path, or you can add one or more objects to a blend to create a compound blend.

Give it a try

- 1 In the toolbox, click the **Blend** tool.
- 2 Select the first object, and drag from this object to the second object.

If you want to reset the blend, press **Esc** as you drag.

 To create a freehand blend path between two objects, hold down **Alt**, and drag to draw a freehand path from the first to the second object.

To fit a blend to a new path, click the blend by using the **Blend** tool, click the **Path properties** button on the property bar, and choose **New path**. Using the curved arrow, click the path to which you want to fit the blend.

To stretch the blend over an entire path, select a blend that is already fitted on a path, click the **More blend options** button on the property bar, and enable the **Blend along full path** check box.

To create a compound blend, use the **Blend** tool to drag from an object to the starting or ending object of a blend.



The heart shape is blended along the path of the circle.

Interactive Fill tool

CorelDRAW and Corel PHOTO-PAINT

You can use the **Interactive fill** tool to add fountain fills to objects. A fountain fill, also known as a gradient fill, is a smooth progression of two or more colors that adds depth to objects. You can add intermediate colors anywhere in the fill's progression.

You can apply different types of fountain fills, such as linear, radial, conical, and square.

- A **linear** fountain fill flows in a straight line across the object.
- A **radial** fountain fill radiates from the center of the object.
- A **conical** fountain fill creates the illusion of light hitting a cone.
- A **square** fountain fill is dispersed in concentric squares from the center of the object.



Give it a try

- 1 Select the object that you want to fill.
In Corel PHOTO-PAINT, click the **Lock transparency** button in the **Objects** docker to constrain the gradient fill to the selected object.
- 2 In the toolbox, click the **Interactive fill** tool.
- 3 On the property bar, choose one of the following from the **Fill type** list box:
 - **Linear**
 - **Radial**
 - **Conical**
 - **Square**
- 4 Do one of the following:
 - In CorelDRAW, choose the starting and ending colors for the gradient fill from

the **First fill color** and **Last fill color** pickers on the property bar.

- In Corel PHOTO-PAINT, choose the starting and ending colors for the gradient fill from the **Fill style** list box on the property bar.



To change a color in the gradient, drag a new color from the color palette to one of the color nodes. In CorelDRAW, you can also select the color node and choose a color from the **Fountain fill node color** picker on the property bar. In Corel PHOTO-PAINT, double-click a color node to open the **Node color** dialog box, and choose a color.

To add an intermediate color, drag a color from the color palette to the dotted line between two colors.

To adjust the color transitions, drag the midpoint marker or any of the color nodes.

To delete an intermediate color in CorelDRAW, double-click the color node.

To delete an intermediate color in Corel PHOTO-PAINT, right-click the color node, and click **Delete**.

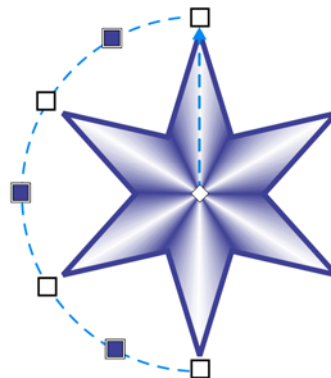

A conical fountain fill that is applied to a star creates the illusion of a three-dimensional object.

Preparing the file for output

When your page layout design is finished, you must prepare the file for output.

Replace wizard

CorelDRAW

The **Replace** wizard guides you through the process of finding objects that contain the properties you specify and then replacing those properties with others. You can replace such properties as fill colors, outline properties, and text attributes, such as font and font size. You can also replace color models and palettes — for example, you can replace all RGB colors with CMYK colors. For more information about color models and color palettes, see “Color Basics” on page 72.

Give it a try

- 1 Click **Edit** ▶ **Find and replace** ▶ **Replace objects**.
- 2 Follow the steps in the wizard.

 To replace RGB colors with CMYK colors, choose the **Replace a color model or palette** option, and click **Next**. On the next page of the wizard, enable the **Find a color model** option, and choose **RGB** from the list. Make sure that the **Replace with the color model** option is set to **CMYK**. Choose any other options you want, and click **Finish**.

Publish to PDF, Export, and Save As commands

CorelDRAW and Corel PHOTO-PAINT

CorelDRAW and Corel PHOTO-PAINT let you export documents as PDF files. A PDF file can be viewed, shared, and printed on any

platform provided that the person viewing the PDF has Adobe Acrobat, Adobe Reader, or another PDF-compatible reader installed. With CorelDRAW, you can export either the entire document, or only selected objects.

CorelDRAW and Corel PHOTO-PAINT offer several different ways of creating PDF files. You can use any of the following commands:

Publish to PDF, **Export**, and **Save as**. The **Publish to PDF** option lets you quickly publish a file to PDF without specifying any options or making decisions about the output. You can choose from several PDF presets, which automatically apply specific settings for you. For example, with the Web preset, the resolution of the images in the PDF file is optimized for the Web. You can also create your own PDF presets or edit existing presets. The **Export** and **Save as** commands let you fine-tune your output by using the options in the **PDF settings** dialog box.

For more information about PDF export, see “Exporting to PDF” in the Help.

Give it a try

- Do one of the following:
 - For quick PDF export, click **File** ▶ **Publish to PDF**, and choose a preset from the **PDF preset** list. Browse to the folder where you want to save the file, type a filename in the **File name** box, and click **Save**.
 - For advanced PDF settings and options, click **File** ▶ **Export** or **File** ▶ **Save as**. From the **Save as type** list, choose **PDF - Adobe portable document format**, and click **Export** or **Save**. Fine-tune your output by choosing options in the **PDF settings** dialog box.

 To access the advanced PDF options from the **Publish to PDF** dialog box, click **Settings**.

To create a PDF preset, choose settings in the **PDF settings** dialog box, click the **General** tab, and click the **Add PDF preset** button next to the **PDF preset** list box. Type a name for the preset in the **Save PDF preset as** list box.

To export only selected objects in CorelDRAW, enable the **Selected only** check box in the **Export** dialog box or in the **Save as** dialog box.

Collect for Output wizard

CorelDRAW

If your print service provider needs to make any changes to your file, you can use the **Collect for output** feature to create a ZIP folder that can be sent to the print service provider. The folder contains the CorelDRAW file, a PDF version of the CorelDRAW file, and the fonts and color profiles that were used in creating the document.

Give it a try

- Click **File** ▶ **Collect for output**, and follow the instructions in the wizard.

ConceptShare

CorelDRAW and Corel PHOTO-PAINT

If you want to share your design with your client in a virtual workspace, you can use ConceptShare. This Web-based service lets you post your design and make it available exclusively to your client, who can then review the design and post comments.

Give it a try

- 1 Click **Window** ▶ **Dockers** ▶ **ConceptShare**.

The **ConceptShare** docker appears.

- 2 Do one of the following:
 - If you have a ConceptShare account, type your user name and password, and click **Submit** to sign in.
 - If you don't have a ConceptShare account, click **Sign up now**, create an account, and sign in.
- 3 After signing in, do one of the following:
 - In CorelDRAW, click **Publish page** in the **ConceptShare** docker.
 - In Corel PHOTO-PAINT, click **Publish image** in the **ConceptShare** docker.
- 4 Follow the instructions on the ConceptShare Web site to share your design with your clients.

Examples

The images in this section show page layouts that were created in CorelDRAW and Corel PHOTO-PAINT by using the features and techniques recommended in this chapter.

More examples of page layout design appear on the Gallery pages in Part Seven.



Image by Patrick Fraser

Till Maginot
 Wendelsteinstraße 24
 84508 Burgkirchen
 Tel.: on request
 E-Mail: till@maginot.eu
www.till.maginot.eu

Till Maginot
 Wendelsteinstraße 24
 84508 Burgkirchen
 Tel.: on request
 E-Mail: till@maginot.eu
www.till.maginot.eu

Michaela Maginot
 Bozaunweg 13 - 82008 Unterhaching
 Tel.: +49 (0)89 - 746 124 - 06
 Fax: +49 (0)89 - 746 124 - 06
 Mobil: +49 (0)173 - 298 385 2
 E-Mail: mm@m-maginot.de

Michaela Maginot
 Bozaunweg 13 - 82008 Unterhaching
 Tel.: +49 (0)89 - 746 124 - 06
 Fax: +49 (0)89 - 746 124 - 06
 Mobil: +49 (0)173 - 298 385 2
 E-Mail: mm@m-maginot.de

Michaela Maginot
 Bozaunweg 13 - 82008 Unterhaching
 Tel.: +49 (0)89 - 746 124 - 06
 Fax: +49 (0)89 - 746 124 - 06
 Mobil: +49 (0)173 - 298 385 2
 E-Mail: mm@m-maginot.de

Michaela Maginot
 Bozaunweg 13 - 82008 Unterhaching
 Tel.: +49 (0)89 - 746 124 - 06
 Fax: +49 (0)89 - 746 124 - 06
 Mobil: +49 (0)173 - 298 385 2
 E-Mail: mm@m-maginot.de

Michaela Maginot
 Bozaunweg 13 - 82008 Unterhaching
 Tel.: +49 (0)89 - 746 124 - 06
 Fax: +49 (0)89 - 746 124 - 06
 Mobil: +49 (0)173 - 298 385 2
 E-Mail: mm@m-maginot.de

Michaela Maginot
 Bozaunweg 13 - 82008 Unterhaching
 Tel.: +49 (0)89 - 746 124 - 06
 Fax: +49 (0)89 - 746 124 - 06
 Mobil: +49 (0)173 - 298 385 2
 E-Mail: mm@m-maginot.de

Image by Michaela Maginot

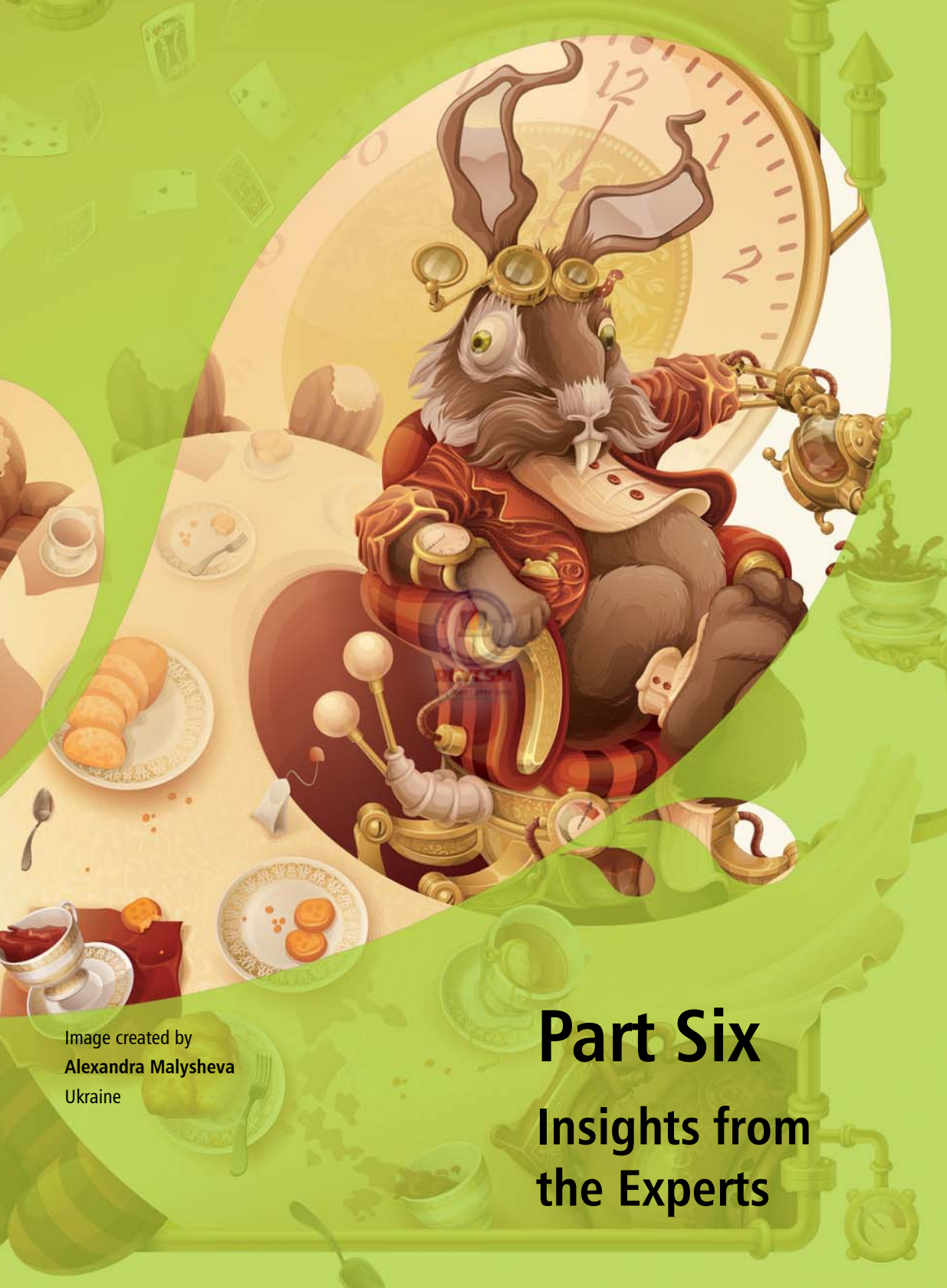

Image created by
Alexandra Malysheva
Ukraine

Part Six

Insights from the Experts



Chapter 16: Design of a Soccer Club Logo

Daniel Paiz



About the author

Daniel Paiz lives in Tuxtla Gutiérrez, Chiapas, Mexico. He graduated from the Gestalt School of Art and Design in Tuxtla. As a graphic designer with experience in multiple areas of design and print, he has worked for several advertising agencies in Mexico and the United States. In the past few years he has been working in the sports industry, designing logos and identities for soccer clubs. Currently, he works from his own online studio for several brands, creating graphic projects and demonstrating the power of CorelDRAW to create professional designs. Daniel has been using CorelDRAW as his principal design tool since 2000 and has shared his expertise as a Beta-tester of CorelDRAW Graphics Suite since version X4. Visit his Web site at www.danielpaiz.mx.

Chapter 16: Design of a Soccer Club Logo

The logo of a professional soccer team must be related to the local social, cultural, and economic scene. The imagery must inspire pride in loyal followers and communicate the essence of the team's vision and values to the general public. In this case, the Chiapas soccer club was looking for a new logo that could better convey the team's spirit, identity, and values (Figure 1).

Before I start working on the concept of the new logo, I analyze the old logo in order to understand the reasons why it was not successful. I notice that there is no relationship between the imagery and the team's history, identity, or environment. The image reflects the soccer club's name, but the jaguar's head is turned to the left, which can be interpreted to mean retreat or escape from rivals.



Figure 1: New logo (left) and old logo (right)

Establishing the client's needs

Before I begin, I must establish the general requirements and goals of the project and formulate a strategy to achieve them.

1. The logo does not have a regional identity.

- Solution: Highlight local features.
- Result: Fans will support the team as an expression of their culture and identity.

2. The imagery does not have the right graphic style.

- Solution: Improve the style of the vector trace. It needs to be clean, well-defined, and easy to recognize.
- Result: Improving the trace will have a direct impact on the aesthetics of the

design and will create more possibilities for production.

3. The current concept does not adequately convey the team's spirit and values.

- Solution: Create a well-defined concept that includes better management of graphic elements.
- Result: The image will project the right message and will be easier to understand.

Having a sound concept and a solid technical implementation can prevent many problems, from lack of visual appeal to difficulties in production when using the logo across different media and applications (Figure 2).

The tools in CorelDRAW allow me to cover all of these areas by optimizing my files from the beginning.



Figure 2: Examples of different applications and printed media

Researching the logo elements

When you work for a soccer club, you meet people who have dedicated their lives to the success of the team. They share common values and work passionately towards a common goal — to ensure that the club runs smoothly and to promote the team to the highest level of professional soccer.

There are a few guidelines to keep in mind when you design a sports logo:

- Talk to the players and the people in the club. Listen to their suggestions and ideas, get to know their needs and expectations.
- Get to know the competition. Research of the logos of other national teams gave me a broader idea of the soccer market and the strategies that each team uses to strengthen its graphic message. Do not copy or use elements of other logos. In this business, people always keep an eye on the competition.
- Do not design from memory. For example, whenever you want to draw an animal, observe the real animal. In this case, visiting the zoo helped me study the jaguar to find the right angle for the animal in the logo. The soccer ball is another example. I used a real soccer ball as a reference. I tore apart a couple of soccer balls and studied the way the pieces were attached to each other.

First, I have to identify the right elements to include in the logo — elements that will resonate with the team and the fans — and then I must document every element that I am planning to use and the rationale behind it.

Soccer — The soccer ball, and more specifically the Telstar model that was used in Mexico in the 1970 World Cup, has become a world-wide symbol of soccer. I want to use a

partial image of the soccer ball and integrate it into the jaguar head, so I make 3D renderings of the ball to find the right angle (Figure 3). Had I simply used a full soccer ball, I would have ended up with the single most common element across all soccer logos.



Figure 3: Creating a 3D rendering of the soccer ball

Jaguar — The image of the jaguar is deeply ingrained in local culture and tradition. The animal, revered for its power and courage, is considered one of the iconic animals in the Chiapas state. The jaguar is the basic element in the design, as its shape, color, and expression define the logo (Figure 4).

Geometric shapes from Mayan

architecture — The Mayan culture is native to this region of the country and has a huge influence across the entire Chiapas state. The Mayans are recognized and admired for their architectural achievements (Figure 5). I decide to merge the geometric shapes used by our ancestors with the spots of the jaguar to represent both elements in an abstract manner. The beauty and color of the rainforests are also represented by the mystic green in the final logo.

Coat of arms — In our culture, soccer players are considered the new warriors and are a source of pride for the fans. Currently, eleven soccer teams in Mexico use a coat of arms in their logo. The coat of arms is a symbol of the commitment to protect the honor of and represent the Chiapas state, as well as an important symbol of soccer culture throughout the world (Figure 6).

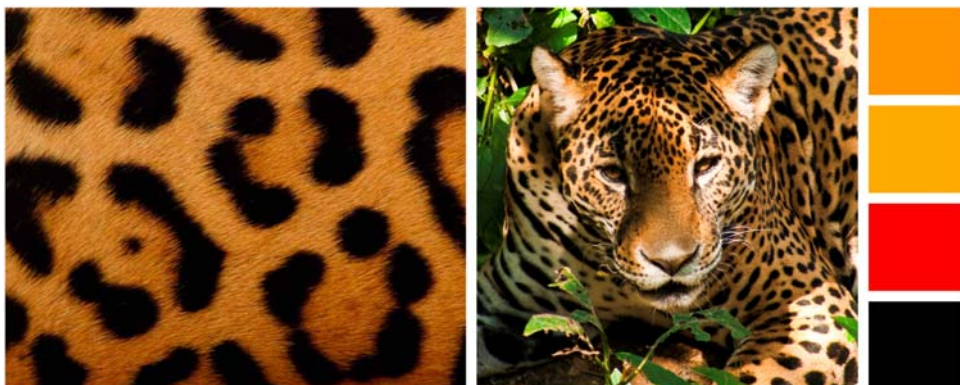

Figure 4: Studying the shape, color, and expression of the jaguar (photo by Arturo Arias López)



Figure 5: Elements of Mayan architecture help ground the logo in the history of the region (photo by Arturo Arias López).

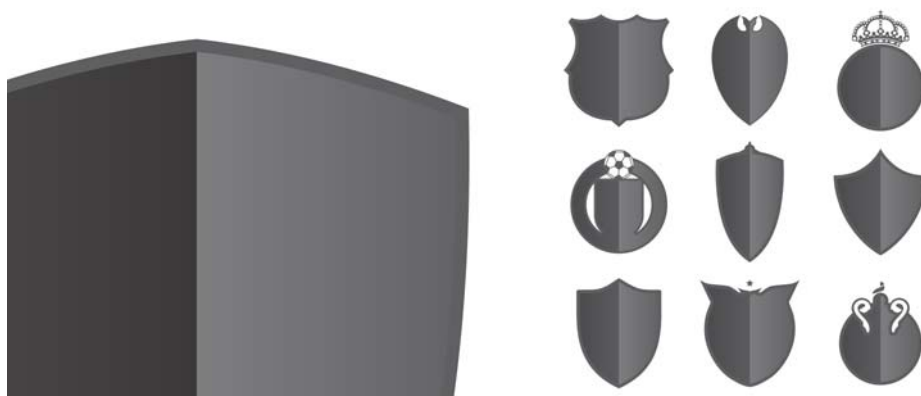

Figure 6: The coat of arms is an important part of soccer culture across the world.



Figure 7: Sketching process to define the jaguar head

Time to design

The first step is to create a sketch. In this case, I start with the jaguar. At this stage, it's a good idea to use a blue pencil (Figure 7), so that when I have a well-defined image, I can use black ink to identify the master trace (Figure 8). As the design evolves, I make decisions on the fly with regards to the sketch.

My plan is to partially integrate the soccer ball into the head of the jaguar, so that the jaguar's fur spots take the shape of the hexagons of the traditional soccer ball (Figure 9). The decision to replace the natural spots of the jaguar with the soccer ball may sound like a crazy idea, but after I found the right angle, it suited the

composition perfectly. I also remove the whiskers because they make the head take up too much space. In this way, the logo becomes more compact.



Figure 8: The complete sketch

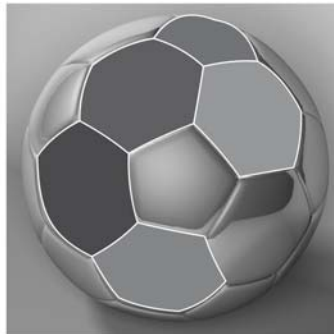

Figure 9: The soccer ball is partially integrated into the jaguar head.

Image digitalization

The first step of the design process is complete. It's worth mentioning that at this stage there isn't a single straight line in the image, which makes digitalization very challenging. Using geometric shapes, I can find the most perfect possible trace, which involves finding the center of each curve used in the sketch. This can take a while depending on the skill of the designer. I use two tools: the **Ellipse** tool and the **Smart fill** tool.

The **Smart fill** tool allows you to create objects from the intersection of two lines (Figure 10). It doesn't matter how complex the lines are; this tool is very useful for creating shapes from the filled areas. As a visual guide, I can use different outline colors for each object that

I am digitalizing, so that I have better control. I start by creating intersecting circles using the **Ellipse** tool. Whenever I have a fully defined segment, I fill it using the **Smart fill** tool, and then I combine all segments into a single curve object (Figure 11 and Figure 12). This process is not difficult but it requires some patience.

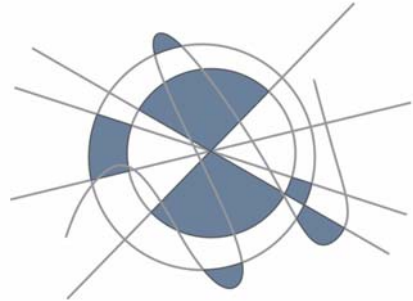

Figure 10: The blue objects are created from the space between the intersecting lines.



Figure 11: Geometric details from the digitalized sketch. The **Ellipse** tool is used to create intersecting circles, and the **Smart fill** tool is used to fill the overlapping areas and convert them to objects.

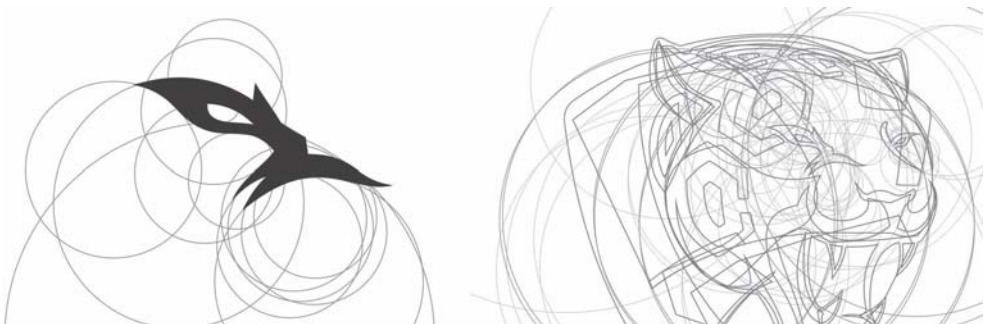

Figure 12: The jaguar head is gradually defined.



Figure 13: Hand-drawn sketch and digital drawing

The digitalized drawing has some minor differences from the hand-drawn sketch, but the traces look better defined — clearly outlined eyes, rounded ears, longer teeth and tongue, thicker outlines (Figure 13).

Using the jaguar's natural spots as a guide, I identify a pattern with six sides, which can be naturally incorporated into the hexagons of the soccer ball (Figure 14). Using the **Contour** tool (**Ctrl + F9**), I add two inside contours to each hexagon. First, I create a one-step contour (cyan) and separate the objects of the contour group (**Ctrl + K**). Then, I select the cyan object and apply the second one-step contour (magenta). Next, I separate the objects of the second contour group. I delete the middle step by selecting the original hexagon and the cyan object and clicking the **Back minus front** button on the property bar. I remove the colors, and I have the final result.

When I start incorporating the hexagons into the head, I run into a problem: the hexagons

overlap with the eyes and mouth of the jaguar (Figure 15). However, I don't need to use all hexagons to achieve the soccer ball effect, because the 3D rendering produces a sphere effect on the jaguar's head, suggestive of a soccer ball. I delete a couple of hexagons and I am left with the three main jaguar spots.

I erase some parts of the hexagon objects to give them a more authentic look, similar to the jaguar's natural spots, as well as to achieve harmony with the other elements, such as the jaguar's eyes and ears.

Another technique that can help with the visual recognition of the shapes is to increase the spacing between the hexagons. Other adjustments include rounding of all corners and traces.

The next step is adding the team name to the logo (Figure 16). Finally, I add color and some shadows to make the image look less flat (Figure 17).

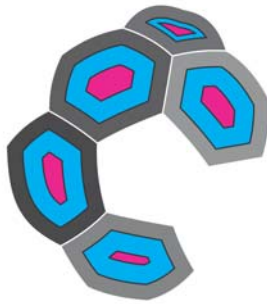

Figure 14: Creating hexagons based on the jaguar spots

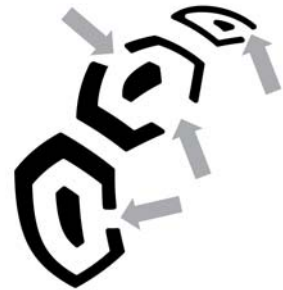

Figure 15: Modifying and positioning the hexagons



Figure 16: Adding the team name



Figure 17: Adding color and shadows

Final steps

The final steps in the logo design process include creating color variations, producing grayscale and monochromatic versions of the artwork, establishing minimum and maximum reproduction size to avoid distortions, and defining the safe area around the logo that is necessary to keep the image apart from other elements in visual materials (Figure 18).

Topics for the logo style guide

The style guide is a document that defines the requirements of the logo usage, so that anyone can use the design and understand the basic principles of its reproduction. The guidelines ensure accurate and consistent representation of the logo and guarantee that the logo delivers a strong and positive message.

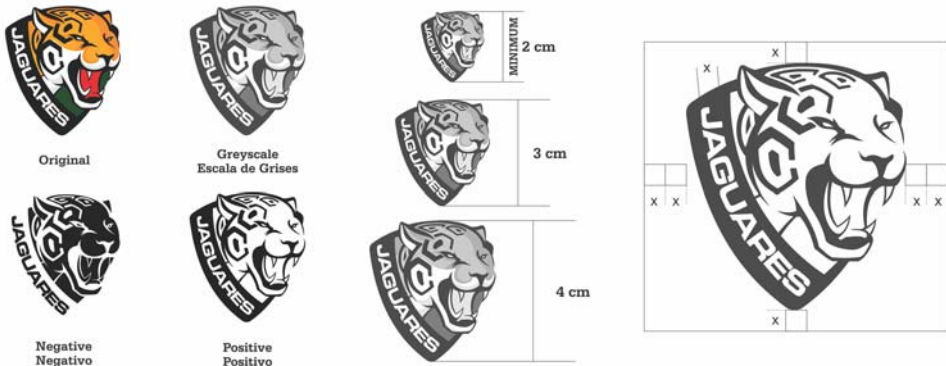

Figure 18: Variations in color and scale

Even though the purpose of this document is to provide instructions to the people responsible for the reproduction and distribution of the logo, it's important that anybody — even people without any background in design — can understand it. For this reason, clarity is essential.

Some basic topics that I cover in the guide include background and purpose, size and color chart, typography, and guidelines for the use of corporate identity. With this information, I can ensure that all logo reproductions communicate the values that the brand represents.

Designing the style guide

Grids and margins are important elements in document design. A grid is a non-printable guide that helps the designer lay out text and images by dividing the text into columns to make it easier to read.

Personally, I use CorelDRAW like a blank canvas; I don't like to limit my workspace, so I typically disable the page border (click **Layout ► Page setup**, and disable the **Show page border** check box). In this case, however, a page border gives me better control over the text columns.

A square page layout represents some extra challenges, as it is not a conventional format. I decide to divide the page into three sections to create a visually balanced and well-defined composition (Figure 19). The top, left, and right margins are 1 cm, and the bottom one is 1.618 cm. These proportions are also known as the "golden ratio." Many artists use the golden

ratio in their artwork to produce aesthetically pleasing compositions.

The three-column layout simply provides the basic design framework; it does not limit my ability to position objects as I like. A quick way to create columns with equal dimensions is to make a paragraph text frame (by dragging with the **Text** tool) and then divide it into columns of equal width. To calculate the dimensions of the text frame, I subtract the margins from the page size. With the current margins, for example, if the document is 25.4 x 25.4 cm, the text frame should be 23.4 x 22.7 cm, so I type these values in the **Object size** boxes on the property bar.

After I create the text frame, I open the **Layout** toolbar (**Layout ► Layout toolbar**) and click the **Columns** button. In the **Column settings** dialog box, I increase the number of columns to three, with a gutter of 0.5 cm. The spacing between the columns is adjusted automatically so that they are evenly spaced across the frame. Alternatively, you can calculate the width of each column yourself. CorelDRAW offers you the flexibility to accomplish the same task by using different features depending on your workflow.

Next, I press **Ctrl + K** (or click **Arrange ► Break paragraph text apart**) to split the columns and work with them independently while keeping the layout flexible. When I break the columns apart, they become three separate paragraph text objects, which are no longer connected. This is an easy way to get several paragraph frames that are evenly spaced on the page. Since the style guide will contain text in two different languages, I don't want the columns to be linked.

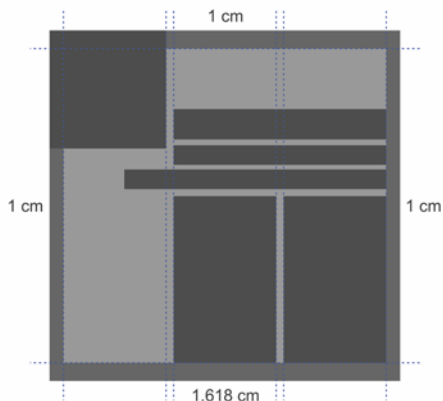

Figure 19: The page is divided into three columns, which can simply serve as guidelines without limiting the possibilities for layout of the content.

When I design a multipage document containing text, I try to optimize my workflow. For example, creating text styles provides a quick way to ensure consistent formatting across multiple pages without imposing limits on the content or composition (Figure 20). A style can include more than one text property, such as color and font size. For example, if I

want all titles to use a large font size, I don't have to format them all one by one. Instead, I format one title, open the **Object styles** docker (**Tools ▶ Object styles** or **Ctrl + F5**), and drag and drop the formatted title in the **Style sets** folder to automatically create a text style based on this formatting. After this, I can apply the style to any text by selecting the text and double-clicking the style set in the docker.

Placeholder text (right-click a blank column, and click **Insert placeholder text**) can help a lot with the design and layout of text and graphics. The traditional "Lorem ipsum" placeholder text has a structure that is similar not only to English writing, but to many other languages as well, so it can give me a good reference point for the visual flow of body text. It's also very useful when a client must review only the graphics in a project. The placeholder text helps the client focus on the graphics, saving him the time and effort of providing unnecessary feedback on text that may still be work in progress.

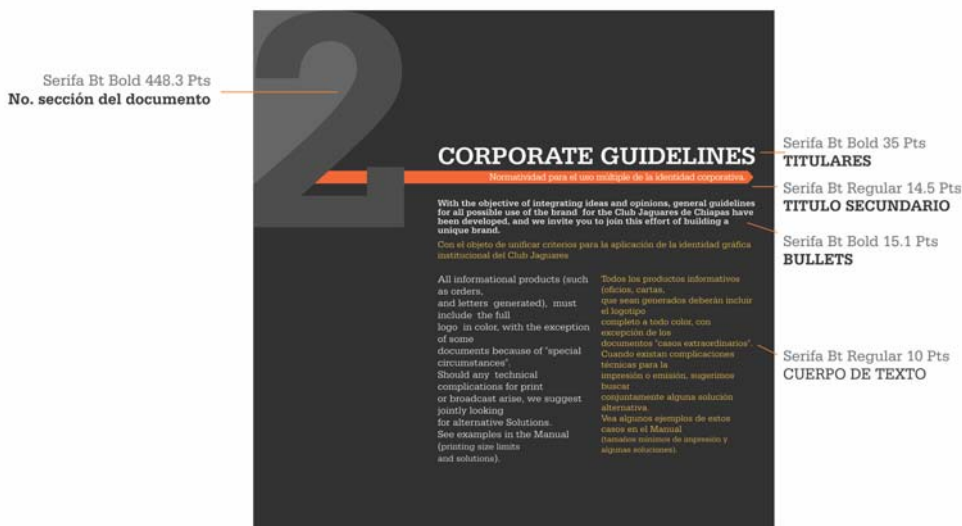

Figure 20: Using styles to format the text



Figure 21: Empty space helps create a better composition.

Don't be afraid of white space. The so-called negative space isn't really so negative. It helps to create a balanced and harmonious

composition (Figure 21). Remember the rule of thirds: 1/3 text, 1/3 image, 1/3 white space.

Use less content on each page for greater visual impact. This project is a bilingual style guide, so all information is repeated in two languages, but if I had used a single language, I could have easily kept the same layout, with only half the text per page. To compensate for the unequal column length, I use a slightly smaller font for one of the languages (Figure 22).

Keep in mind that the image on screen may look different when printed, and you can avoid unpleasant surprises by soft proofing (click the **Proof colors** button on the status bar). It's important to turn on color proofing every now and then to see a preview of the printed document (Figure 23 and Figure 24). For more information, see "Soft proofing" on page 98.

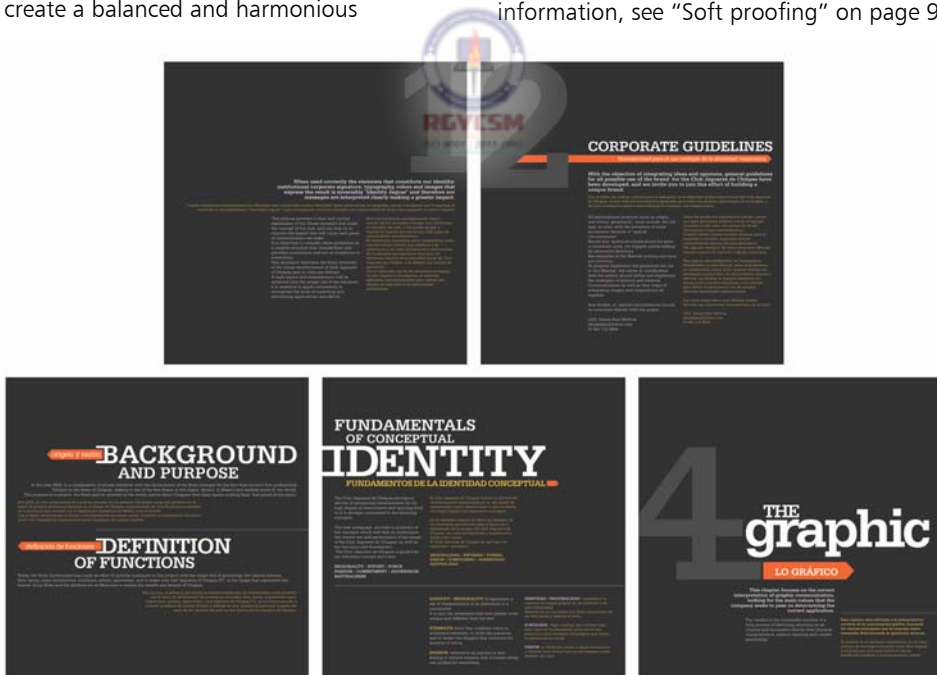

Figure 22: A few pages of the logo style guide

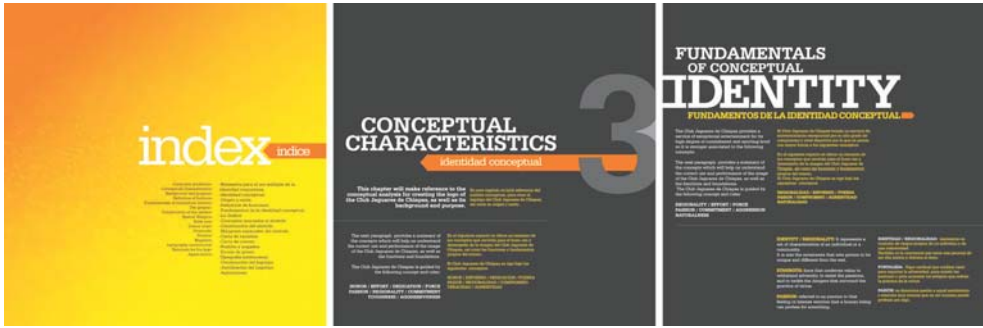

Figure 23: The document as it appears on screen (color proofing off)



Figure 24: A preview of the document in print (color proofing on)

When you are ready to send the project to the client or printer, I recommend publishing it as a PDF to prevent accidental changes to the content prior to printing. Generally speaking, the client is likely to request additional changes, so unless the client asks for it, you don't need to submit the original .cdr file.

In conclusion, if you have an idea, no matter how complex, CorelDRAW provides the tools you need to make it happen, with the most professional results and high-quality imagery in both printed and digital media.

Chapter 17: The Story of a Reader Chair

Michal Polák



About the author

Michal Polák lives in the Czech Republic, in the town of Újezd u Brna, South Moravia. He graduated in 2001 from the advertising and graphics program of the College of Applied Arts and Graphics in Jihlava. In 2009, he completed a design program at the Academy of Arts, Architecture and Design in Prague. He now works at Francisdrake, his own graphics studio, with his colleague Zdenek Pudil. For many years, Michal has worked with CorelDRAW as a primary tool for creating all types of designs, including stationery, catalogs, logotypes, corporate identity materials, business cards, posters, Web designs, and technical drawings. The chair design featured in this article received an award at the Mobitex 2006 international trade fair. Visit Michal's Web site at www.francis-drake.eu.

Chapter 17: The Story of a Reader Chair

A café is a place where you go for good coffee, chocolate, and desserts; a place where you meet friends, relax, and read books; a place where you spend your free time. Cafés are filled with readers of classic books and modern notebook users. What do people carry with them into the café? Jackets, scarves, hats, books, magazines, newspapers, and so on. The question is, where to put all these items? The tables in coffee shops are usually very small and

often covered with advertising leaflets. There is place only for a cup of coffee or dessert, not for big books and magazines. The main idea for this project was to design an original chair for a café. The challenge was to create a chair that was comfortable, compact, and equipped with convenient and versatile storage space, which could be used for books, magazines, or coats. By creating a pocket on the backrest of the chair, I solved the problem (Figure 1).



Figure 1: Final design

Tracing the basic shape

After I scanned and imported the sketch into CorelDRAW, I used the **Bézier** tool to trace the basic shape of the chair as seen from the side (Figure 4).

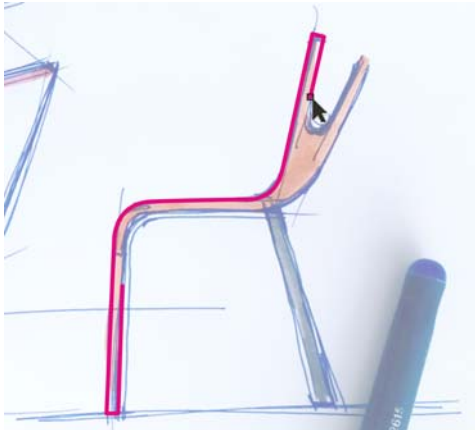

Figure 4: Outlining the main shape

While drawing with the **Bézier** tool, I could switch to Quick Pan mode by holding down the middle mouse button and dragging. The pan mode for drawing tools allows smooth panning without having to scroll down the page or change tools. I created one continuous curve for the top part of the chair (Figure 5).



Figure 5: Outline of the top of the chair

For the back chair leg, I created a rectangle with the **Rectangle** tool (Figure 6) and then skewed the rectangle (Figure 7) by using the **Transformations** dock (Window ► Dockers ► Transformations ► Skew). Now the basic outline was complete.



Figure 6: Drawing a rectangle for the leg



Figure 7: Skewing the rectangle

Ergonomics

When designing furniture, I always use a digital human model to ensure that the final product follows basic ergonomic principles. I

use the same figure in different sizes, depending on the project. For example, projects such as designing car seats for children or chairs for people of different ages require human models of various sizes.

In this case, I used a ready-made human figure with a height of 175 cm set in a proper sitting position (Figure 8). The virtual model came from a 3D program, Rhinoceros 3D, which is easy to use with CorelDRAW.

Digital human models are an essential tool in industrial design. Designers should always use digital models to check the proportions of their products. If you design chairs, car seats, beds, bathtubs, cars, homes, and so on, you have to use human figures to guarantee compliance with safety and ergonomic standards. To make sure that the chair was ergonomic and comfortable for sitting, I had to use either a digital model, or a real human sitting on a prototype of the chair.

After importing the seated figure into CorelDRAW, I used the **Freehand** tool to create curves around it and outline the basic surfaces of a chair (Figure 9). Holding down **Shift** while drawing with the **Freehand** tool creates a straight line. For the backrest, I drew a curve along the back of the figure, and then scaled the curve to make it longer (Figure 10).

Then, I drew a horizontal line to mark the height of the backrest (Figure 11). I estimated that this height would be comfortable for a chair of this design, taking into account the figure's center of gravity.

Based on the digital model, I had found the right proportions for a chair that supports proper sitting posture.

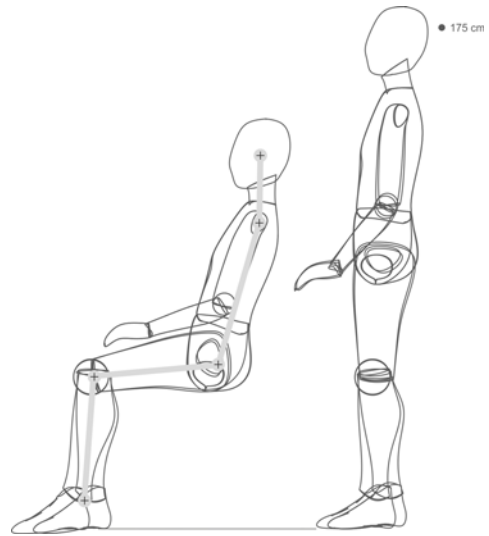

Figure 8: A human figure is imported into CorelDRAW.

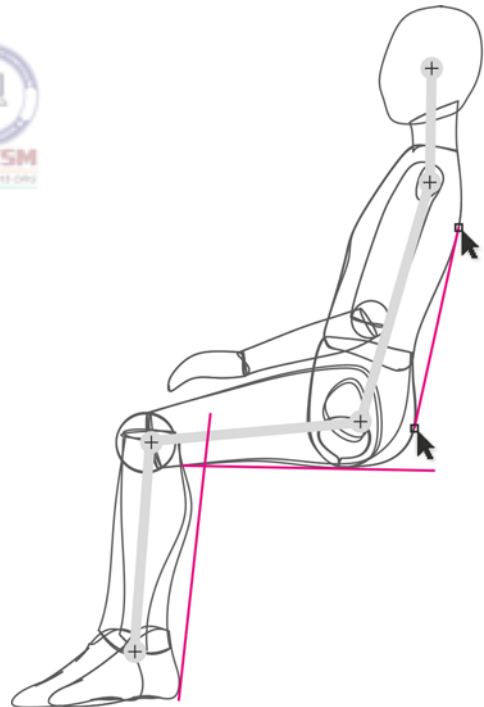

Figure 9: Drawing a chair outline around the figure

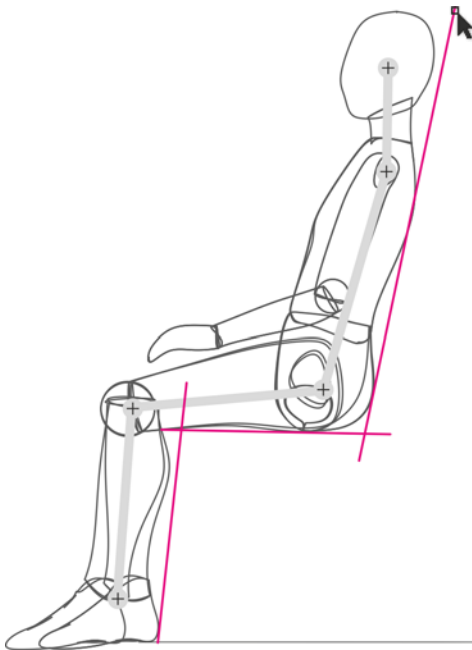

Figure 10: Extending the curve for the backrest

When the outline was complete, I separated it from the human figure (Figure 12). I now had a basic outline representing a chair constructed according to ergonomic principles.

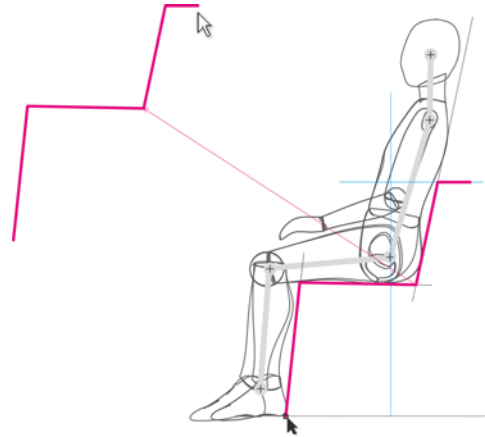

Figure 12: Separating the outline

I put the original traced shape on one layer, and then I placed the ergonomic outline on another layer on top of it (Figure 13).

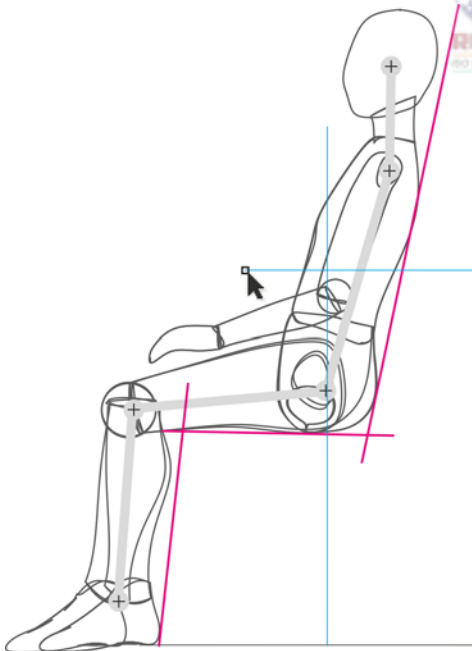

Figure 11: Drawing a horizontal line to mark the height of the backrest

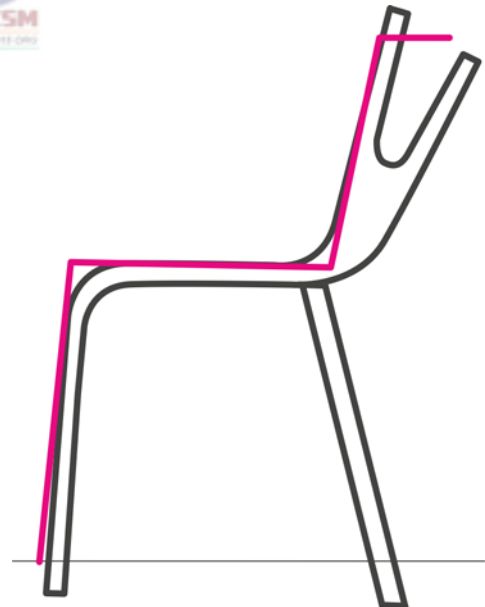

Figure 13: The ergonomic outline is superimposed on top of the original traced shape.

I drew a new outline with the **Bézier** tool, using as guidelines the ergonomic outline and the original traced sketch. The resulting shape represented a chair outline adapted to ergonomic principles. Then I duplicated every line and placed the copy at a distance from the original to account for the thickness of the material (plywood). I measured the real thickness of the plywood and applied the same proportions in the drawing (Figure 14).

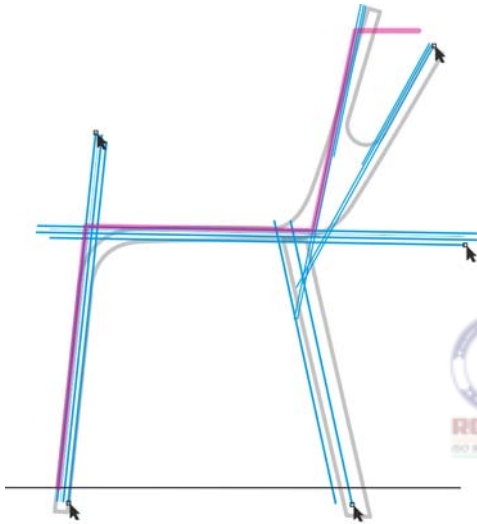

Figure 14: The blue lines are duplicated and spaced out according to the thickness of the material.

Next, I created circles of different sizes and snapped them to the intersections where I wanted to create rounded corners (Figure 15). I shortened the straight lines to the points where they intersected with the circles (Figure 16).

To create rounded corners, I broke up the circles into arcs by clicking the **Arc** button on the property bar, and then I moved the end points of each arc so that the arc was 1/4 of the circle (Figure 17).

You can move the nodes of the arc manually with the **Shape** tool or type values in the **Starting and ending angles** boxes on the property bar for greater precision.

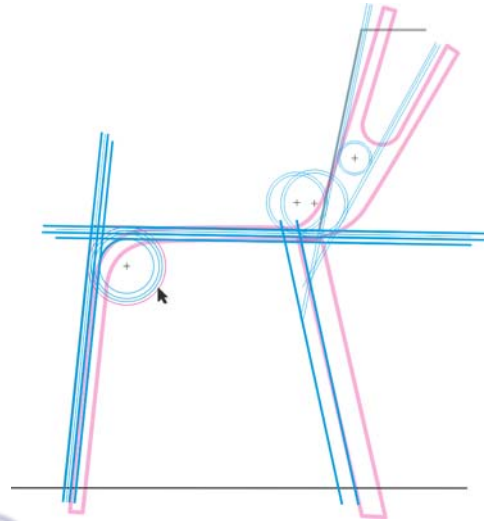

Figure 15: Circles are added at intersections of straight lines.

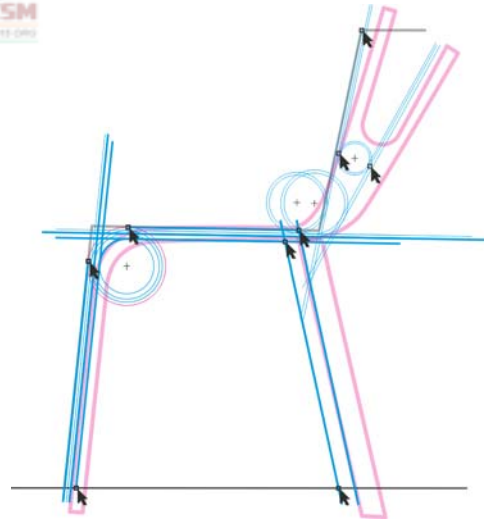

Figure 16: The straight lines are shortened so that they end at the intersections with the circles.

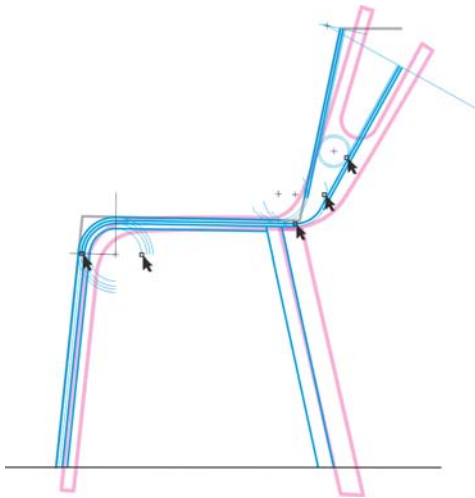

Figure 17: Turning the circles into arcs to create rounded corners

The outline was now complete. The design captured the original idea from the traced sketch, while also incorporating basic ergonomic principles (Figure 18).

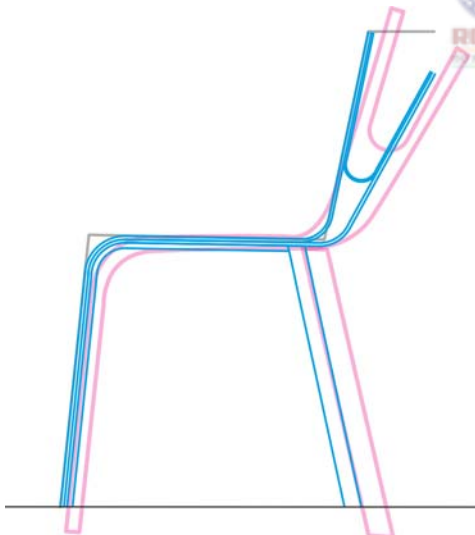

Figure 18: The final outline (blue) is based on the original traced sketch (purple) and the ergonomic outline (black).

Finally, I closed all open lines of the object (Figure 19). I used the **Shape** tool to select each two end nodes that I wanted to join, and then clicked the **Join two nodes** button on the property bar.

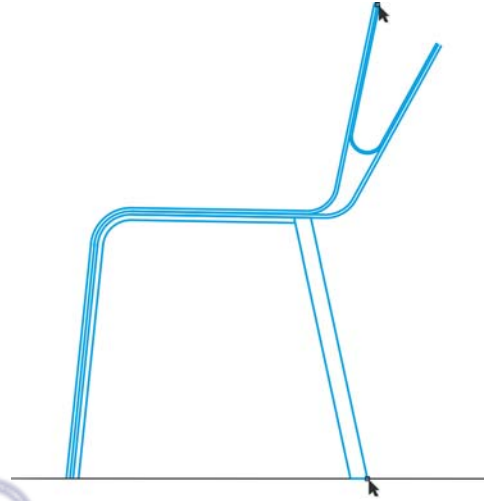

Figure 19: All open curves are closed.

When the side view of the chair was ready, I created the back view based on it (Figure 20).

Finally, I verified the design by adding the seated human figure to the chair (Figure 21).

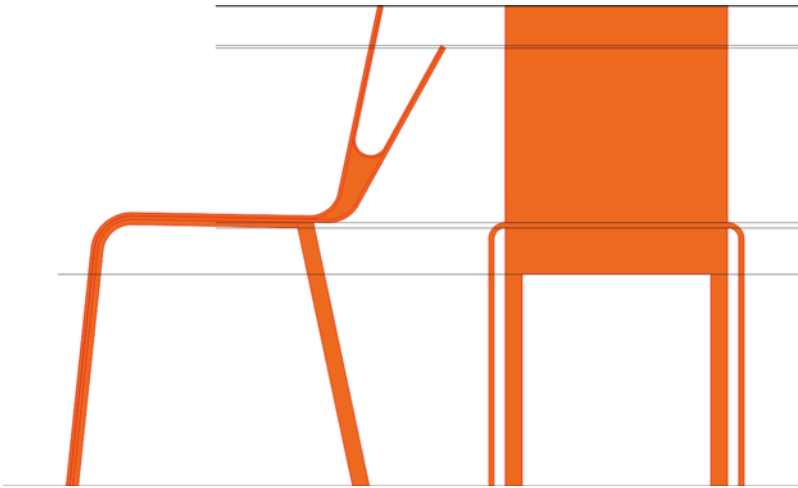

Figure 20: Side and back view of the chair

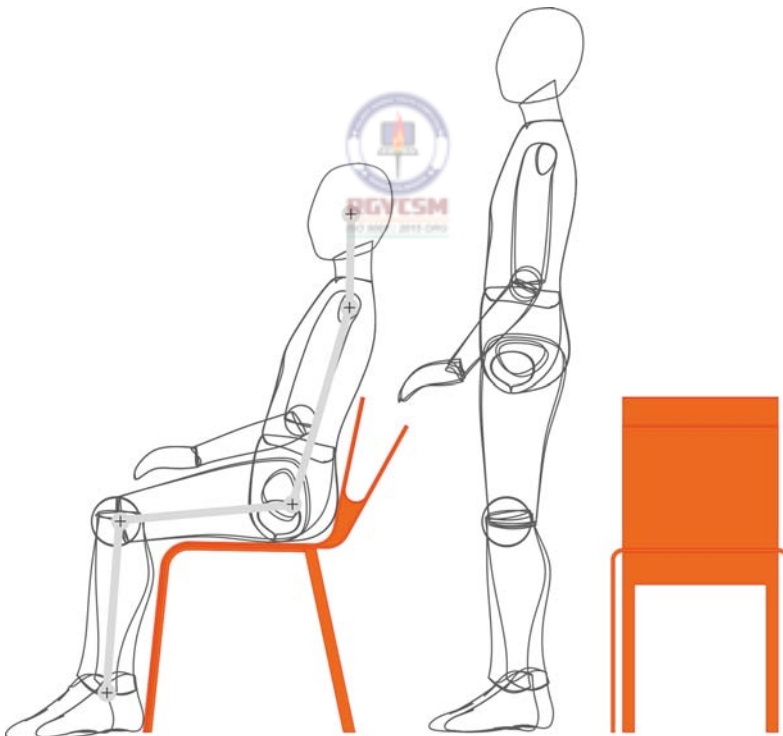

Figure 21: Verifying the final design

Adding colors

With the rich color-mixing capabilities of CorelDRAW, I could fine-tune the color of the chair as needed.

CorelDRAW provides a fast and easy way to mix colors. First, I chose a color swatch from my printed RAL color chart, and then I recreated the color in CorelDRAW on my calibrated Eizo monitor. I usually use the CMYK and PANTONE color palettes.

When my color palette was ready, I simply dragged a color swatch to the object to apply the color (Figure 22). I used the **Interactive fill** tool to create transition effects from darker to lighter shades of the same color.

I chose different colors that would make the chair look good (Figure 23).

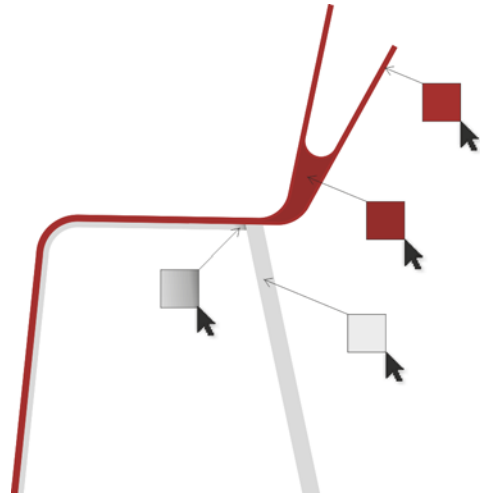

Figure 22: Applying color to the chair

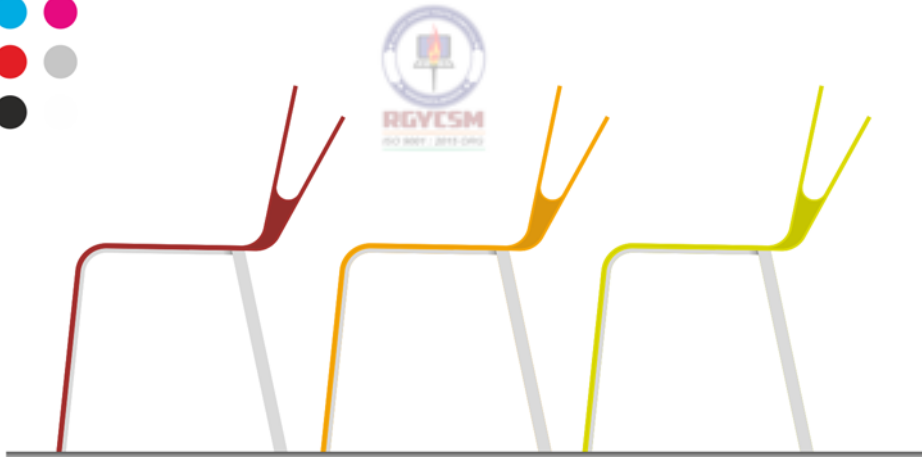

Figure 23: The chair in different colors

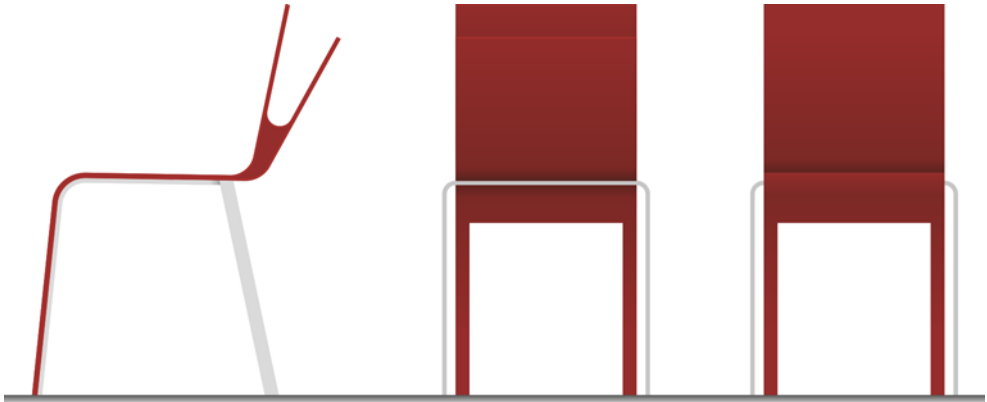

Figure 24: Side, back, and front view of the chair

Creating a 3D visualization

The chair was done in 2D views (Figure 24). Now was the time to convert it to 3D. I exported the basic outline of the chair as a DWG file, which I opened in the Autodesk® 3ds Max® Design software. The resulting visualization showed what the chair would look like in real space (Figure 25).



Figure 25: 3D view of the chair



Figure 26: Mirroring the rectangle and importing the chair

Creating a presentation booklet

When the 3D visualization was done, I opened CorelDRAW again to create a presentation booklet for the chair.

I wanted to create a single-fold 4-page brochure. First, I created the inside pages. I drew a rectangle and mirrored it to create a two-page spread (Figure 26). Then I imported the image of the chair and placed it in the middle of the two pages by snapping the center of the chair to the center of the page spread. The ability to snap objects to other objects, edges, or the center of the page is one of the great advantages of CorelDRAW. Thanks to this feature, I save a lot of time and I am 100% sure that the result will be accurate.

Next, I added text by using the **Text** tool and aligned it on the page by using alignment guides (Figure 27). The two inside pages of the booklet were done.



Figure 27: Adding text

On the back cover of the booklet, I wanted to create a visual presentation of the available colors for the chair. For each color, I created a small circle with a uniform fill, duplicated the circle (with the duplicate right on top of the

original), and then created a larger circle overlapping half of the duplicate circle (Figure 28). Then I selected the duplicate circle and the large circle, and clicked the **Intersect** button on the property bar to create an object from the intersection of the two objects. I discarded the two objects, leaving only the object created from their intersection. Then I filled this object with white and applied transparency to it, so that the underlying original small circle was partially visible. The transparency created a smooth transition between the light and dark shades of the color, producing a glow effect.

When I was done with the first circle, I dragged it to the right and pressed the right mouse button to duplicate it. I created multiple copies in different colors and spaced them evenly on the page, so that the distance between the circles was equal to their radius.

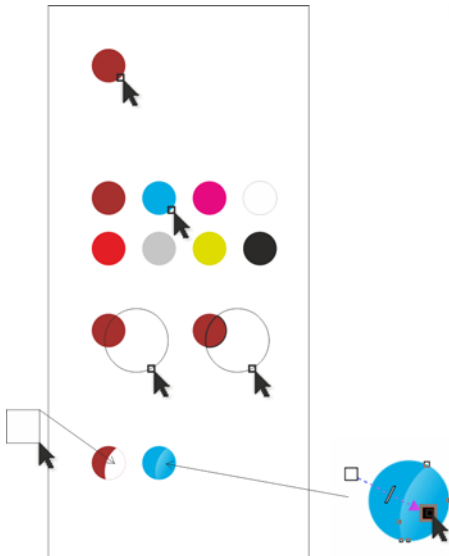

Figure 28: Creating color circles

On the back cover of the booklet, I placed the color samples and added text, and on the front

cover I placed the image of the chair, which I cut and aligned with the page (Figure 29).

To crop the image of the chair to the page, I used a long and narrow rectangle. I selected both objects and clicked **Arrange ▸ Shaping ▸ Back minus front** (the chair being the back object and the rectangle the front).

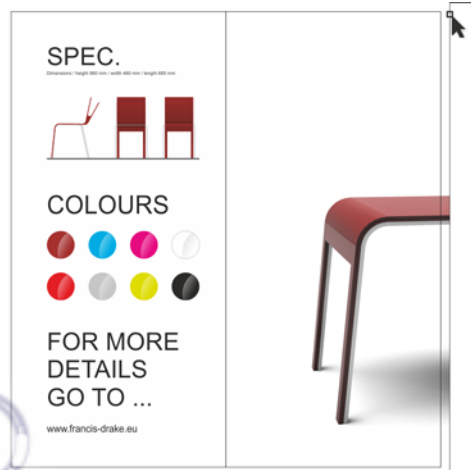

Figure 29: Trimming the end of the chair with a rectangle

All the objects were now aligned on the page in a harmonious and visually pleasing composition.

Next, I cut the image to the size needed for printing. Offset printers require adding a margin (also known as bleed) to allow for trimming the paper after printing. The final trim size of the brochure was 210 x 198 mm, so I added a 3.175 mm bleed on each side. This is a standard bleed size for offset printers. Finally, I exported the booklet to the PDF format with printer's marks, which CorelDRAW added automatically.

After that, the booklet was done and ready for print and production (Figure 30 and Figure 31).



Figure 30: The finished booklet design

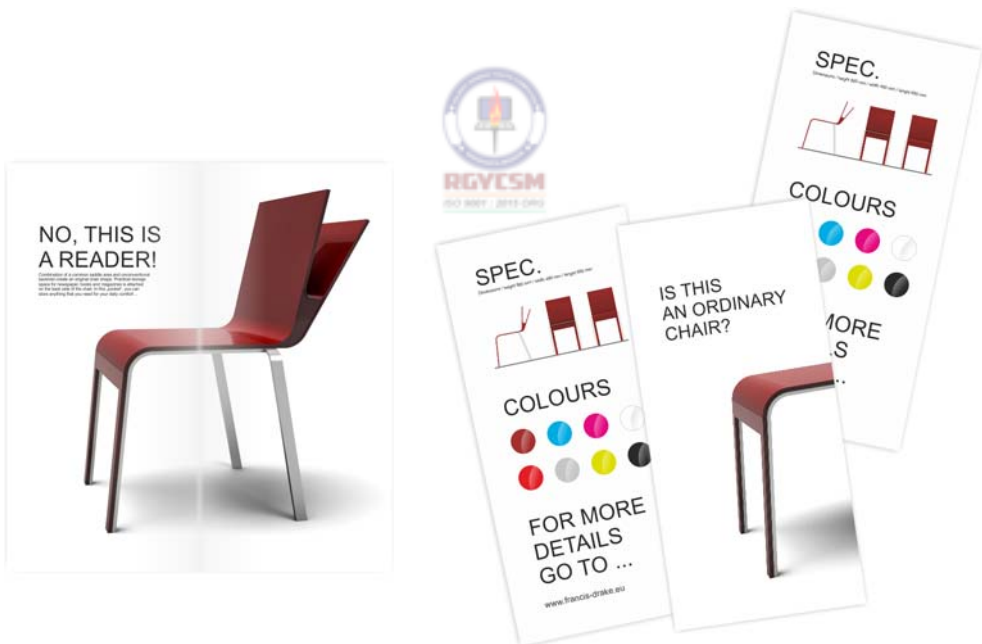

Figure 31: Final printed booklet

Production drawings

The final task was to create production drawings for the chair manufacturer (Figure 32 and Figure 33). Using the **Dimension** tools in

CorelDRAW, I simply dimensioned all chair parts. When the production drawings were complete, I printed them and handed them over to the manufacturer, who made the chair (Figure 34).

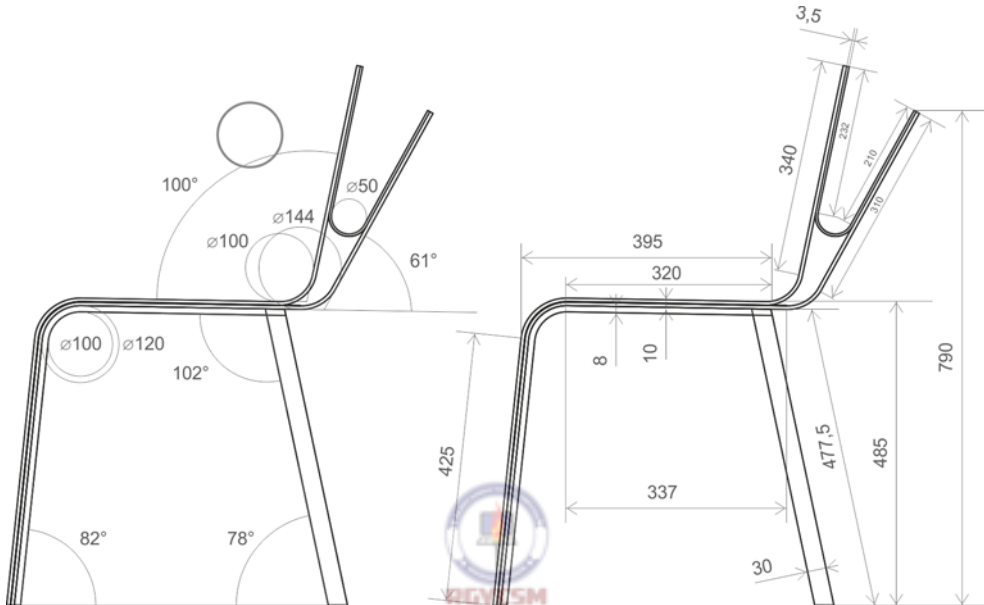

Figure 32: Production drawings (side view)

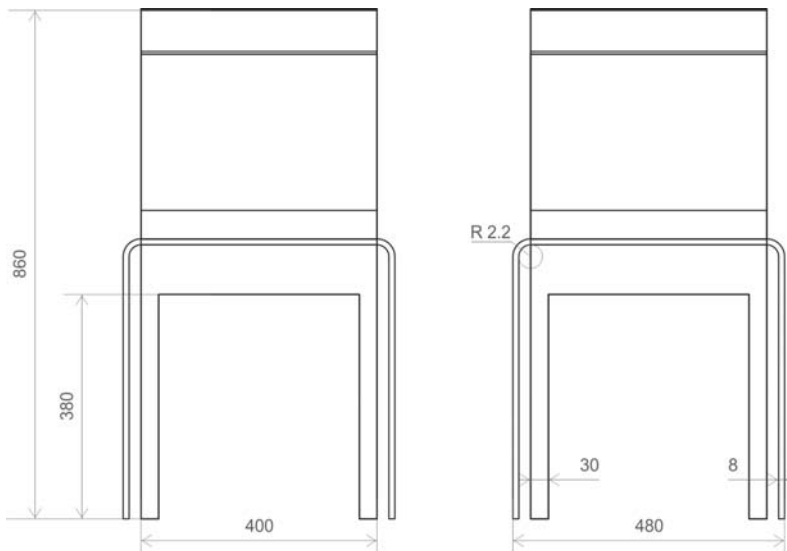

Figure 33: Production drawings (rear view)



Figure 34: Manufactured product

I use CorelDRAW as the main application for creating graphic materials. It's the perfect tool for developing the concept and basic shapes of the product design, which I subsequently export as curves to a 3D software to render photorealistic visualizations of the product. CorelDRAW also provides an easy way to make production drawings, which I send directly to the manufacturer.

CorelDRAW is a unique software that allows me to transfer my ideas from paper to reality. I use this tool for all my projects, including the creation of visual identities, Web sites, logos, catalogs, and product designs.

Chapter 18: Concept Art

Maurice Beumers (Mo)



About the author

Born and based in Germany, Maurice Beumers (Mo) learned to draw as a young child. An autodidactic study of numerous scientific subjects, including anatomy and optics, helped him develop his knowledge of shape, perspective, and figurative representation — all of which contribute to good illustration. After an apprenticeship in advertising, Mo began doing airbrush artwork on commission. He is now a corporate publisher for a European IT supplies enterprise as well as a passionate artist and illustrator. Mo has used CorelDRAW since version 6 and now takes full advantage of CorelDRAW Graphics Suite in his work with marketing materials and digital illustrations.

Chapter 18: Concept Art



Figure 1: Concept painting

Quiet and desolate, the houses lay in the shadow of the massive town gate. Single spots of golden light lent a gleaming fur to the ruins of timbered houses, decorated by vegetation which fetched back piece by piece the once so picturesque scenery. A lonesome traveler wrapped in a dark cape rose from his horse and looked around. But the forsaken and idyllic mood was only skin deep. Something oppressive and lurking lay in the shadows...

This scene could be taken from the plot of a fantasy role-playing game. My job as the concept illustrator is to provide a visual image that gives shape to this description (Figure 1).

On the following pages, I cover the basic workflow for creating concept art, and I provide details on the advantages of using

Corel PHOTO-PAINT. The easy-to-understand tools, customizable workspace, and limitless creative possibilities make this graphic application a powerful tool for digital artists and illustrators.

Sketching the first ideas

After establishing the picture in my mind, I use Corel PHOTO-PAINT to make some rough sketches. These sketches will later serve as a basis for elaboration of the image.

To produce each rough sketch, I click **File ▶ New** and choose my settings in the **Create a new image** dialog box. I specify a ratio of 1000 to 500 pixels and choose a light gray background. Next, I add a new object by clicking **Object ▶ Create ▶ New object**.

I can draw my sketch on this object as I would on an acetate sheet.

I use the **Paint** tool for sketching, usually with one of the preset brush types in the **Pencil** category.

I make the sketches very quickly and save them as CPT files. My intention is to capture an interesting viewpoint and expression of the entire scene (Figure 2). It is not important if the sketches are a bit clumsy and rough.



Figure 2: Rough sketches

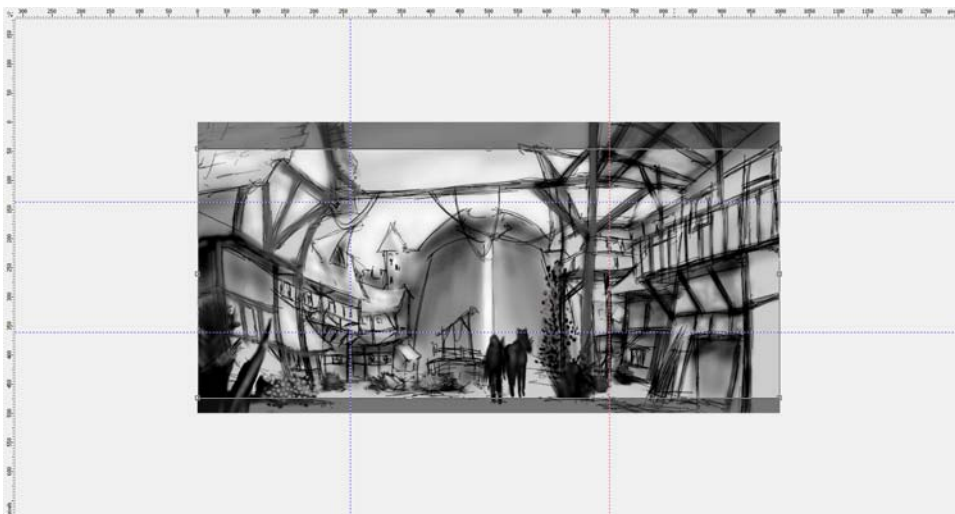

Figure 3: Guidelines are dragged from the rulers.

Defining composition, dimensions, and point of view

When I find a satisfying idea to represent the subject, I need to make decisions about composition, cropping, and point of view.

I decide to use a chiaroscuro with a dark foreground, bright center, and dark background. A crop in panoramic format — for example 21:9 — would fit well with the entire composition.

To fit the image to the desired dimensions, I use the **Crop** tool. The cutoff area appears as a dark gray shade, so I can see the resulting ratio before I actually crop the image.

I use the golden ratio to arrange the main areas of focus in the image. In addition, I use guidelines to set up the main elements of the composition. To use the guidelines, I must first activate the rulers by pressing **Ctrl + Shift + R**. Now that the rulers frame my active workspace, I can pull down guidelines by dragging them from the rulers (Figure 3).

Setting up texture brushes

Next, I prepare custom brushes with textured nibs, which will add texture to the image as I paint. I refer to these custom brushes as “texture brushes.” In one stroke, a texture brush can generate complicated objects (such as leaves) or simulate natural textures (such as rock or bark).

I set up a brush from the **Art brush** category and apply a nib from a customized nib library. I customize my nib libraries and save them separately to load only the nibs that I use (Figure 4). For example, one library contains nibs with bark textures, and another library contains nibs with stone and rock textures. I can preview the nibs of the current nib library in the **Brush settings** docker (Figure 5).

Although you can use the same nib on different brushes, I prefer to set up the same brush with different nibs and then save each combination of brush and nib as a separate preset. This method saves me time later when I elaborate on the image details.

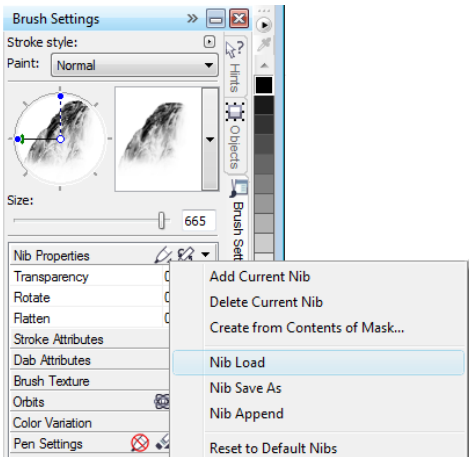

Figure 4: Loading a nib library

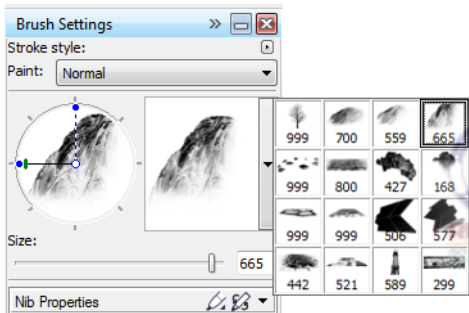

Figure 5: Previewing nibs in the current nib library

Creating brush nibs from mask content

Corel PHOTO-PAINT offers a convenient way to create nibs from any image you like. You can simply use the image as a mask on a black background and create a nib from the mask content. I choose the image of a rock, which I will use for a stone texture nib. First, I apply a black background to bring out the necessary texture for the nib, and then I add a vignette effect to the edges (Figure 6). The mask will be loaded as a grayscale image with values between black (masked areas) and white (editable areas).

I create a new document with a black background, and with width and height set at 999 pixels. These dimensions are the largest at which a brush nib can be saved.

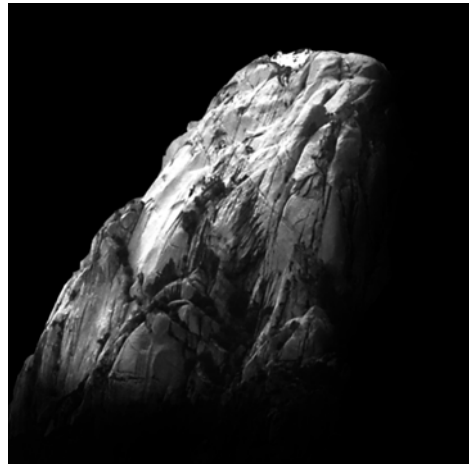

Figure 6: The image of a rock will be used as mask. A black background and a vignette effect are added.

I then load the image of the rock as a mask (**Mask ▶ Load ▶ Load from disk**). The mask overlay must be turned on to make the mask visible and to set the mask content as a nib (Figure 7).

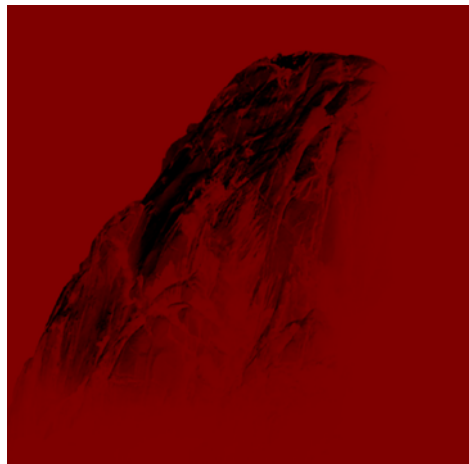

Figure 7: The image of the rock is loaded as a mask. The mask overlay covers the protected areas.

Now the dark areas are masked, and the bright areas appear dark. The unmasked areas will later act as a “stamp” in the texture brush, when the nib is created from the mask content.

In the **Brush settings** docker, I click the **Nib options** icon and choose **Create from contents of mask** (Figure 8). Finally, I save the brush as a preset (Figure 9).

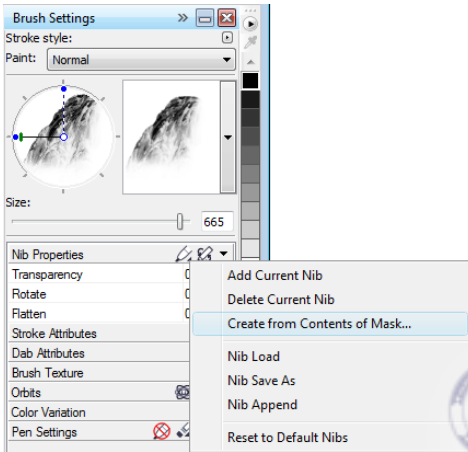

Figure 8: Creating a brush nib from the mask

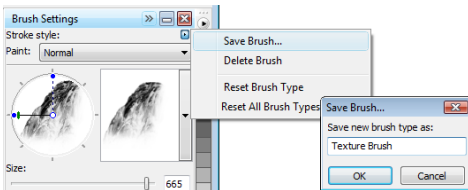

Figure 9: Saving the brush as a new preset

The nib is ready. For my composition, I will create more nibs so that I have a choice of textures.

Adding colors

Now it's time to start painting. I create a new document with a width of 2100 pixels and a height of 900 pixels. For the background, I choose a neutral earthy color, such as ocher.

One of my sketches will be used as an overlay, so I import it as a new object and resize it to match the document size. I set the merge mode in the **Objects** docker to **Multiply** so that I can see only the dark values of the pencil strokes. In **Normal** mode, the sketch would not be transparent at all.

Before I begin painting, I create a palette with sample color patches. Later, I'll extract colors from this palette and add them to the **Image** palette, which provides a single location for storing all the custom colors that are used in an image. The **Image** palette is displayed by default, but if hidden, it can be accessed by clicking **Window > Color palettes > Image palette**. First, I click the flyout arrow on the **Image** palette and disable the **Automatically update** option to prevent new colors in the image from being automatically added to the **Image** palette. By disabling this option, I can control which colors are added to the palette.

Next, I create a new object named **Palette**. With a brush from the **Art brush** category, I paint some patches in different color variations on a muddy light-brown background (Figure 10). The palette consists of some cold and warm colors with different hue and saturation values. It is essential to balance and harmonize the colors.



Figure 10: Sample colors are painted on a separate object.

Then, I hide all other objects in the **Objects** docker so that my **Palette** object is the only visible object. I click the flyout arrow on the **Image** palette, and I choose **Add colors from visible** to add the colors of my painted sample to the **Image** palette (Figure 11). Next, I make the other objects visible again and hide the **Palette** object. When I paint, I use colors from the **Image** palette because it contains only the colors I want for this image. To change a color slightly while painting, I point to the color on the **Image** palette and hold down the mouse button until a pop-up color palette appears. Then, I choose a slightly different color.

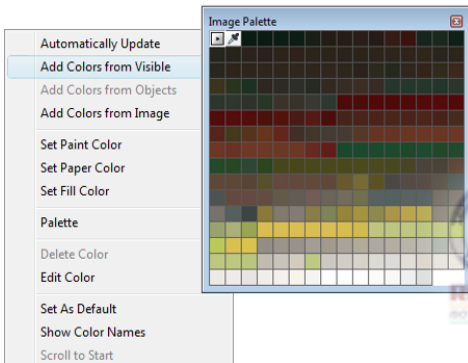

Figure 11: Adding colors to the **Image** palette

I paint at three separate levels: foreground, center, and background. Each level is a separate object (Figure 12), and I create rough and clumsy shapes (Figure 13).

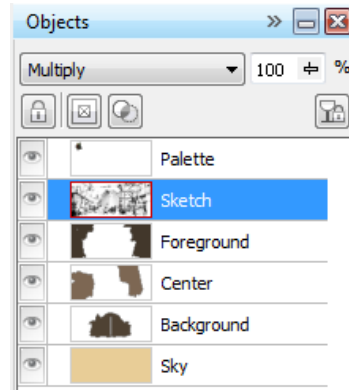

Figure 12: The foreground, center, and background are separate objects.

I erase some parts of the sketch to produce a cleaner impression of shapes. At this time, I focus only on the composition and relevant forms. When I am satisfied with the composition, I will correct the tone and brightness of the foreground, center, and background separately, to adjust the overall impression. Using a brush from the **Airbrush** category, I add initial value differences in lighting.

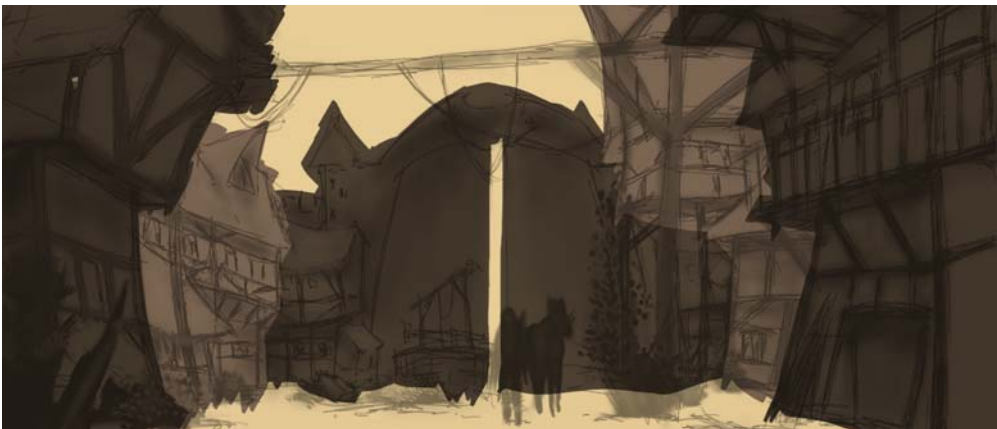

Figure 13: The main shapes are blocked out.

Defining the shapes

Some forms are too rough and require more definition, so I need to subtract detail in some areas. For this task, I avoid using an eraser, because whatever is erased is lost permanently. Instead, I fall back on another mighty feature of Corel PHOTO-PAINT, the clip mask. Instead of erasing parts of objects, you can “paint” them into invisibility by using clip masks.

To generate a new channel on which I can paint the transparency, I select the object and click **Object ▶ Clip mask ▶ Create ▶ From object transparency**. I use black to paint transparent areas, and white to paint opaque areas.

The original object is preserved. Later, I can bring out the invisible parts of the object by painting over the clip mask again without losing the original object. Another advantage of using clip masks is that I can create a separate clip mask for each object (Figure 14).

I work out the shapes with a flat brush. To create this brush, I assign a high **Flatten** value to a custom brush from the **Art brush**

category. I use this flat brush for blocking out the main shapes (Figure 15).

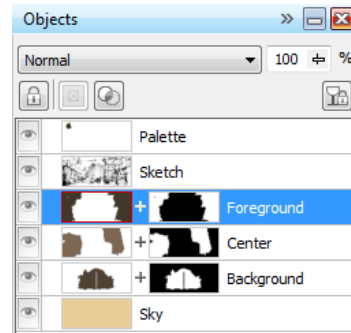

Figure 14: Clip masks are listed in the **Objects** docker. A red outline indicates the active clip mask.

Adding texture and details

It’s time to add the first textures. At this point, I merge all objects with the background (**Ctrl + Shift + Down arrow**) so that I can blend the colors. Different texture brushes help me further define the structure of the houses and the vegetation.

I work strictly from dark to bright, because areas in the shadows need fewer details than the more visible, brighter areas. I always follow the rule to paint only what is visible.



Figure 15: A flat brush is used to define the main shapes.

In the **Brush settings** docker, I have set the **Fade out**, **Edge texture**, and **Bleed** values of my brush between 30 and 40. I use this custom brush as a kind of oil brush to “mold” the plasticity of the forms. With the **Pencil** brush, I define the highlights and textures a bit more (Figure 16).

To define the distance effect, depth, and distance blur, I gently brighten more distant areas with a custom brush from the **Airbrush**

category. This brush helps me generate an atmospheric haze. You might notice that the more distant areas have less detail than the areas in the foreground. This arrangement of detail lets me pull the visual focus to the center. Areas in the shadows are similarly treated and have less detail as well.

At this point, I add some more details and props to the center (Figure 17).



Figure 16: Highlights and textures are defined.



Figure 17: More details are added to the image.

Making color corrections

When unsaturated colors are used, faded colors always shift on the color wheel. If you try to lighten red by adding white or a bright gray, the color moves on the color wheel toward the cooler colors. Also, the brightness and contrast change when you apply pale colors to underlying tones. To gain control of these color shifts, I first use my custom brush from the **Airbrush** category in **Color** or **Overlay** merge mode. These merge modes help me fit colors to each other by balancing color and brightness values.

The last step is to adjust the global color by using the tone curve (**Ctrl + T**). I reemphasize contrasting colors and fit harmonizing colors to each other. I correct the color and tone by adjusting a single channel, called the composite channel, in which all channels of the image are combined (Figure 18). The graph represents the balance between shadows (bottom of graph), midtones (middle of graph), and highlights (top of graph).

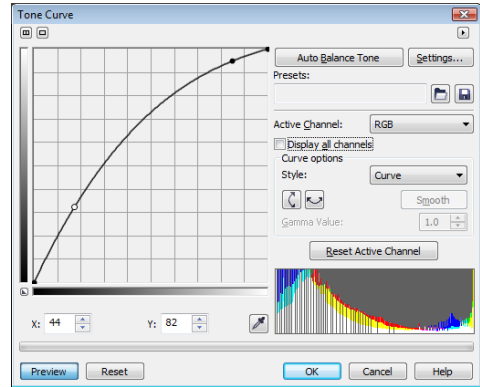

Figure 18: The tone curve allows adjustment of color and tone.

The slightly warped houses bring out the droll charm of the town, while the peeling paint of the storefronts underlines aging and desolation. An earthy color palette with pale colors, and props such as the lost wheel and sprawling vegetation, convey an abandoned but welcoming atmosphere (Figure 19). My intention was to avoid cold colors, which would have lent a hostile flavor to the image.



Figure 19: The color and tone are adjusted to convey the right atmosphere.

Preparing the image for the Web

I intend to send the finished artwork to the client by e-mail, so I need a high-quality image with a small file size. To optimize the image for the Web, I click **File ▶ Export for Web** (Figure 20). I choose **JPEG** from the **Format** list box and adjust the JPEG settings. I keep the color mode as **RGB Color (24-bit)**, because the artwork will be displayed on-screen. Next, I set the **Quality** control to **100** to prevent JPEG artifacts, which appear at high compression rates. I set the **Sub-format** control to **Optional (4:4:4)**, which improves the sampling rate of colors and prevents more saturated colors from bleeding. I also set the **Blur** control to **0** so that the image maintains its original sharpness.

In the **Advanced** area, I make sure that the **Anti-aliased** box is checked for a clean look,

and I use the document color settings instead of the color proof settings. I do not embed the color profile, but I check the **Optimize** box for best compression. I do not pay much attention to the **Transformation** area, because I want to maintain the original image size and resolution. When I am satisfied with the settings, I save the image.

I send the final concept image to my client, the art director. Usually, I create three or four different concept images and then elaborate on the one chosen by the art director so that it matches the visual style of the game. Detailed drawings of the architecture and arrangement of the houses will follow. The final concepts will be modeled by 3D artists in 3D applications to create a virtual-adventure game world. There, behind a picturesque facade, you'll discover hazards that lurk among the shadows of an old and abandoned town.

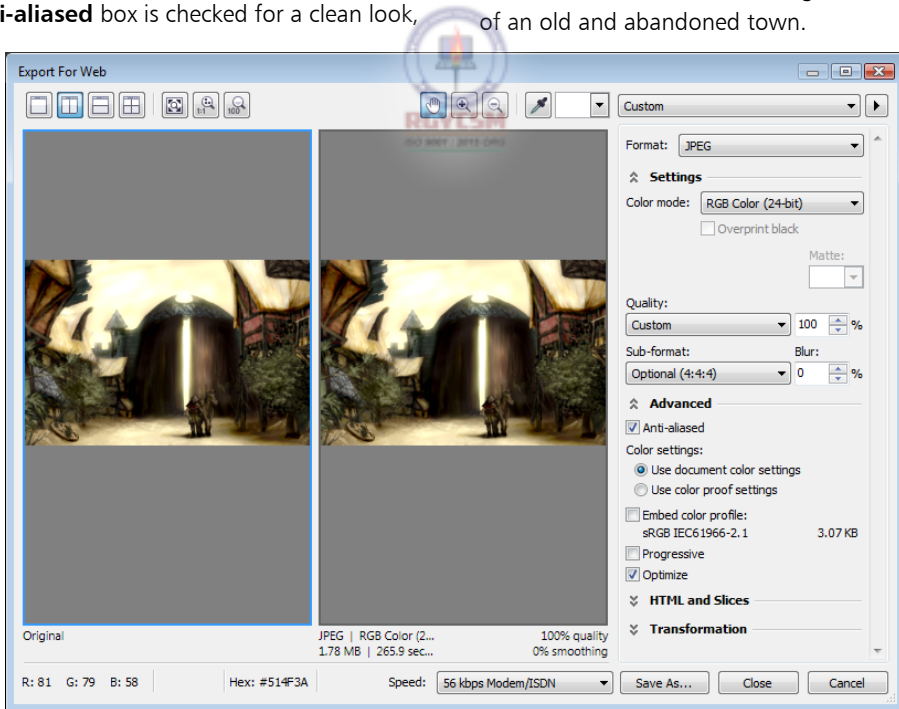

Figure 20: The **Export for Web** dialog box allows a side-by-side comparison of the Corel PHOTO-PAINT file and a preview of the output.



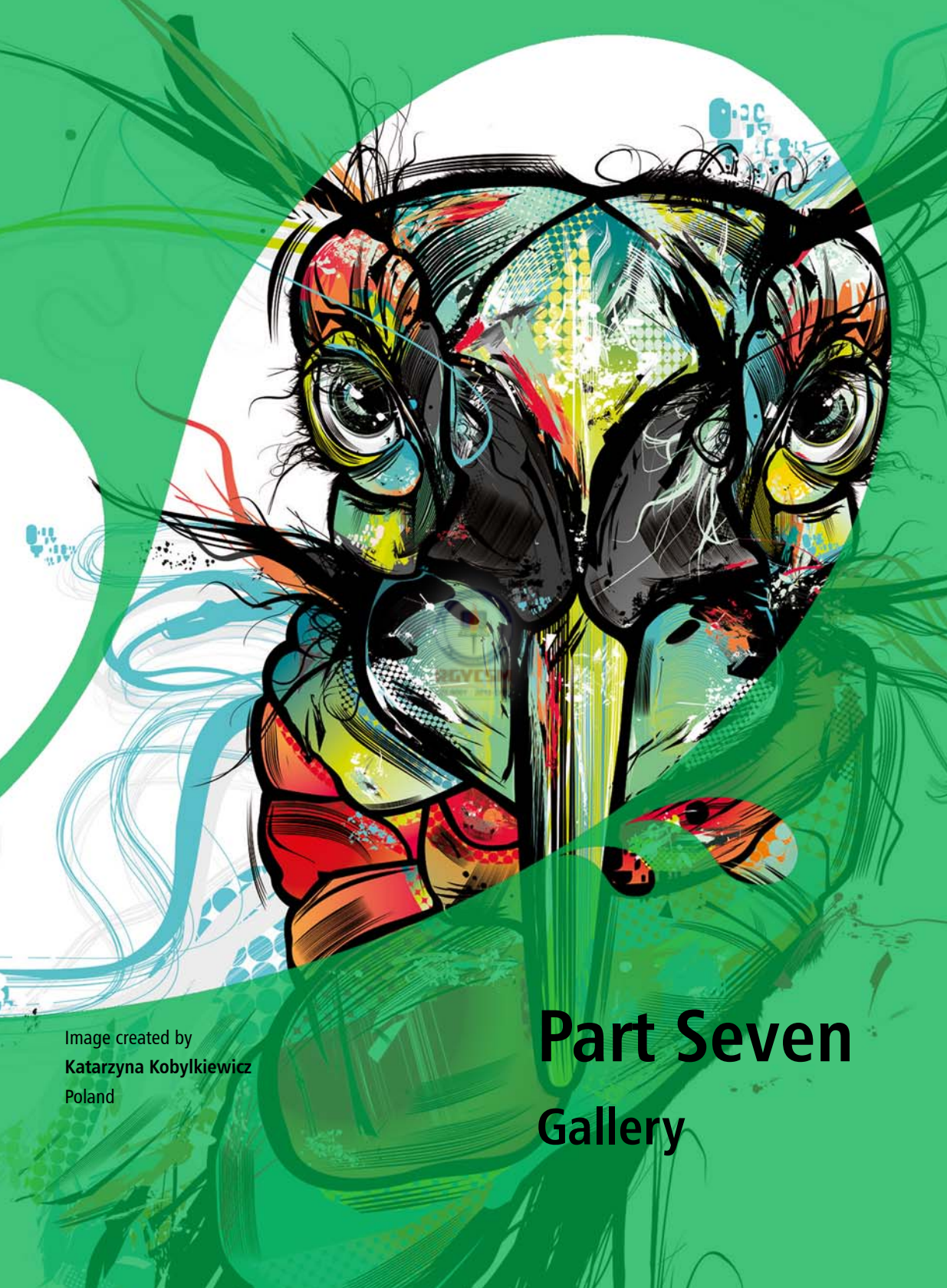

Image created by
Katarzyna Kobylikiewicz
Poland

Part Seven Gallery





Michél Nettling



Галия Югай Galia Yugai

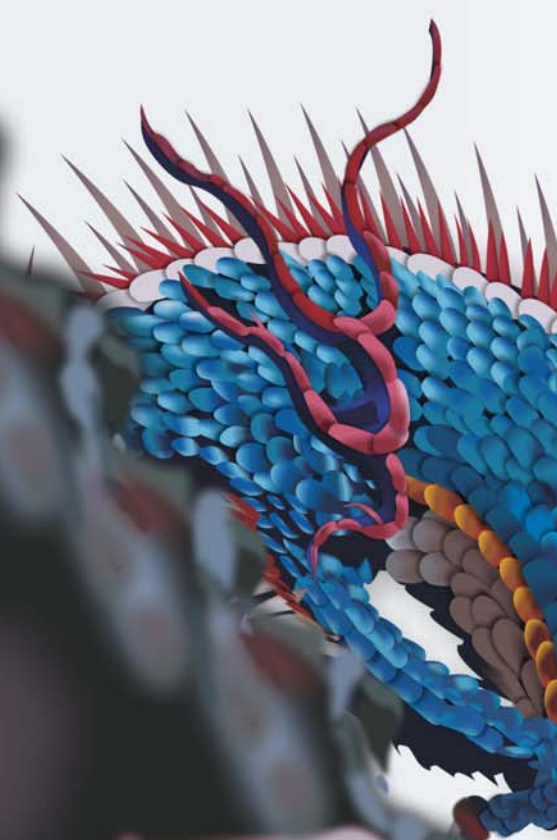











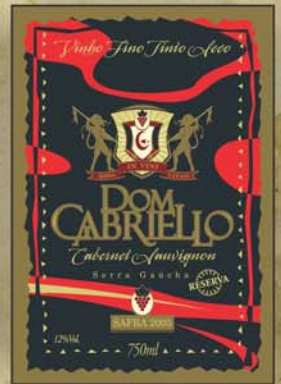
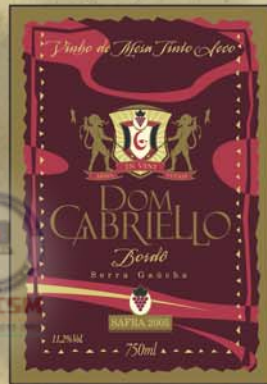
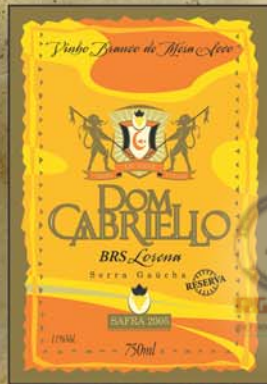
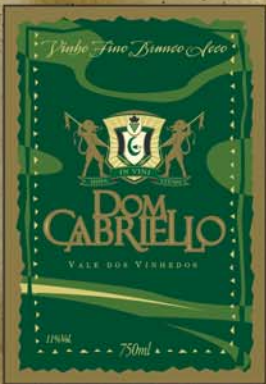
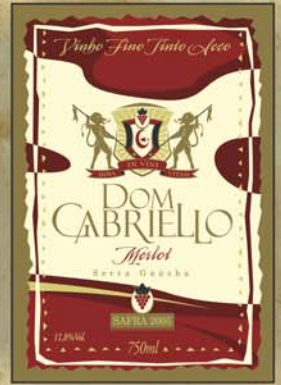
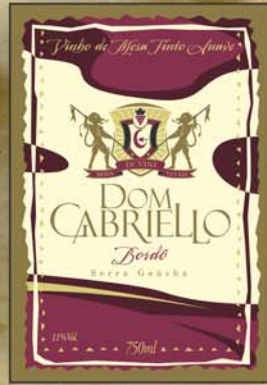
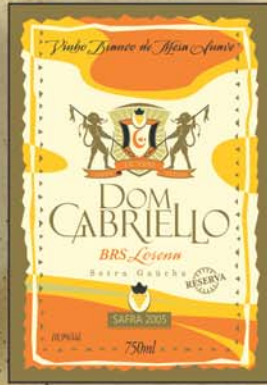
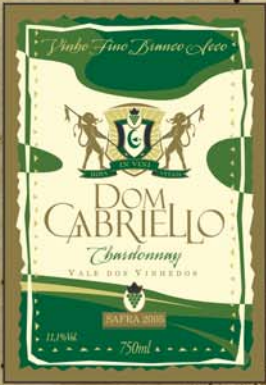





Manoj Ashok R





Fabio Syelani





Aleksey Oglushevich
Алексей Оглушевич





RA-L-AGNA
BY ICRALSAID

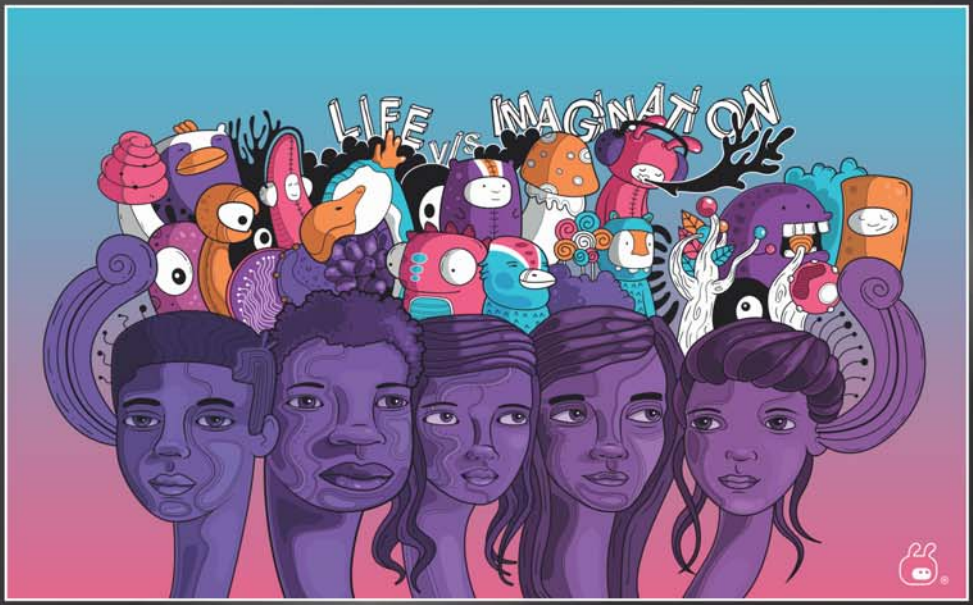

Giulia Marchetti Hennings

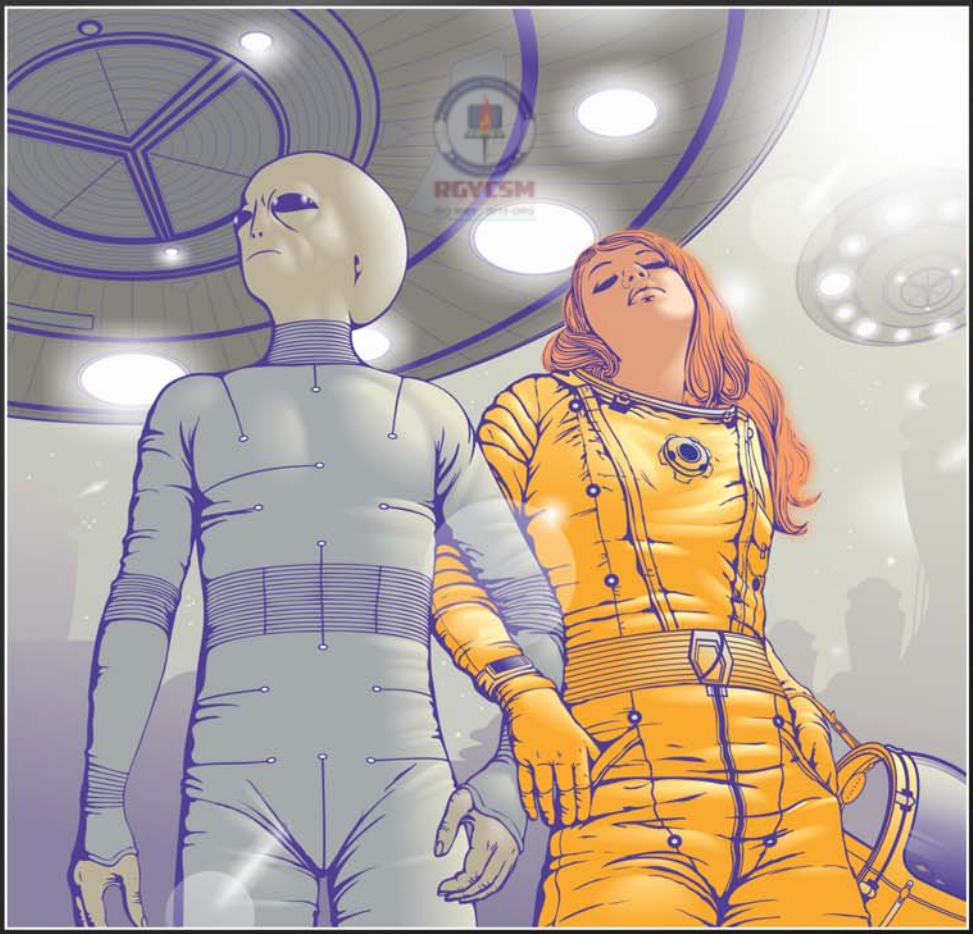

RAMM ND

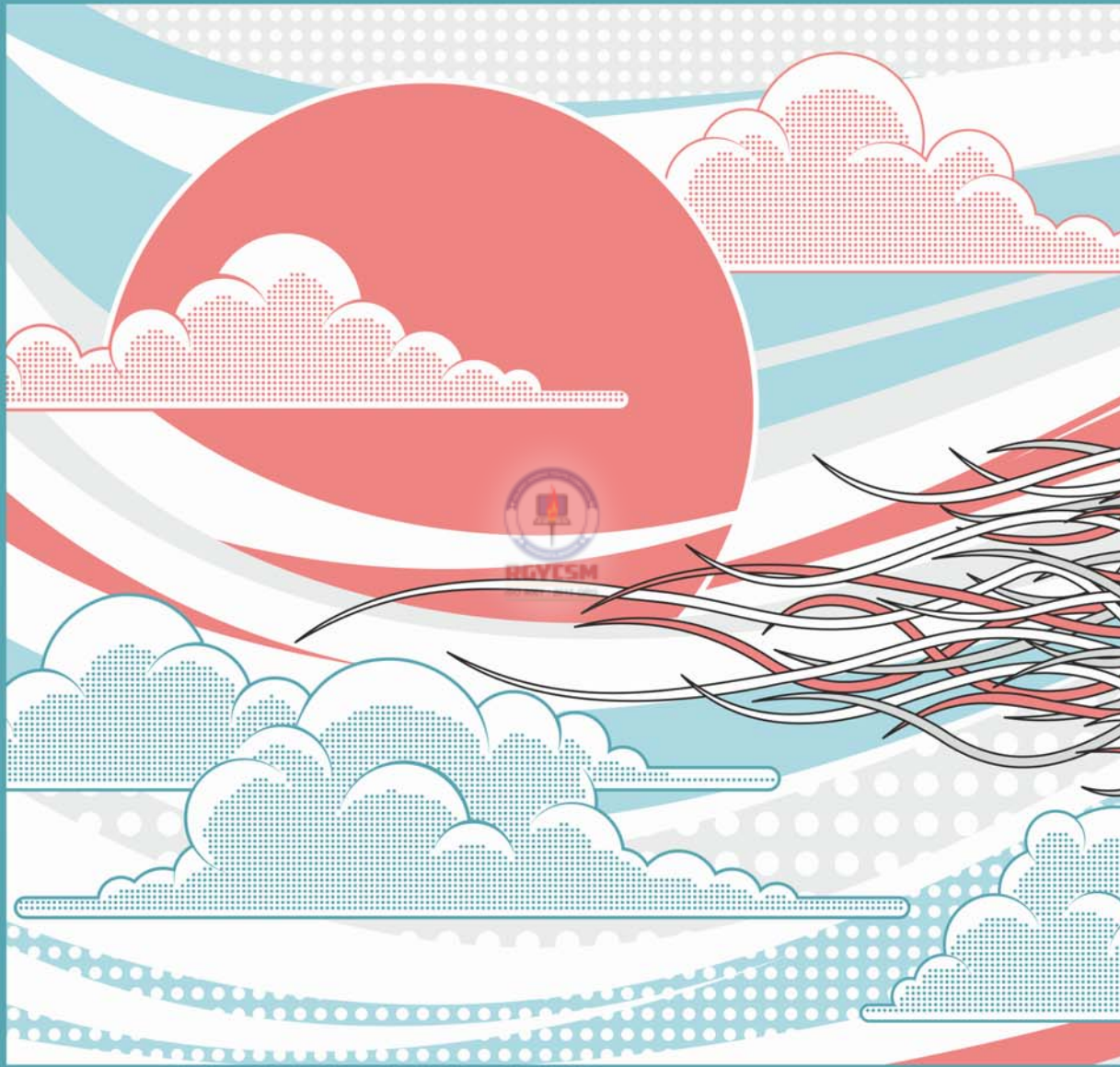

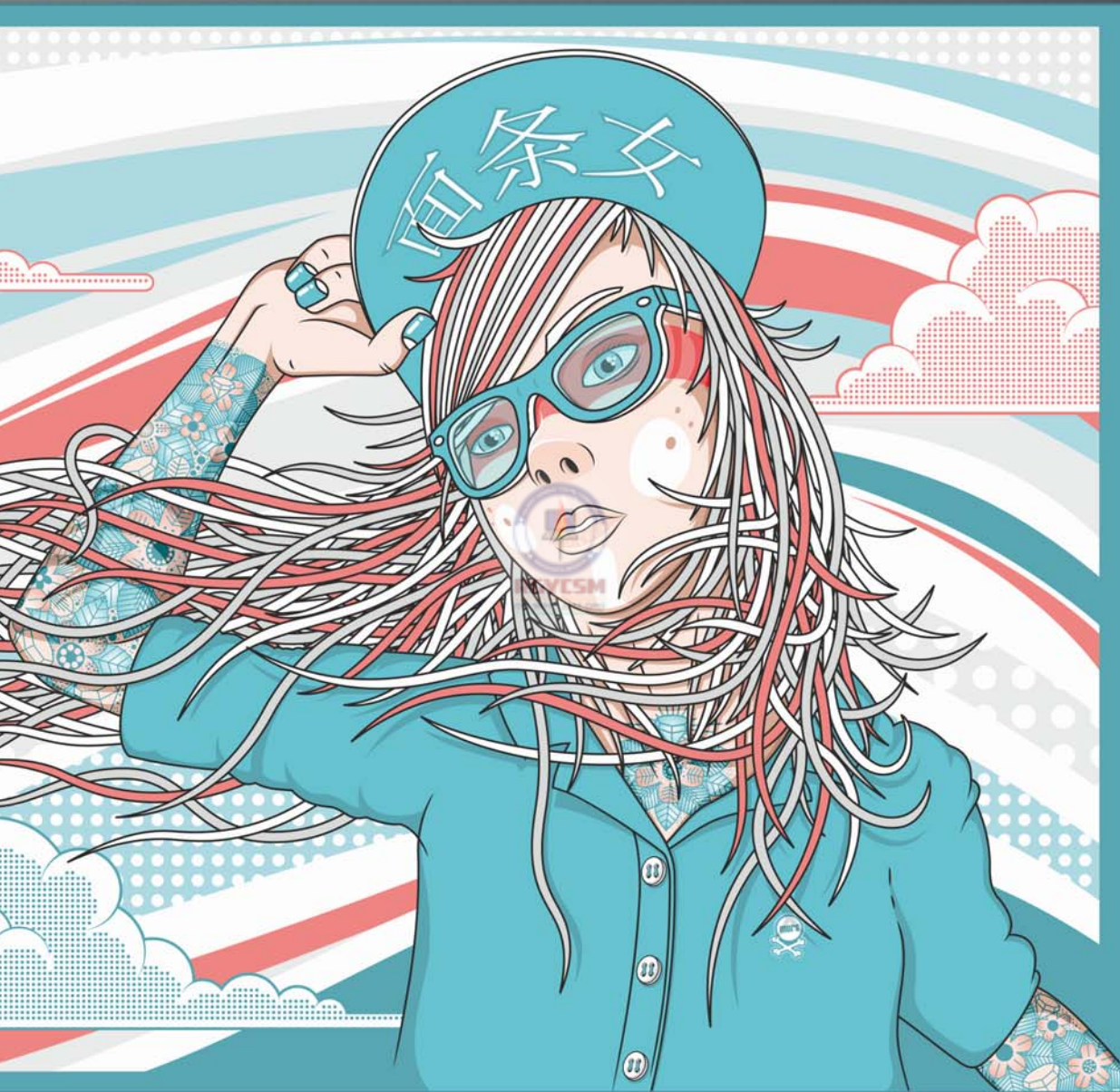





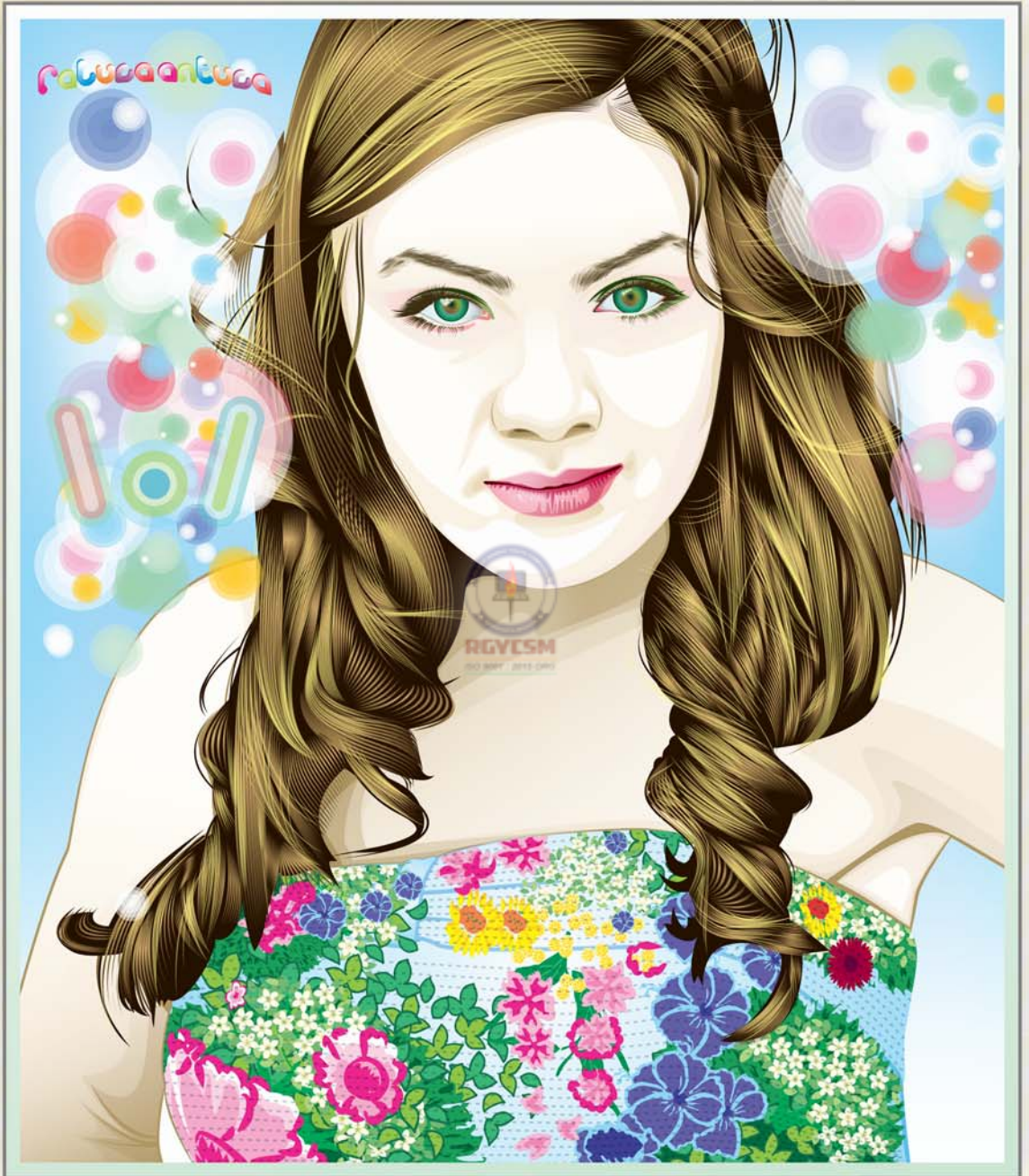

Wino Skadir

2.011
Kick my Art



Nur Hidayat Hyda

Fabiana Henkemaier de Souza



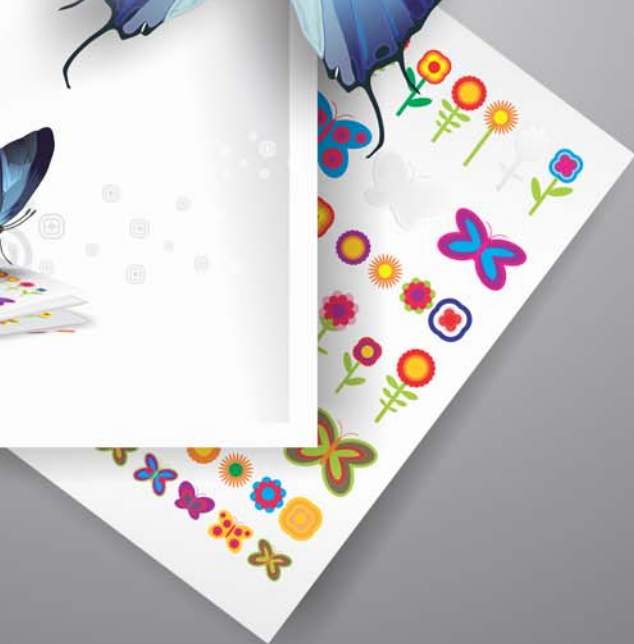





TechBikeKIDS
Pedale com Tecnologia

Saúde

Beleza

Design

Conforto

Natureza

Inovação

Esporte

Lazer

Prática

super TechBike

Pedale com Tecnologia



TechBikeKIDS
Pedale com Tecnologia

super TechBike

Pedale com Tecnologia



Contem uma bicicleta modelo 0134

Indicada para crianças a partir de 10 anos



Prática

Lazer

Esporte

Inovação

Natureza

Conforto

Design

Saúde

Beleza



Modelo 0134 - Tamanho 1 - Capacidade Carga 20kg - Peso Líquido 12,5kg

Indicada para crianças a partir de 10 anos

Contem uma bicicleta modelo 0134

Indicada para crianças a partir de 10 anos

Contem uma bicicleta modelo 0134

Indicada para crianças a partir de 10 anos

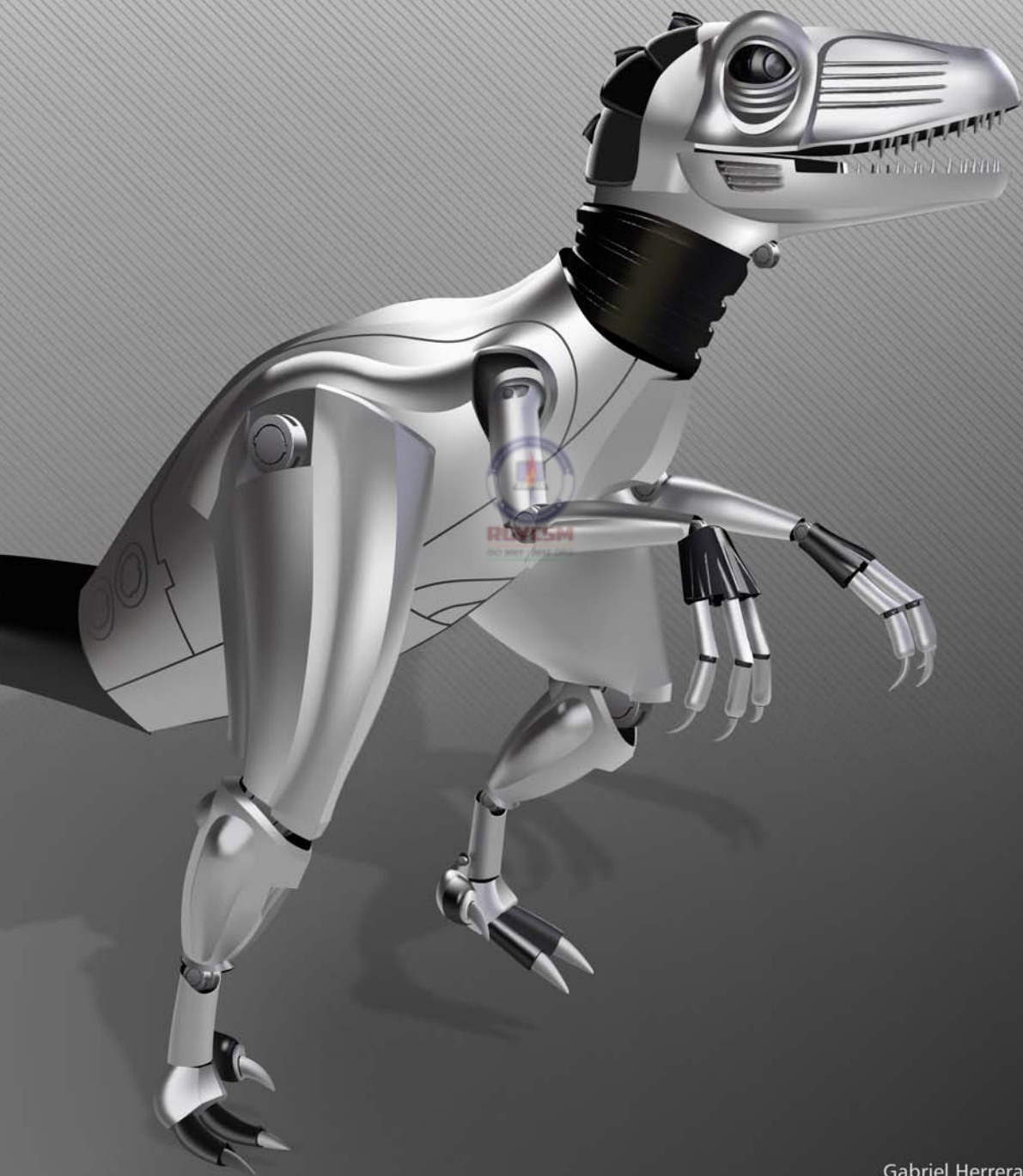

Алексей Оглушевич
Aleksey Oglushevich



Agustina Volpellier



Subhash









Nataliya Trush





Index

Numerics

64-bit support 19

A

Absolute Colorimetric rendering intent 93

acquiring images 57
hand-drawn concepts 169

aligning
objects 173
text 112

alignment guides 206

application window
Corel PHOTO-PAINT 48
CorelDRAW 28

applications
changing languages 12
included 4
installing 12
technical support 13
updating 12

Arrow Shapes tool 35
using 213

arrow shapes, drawing 213

artistic media included 150
samples of 151, 155

Artistic Media tool 35
Brush mode 185

Calligraphic mode 186
Preset mode 185
presets included for 150
Pressure mode 187
Sprayer mode 186

artistic text 36
adding 106, 207

Asian text spacing 111

B

Background Color swatch 56

backgrounds, page 44

backing up documents 46

Banner Shapes tool
using 213

banner shapes, drawing 213

baseline grid 210

baseline grid, aligning text to 112

Basic Shapes tool 34
using 213

basic shapes, drawing 213

Bevel effect, using 174

bevels 41
adding 174

Bézier tool, using 189

bitmap fills, applying 148



- bitmaps, in documents** 36
 - editing 37
 - inserting 37
 - tracing 187
 - using Shape tool on 213

- Bitstream Font Navigator** 4
 - starting 136

- bleed** 247

- Blend tool, using** 214

- blending objects** 214

- booklet design** 231, 246

- borders** 170

- Boundary command, creating borders** 171

- brochures (examples)** 160

- browsing content** 132

- Brush Mask tool** 51

- Brush Settings docker** 187

- Brush tool** 35
 - using 185

- Brush tools (category)** 54

- brushes**
 - creating nibs from masks 255
 - customizing 187
 - customizing texture nibs 254

- brushes included** 152
 - samples of 153

- brushstrokes**
 - creating objects from 65
 - drawing with 184

- bulleted lists, inserting** 114

C

- calibrating monitors** 92

- Calligraphic tool** 35
 - using 186

- Callout Shapes tool**
 - using 213

- callout shapes, drawing** 213

- chamfers** 41

- character spacing** 110

- characters, formatting** 107

- circles, drawing** 188

- clip masks** 18, 258

- clipart included** 140
 - browsing and searching 132
 - samples of 141



- Clone tool** 53

- cloning image areas** 61

- CMYK color model** 73
 - best practices for 103

- Collect for Output wizard**
 - using 217

- Color Control area** 56

- color editor, using** 81

- Color Eyedropper tool** 41
 - using 80

- color harmonies**
 - creating 82
 - editing 82
 - working with 81

- color management** 89
 - best practices for CMYK 103
 - best practices for Web 103
 - getting started 91
 - importing and pasting with 102
 - opening documents with 101
 - policies for 100
 - printing with 102
 - settings for 94
 - understanding 90

- color models** 72

- color modes** 60
 - choosing 75

- Color Palette Manager docker**
 - using 86

- color palettes**
 - Corel PHOTO-PAINT 49
 - CorelDRAW 29
 - customizing 88
 - displaying 86
 - organizing 86
 - using 77

- color profiles**
 - assigning 97
 - best practices for 92
 - converting colors 98
 - embedding 98
 - installing and loading 97
 - working with 97

- Color Proof Settings docker** 98
 - using 177

- color proofing, understanding** 98

- color styles**
 - working with 79, 81

- Color styles docker, using** 79

- Color styles palette, using** 84

- Color Transparency tool** 55

- colors** 71
 - adding to images 256
 - adding to palettes 84
 - adjusting in images 62
 - applying with palettes 191
 - choosing 77
 - converting 98
 - correcting 260
 - creating transitions 175
 - matching 89
 - proofing 98
 - proofing, for signs 177
 - reproducing 89
 - reusing 41
 - understanding 72



- columns**
 - in booklet design 231

- columns, inserting** 115

- combining objects** 43

- concept art (tutorial)** 251

- concepts, hand-drawn**
 - scanning 169

- ConceptShare** 66
 - using 217

- connector lines** 32

- Connector tools (category)** 32

- content** 16
 - finding and managing 129
 - types of 135

- using 134
- using in signs 172
- Contour tool, using** 173
- contours** 41
 - adding 173
 - creating for logos 228
- converting images** 60
- converting shapes to curves** 188
- Corel CONNECT, using** 129
- Corel Content** 17
- Corel Corporation** 13
- Corel PHOTO-PAINT basics** 47
- Corel PowerTRACE, using** 187
- Corel Support Services** 13
- Corel Technology Partners** 9
- Corel Training Partners** 9
- CorelDRAW basics** 27
- correcting colors** 260
- Crop tool** 51
- cropping images** 57
- Cropping tools (category)** 32
- Curve tools (category)** 31
- curves** 35
 - closing 190
 - converting shapes to 188
 - drawing 189
 - shaping 190
- custom palettes, creating** 88

D

- deployment guide** 8
- dimension lines** 32
 - in production drawings 249
- Dimension tools (category)** 32
- distorting objects** 195
- distributing objects** 173
- dockers**
 - Corel PHOTO-PAINT 49
 - CorelDRAW 29
- document navigator** 29
- document pages** 29
 - backgrounds 44
 - sizing 44
 - using 44
- Document palette**
 - adding colors to 84
 - applying colors with 191
 - using 84
- document window** 29
- documents, CorelDRAW**
 - backing up 46
 - choosing color modes 75
 - color settings for 96
 - creating from templates 158
 - displaying fonts used 136
 - exporting 45
 - laying out pages 199
 - modifying template-based 160
 - navigating 34
 - opening with color management 101
 - printing 45
 - saving as templates 162



- scaling, for signs 169
- setting up 33
- setting up, for illustrations 183
- setting up, for page layouts 201
- setting up, for signs 169
- sharing 44

drawing

- basic shapes 213
- brushstrokes 184
- curves 35
- lines 35
- objects 187
- shapes, in documents 34

drop caps, inserting 113

Drop Shadow tool 55

- using 174

drop shadows 41

- adding 174

duplicating objects 42

dust, removing 61

dynamic guides 43

E

editable areas, creating objects from 65

Effect tool 54

effects, object 40

- applying 194

Ellipse Mask tool 50

Ellipse tool

- Corel PHOTO-PAINT 53
- CorelDRAW 34
- using 188

ellipses, drawing 188

embedding color profiles 98

Envelope tool

- modifying borders with 171
- using 195

Eraser tool 52

- using 175

erasing text 175

Erasing tools (category) 32

ergonomic principles 238

examples, project

- brochures 160
- illustrations 196
- page layouts 217
- signs 179

exporting

- documents 45
- images 66
- PDF files 216
- PDF files, signs 177



extra content 135

extrusions 41

Eyedropper tool 52

- using 80

F

fabricating signs 178

fading objects 194

features, new 15

file formats, for images 66

files

- color management of 102
- exporting to PDF 216
- importing 212
- preparing for output 215
- saving as PDF 216

Fill Color swatch 56

Fill tool 54

Fill tools (category)

- Corel PHOTO-PAINT 54

- CorelDRAW 31

fills

- creating shapes from 227

fills, object 39

fills, uniform fill 80

finding content 129

fitting text to paths 211

flow lines 32

Flowchart Shapes tool 35

- using 213

flowchart shapes, drawing 213

flyouts

- Corel PHOTO-PAINT 49

- CorelDRAW 29

fonts 136

- browsing and searching 132

- identifying 172

- previewing available 136

fonts included

- samples of 137

Foreground Color swatch 56

formatting text 107

Fountain Fill tool 40

fountain fills

- adding with Interactive Fill tool 214

frames, text

- creating 208

- linking 209

Freehand Mask tool 50

Freehand tool 35

- using 189

furniture design (tutorial) 235

G

getting started

- Corel PHOTO-PAINT 47

- CorelDRAW 27

GIF file format 66

gradients, creating 83

Graph Paper tool 34

graphics, for page layouts 212

grayscale color model 74

grid 43

grouping objects 43

guidebook 4

- conventions of 5

guidelines

- using 204

- using presets 205

guides, dynamic 43



H

hand-drawn concepts

scanning 169

harmonies

color 81

creating 82

editing 82

Help feature 6

Hints feature 6

HSB color model 74

I

illustrations 181

examples of 196

Image Adjustment Lab

using 176

image areas

cloning 61

masking 64

Image palette

adding colors to 84

adding colors with 256

applying colors with 191

using 84

Image Slicing tool 56

Image Sprayer tool 54

image window 49

images, Corel PHOTO-PAINT

adding texture and detail 258

adjusting 176

adjusting color and tone 62

applying special effects 196

choosing color modes 76

correcting colors 260

cropping 57

defining composition 254

masking in 64

preparing for Web 261

printing 66

publishing to ConceptShare 66

publishing to PDF 66

reducing size 59

rotating 57

setting up, for illustrations 183

sharing 66

sizing and resampling 58

importing

files 212

files, managing colors when 102

photos 57

text 107



installing

color profiles 97

software 12

Interactive Fill tool

adding fountain fills with 214

Corel PHOTO-PAINT 54

CorelDRAW 40

creating color transitions with 175

using 175

interactive frames, samples of 147

Interactive OpenType 109

Interactive tools (category)

Corel PHOTO-PAINT 55

CorelDRAW 31

J

JPEG file format 66

K

kerning text 110

L

Lab color model 72

language spacing 111

languages, changing 12

Lasso Mask tool 50

Latin text spacing 111

layers

even-page master layers 203

master layers 202

odd-page master layers 203

laying out pages 199

layout

in booklet design 231, 246

Layout toolbar 207

learning resources 6

legacy text, updating 116

lenses 65

line spacing 111

Line tool 53

lines

drawing 189

shaping 190

loading color profiles 97

logos

creating 221

creating style guide 230

digitalizing 227

establishing client needs 223

researching 224

sketching 226

M

macro programming guide 8

Magic Wand Mask tool 51

Magnetic Mask tool 51

Mask tools (category) 50

Mask Transform tool 50

masks

creating brushes from 255

master page 202



matching colors 89

measurement units, setting 46

menu bar

Corel PHOTO-PAINT 49

CorelDRAW 29

Mesh Fill tool 40

using 192

Middle Eastern text spacing 111

mirroring objects 38

moiré, removing 62

monitors, calibrating 92

My Palettes folder, using 87

N

navigating documents 34

Navigator pop-up 49

network deployment guide 8

new features 15

nodes

adding and deleting 189

shaping 190

noise, removing 61

nudging objects 46

O

Object Manager docker 43

managing master pages with 202

Object Pick tool 50

Object Properties docker 17

Object properties docker, using 79

Object Styles docker 119

Object Transparency Brush tool 55

Object Transparency tool 55

using 194

objects

breaking link to styles and style sets 124

finding objects using a specific style 124

using styles and style sets 118

Objects docker

using 176

objects, document 34

adding bevels 174

adding contours 173

adding drop shadows 174

adding effects 40

adding perspective 195

adding transparencies 40

aligning and distributing 173

blending 214

color transitions 175

coloring and styling 38

converting to text frames 106

distorting 195

drawing 187

duplicating 42

filling 39

formatting outlines 39

grouping and combining 43

manipulating 37

mirroring 38

nudging 46

organizing 43

positioning 42

reusing properties 41

rotating 38

sizing 38

skewing 38

snapping 42

stretching 38

transforming 190

objects, image 65

adding drop shadows 174

adjusting opacity 176

aligning and distributing 173

color transitions 175

drawing 187

transforming 190

online content 17

opacity, object 176



OpenType

- accessing features 109
- fonts 108
- Interactive OpenType 109

organizing objects 43

outlines, object 39

out-of-gamut colors, handling 93

outputting files 215

P

page layout

- in booklet design 231, 246

page layouts 199

- examples of 217

page numbers 203

pages, document 29

- backgrounds 44
- laying out 199
- sizing 44
- using 44

Paint tool 54

- presets included for 152
- sketching with 184

Palette Libraries folder, using 87

palettes, color

- Corel PHOTO-PAINT 49
- CorelDRAW 29

Pan tool 52

panning, in documents 34

paragraph spacing 111

paragraph text 36

adding 106

adding frames 208

drop caps 113

in text frames 114

linking frames 209

Pass Through merge mode 19

pasting files, managing colors when 102

Path tool 53

paths, fitting text to 211

Pattern Fill tool 40

pattern fills, applying 148

pattern transparencies, applying 148

patterns included 148

- samples of 149



PDF

- exporting proofs to 177
- publishing images to 66
- publishing to 216

pen tablets, setting up 183

Pen tool 35

- using 189

Perceptual rendering intent 94

perfect shapes 213

Perspective effect 195

photo frames, samples of 155

photo objects included 144

- browsing and searching 132
- samples of 145

photos included 142

- browsing and searching 132

- samples of 143
- Pick tool** 30
 - using 37
- Pick tools (category)** 50
- placeholder text** 210
 - in booklet design 232
- PNG file format** 66
- policies, color-management** 100
- Polygon tool**
 - Corel PHOTO-PAINT 53
 - CorelDRAW 34
- positioning objects** 42
- PostScript Fill tool** 40
- PowerClip frames** 206
- PowerClip objects** 41
 - trimming bitmaps with 172
- preset templates** 158
- Pressure tool** 35
 - using 187
- previewing print jobs** 45
- print jobs**
 - managing colors 102
 - preparing, for commercial printer 45
 - previewing 45
- print service providers** 45
- printing**
 - documents 45
 - images 66
 - images, file formats for 66
 - setting bleed 247

- signs 178
- process colors, using** 76
- production drawings** 249
- profiles, color**
 - best practices for 92
 - working with 97
- proofs**
 - for colors 98
 - for signs 177
- properties, object** 41
- property bar**
 - Corel PHOTO-PAINT 49
 - CorelDRAW 29

- publishing images**
 - to ConceptShare 66
 - to PDF 66
- publishing to PDF** 216



R

- Rectangle Mask tool** 50
- Rectangle tool**
 - Corel PHOTO-PAINT 53
 - CorelDRAW 34
 - creating borders with 170
 - using 188
- rectangles, drawing** 188
- Red-Eye Removal tool** 52
- red-eye, removing** 61
- Relative Colorimetric rendering intent** 93
- rendering intents, using** 93
- Replace Color Brush tool** 55

Replace wizard, using 215

reproducing colors 89

resampling images 58

Reset Color icon 56

resolution, photo
changing 136, 142

resources, learning 6

retouching photos 60

RGB color model 73

rotating
images 57
objects 38

rounded corners 241

rulers 29
measurement settings 46

S

samples

- brochures 160
- illustrations 196
- included artistic media 151, 155
- included brushes 153
- included clipart 141
- included fonts 137
- included frames 147
- included patterns 149
- included photo frames 155
- included photo objects 145
- included photos 143
- included symbol fonts 139
- page layouts 217
- signs 179

Saturation rendering intent 94

saving files as PDF 216

scaling documents, for signs 169

scanning, hand-drawn concepts 169

scratches, removing 61

scrolling, in documents 34

searching for content 16, 132

segments

- drawing 189
- shaping 190

setting up

- Corel PHOTO-PAINT 67
- CorelDRAW 46
- documents 33
- documents, signs 169
- illustrations 183
- page layouts 201
- software 12



Shape Editing tools (category) 18, 30

Shape tool 190

- editing bitmaps with 213

Shape tools (category)

- Corel PHOTO-PAINT 53
- CorelDRAW 30

shapes

- basic 213
- converting to curves 188
- creating from fills 227
- drawing, in documents 34

sharing

- documents 44
- images 66

signs 167

examples of 179

sizing

- document pages 44
- images 58
- objects 38

sketches 184

- for chair design 237
- for concept art 252
- for logo design 226
- tracing 238

skewing objects 38

Smart Blur filter 62

Smart Carver 17

snapping objects 42

soccer club logo (tutorial) 221

soft proofing, understanding 98

software

- content included 135
- deploying 8
- setting up 12
- technical support 13
- updating 12

spacing

- characters 110
- lines 111
- multilingual text 111
- paragraphs 111
- words 110

special effects, applying 196

Spiral tool 34

spot colors, using 76, 77

Sprayer tool 35

- using 186

squares, drawing 188

standard toolbar

- Corel PHOTO-PAINT 49
- CorelDRAW 29

status bar

- Corel PHOTO-PAINT 49
- CorelDRAW 29

straightening images 58

stretching objects 38

styles

- color 81

styles and style sets 117

- applying 121
- breaking link to objects 124
- creating 120
- editing 122
- exporting 123
- importing 123
- in booklet design 232
- selecting objects using a specific style 124

support services 13

symbol fonts included 138

- browsing and searching 132
- samples of 139

symbols, inserting 138

T

Table tool 33

tables 36



tablets, pen

setting up 183

technical support 13

templates 157

creating 162
modifying 160
using preset 158

text

adding 207
adding bevels 174
adding contours 173
adding drop shadows 174
adding perspective 195
aligning 112
aligning to baseline grid 112
color transitions 175
creating frames 208
creating frames from objects 208
creating in documents 36
erasing 175
fitting to paths 211
formatting 107
importing 107
in Corel PHOTO-PAINT 107
in CorelDRAW 106
inserting placeholder text 210
kerning 110
linking frames 209
spacing 110
text overflow, fixing 115
updating legacy 116
using styles and style sets 118

text frames

converting objects to 106
creating 208
creating from objects 208

inserting columns 115
inserting placeholder text 210
linking 209
modifying 114

Text tool

Corel PHOTO-PAINT 52
CorelDRAW 33
using 207

texture

adding to images 258
creating with brushes 254

Texture Fill tool 40

TIFF file format 66

title bar 29

tone curve 260

tone, image 62

toolbar, standard

Corel PHOTO-PAINT 49
CorelDRAW 29

toolbox

Corel PHOTO-PAINT 49
CorelDRAW 29

tools

Corel PHOTO-PAINT 49
CorelDRAW 29

tooltips 6

Touch-Up Brush tool 53

Touch-Up tools (category) 52

tracing bitmaps 187

training resources 8



transforming objects 190

transitions, color 175

transparencies, object 40
applying 194

Transparency tool
using 194

Transparency tools (category) 55

trays 16

tutorials

concept art 251
furniture design 235
soccer club logo 221
video 7

U

Undo Brush tool 55

uniform fill 80

Uniform Fill tool 40

updating software 12

V

video tutorials 7

W

Web

color management for 103
file formats for images 66
preparing images for 261

Web-based resources 8

Welcome screen 7

WhatTheFont?! 172

word spacing 110

workspace

Corel CONNECT 130
Corel PHOTO-PAINT 48
Corel PHOTO-PAINT, resetting 67
CorelDRAW 28
resetting 12

Z

Zoom tool 51

Zoom tools (category)

Corel PHOTO-PAINT 51
CorelDRAW 33

zooming, in documents 34

